



ZTVB/ZTRB

2- and 3-way control valves, DN25...DN40

The valves in the range ZTVB/ZTRB are used to control heating and cooling in climate, heating and ventilation systems. They are intended to be used together with the RVAZ4 actuators.

The control valves in the ZTVB/ZTRB range are available as 2- and 3-way versions. Body and plug in brass, spindle in stainless steel and O-ring made of EPDM. The valves have linear flow characteristics.

Function

The 2-way valve is closed when the spindle is in its highest position and completely open when the spindle is in its lowest position.

The 3-way valve is closed between port A and port AB (the ports opposite to one another) when the spindle is in its highest position. In this position, the valve is also open between the bottom port B and the common supply port AB. When the spindle is in its lowest position, the 3-way valve is completely open between port A and port AB and consequently closed between the bottom port B and the common port AB.

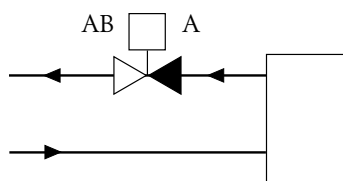

2-way valve

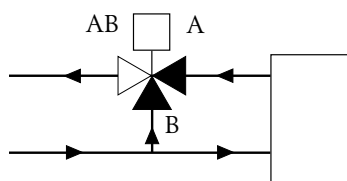

3-way valve

Short facts

- For water and refrigerants (max. 50 % glycol)
- Fluid temperature 1...110°C
- Pressure class PN16
- Rangeability 50:1
- For differential pressure up to 200 kPa
- No leakage when the valve is closed

Installation

The valve is to be mounted with the spindle vertically or 90° to the right or left. It must not be mounted with the spindle pointing downwards. At high media temperatures, the valve is to be mounted with the spindle to the side in order to minimize heating of the valve actuator. For the plug to seal properly, the 2-way valve is to be mounted with the arrow on the valve body pointing in the flow direction.

The 3-way valve is of mixing type and must be mounted in the mixing point, according to the flow direction marks on the valve.

No leakage in closed position

The valve has O-ring sealing between plug and seat, which makes it completely tight in closed position. This makes the valve very energy-efficient.

Typical applications

The valves are used to control hot and cold water in heating, ventilation and climate systems. They can also control refrigerants in for example liquid recovery systems.

Valve actuator

The valves are intended to be used together with the RVAZ4-24A (0...10 V) or RVAZ4-24 / RVAZ4-230 (3-position) actuators.

Models

2-way valves	Connection	Kvs	Max. diff. pressure	3-way valves	Connection	Kvs	Max. diff. pressure
ZTVB25-8	DN25	8	200 kPa	ZTRB25-8	DN25	8	200 kPa
ZTVB32-15	DN32	15	150 kPa	ZTRB32-15	DN32	15	150 kPa
ZTVB40-20	DN40	20	100 kPa	ZTRB40-20	DN40	20	100 kPa

Technical data

Pressure class	PN16 (1.6 MPa)
Connection	Internal pipe thread, see table on page 4
Flow characteristics	Linear
Rangeability	50:1
Stroke	5.5 mm
Leakage control	0 % when the valve is closed
Media	Hot or cold water. Also refrigerants (max. 50 % glycol).
Fluid temperature	1...110°C*

Material

Body	Brass CW614N
Spindle	Stainless steel 1.4305
Plug	Brass CW614N
Seat	Brass CW614N
Packing box	Brass with O-rings made of EPDM.

* The max. temperature is 140°C for the valves and 110°C for the RVAZ4 actuators.

Suitable valve actuators

Valve actuator	Supply voltage	Control signal
RVAZ4-24	24 V AC	3-position
RVAZ4-24A	24 V AC	0...10 V
RVAZ4-230	230 V AC	3-position

Pressure drop diagram

Pressure drop

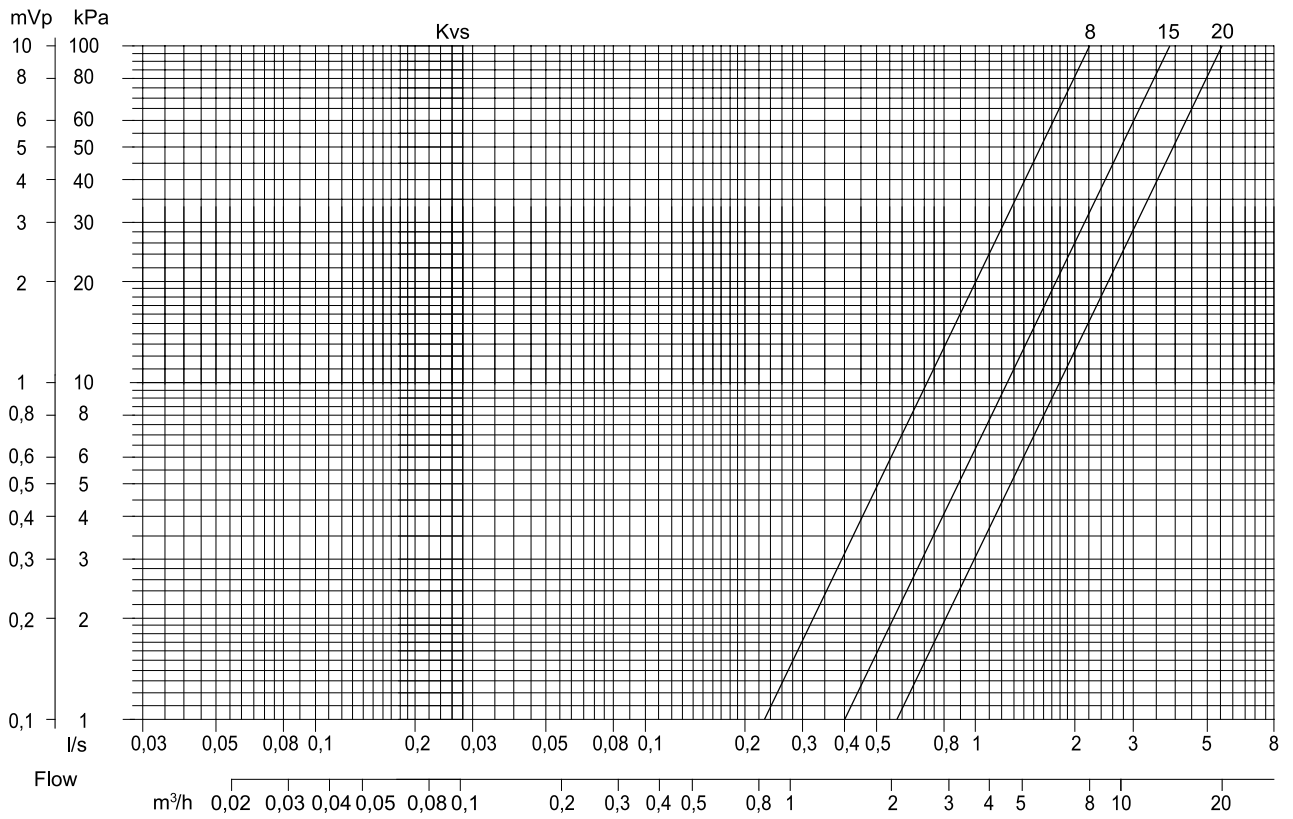

Example: calculation of kv value

If the pressure drop is 13 kPa (A) and the flow is 3 m³/h (B), the kv value is 8 (C).
See the markings in the picture to the right.

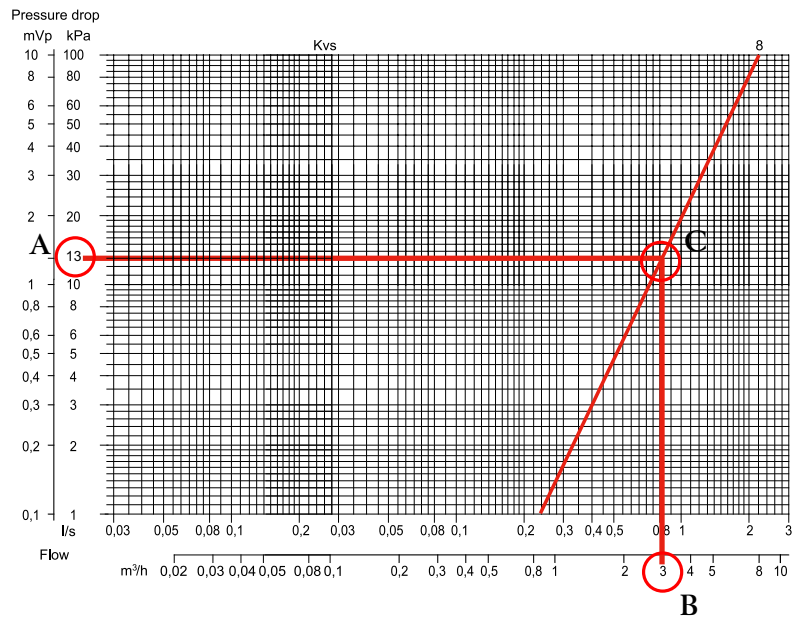

Dimensions

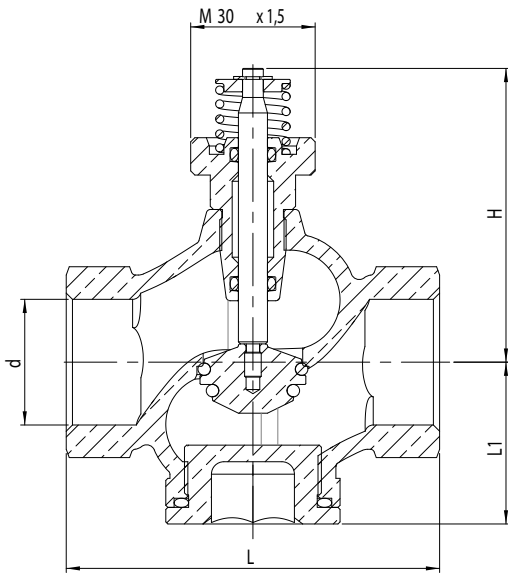

2-way valve, ZTVB

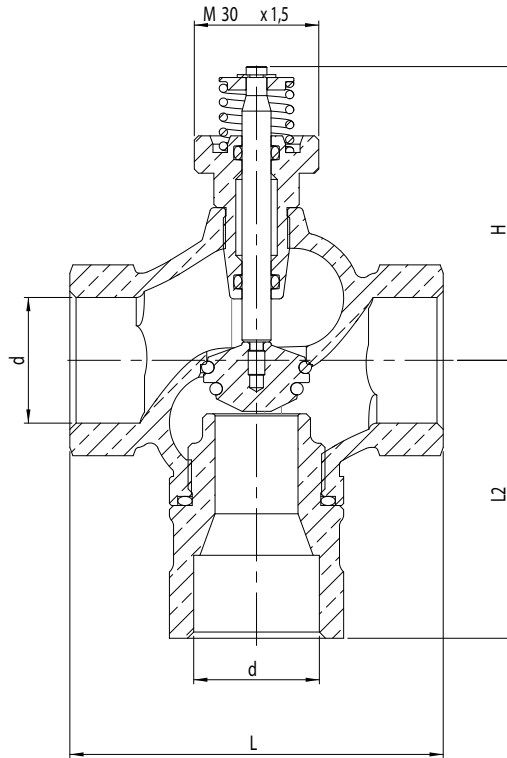

3-way valve, ZTRB

Model	d	L	L1	L2	H
DN25	G 1"	90	39	67	70
DN32	G 1 ¼"	105	45	75	72
DN40	G 1 ½"	120	45	85	79

Measurements in mm unless otherwise specified.