



# ZTV/ZTR

Externally threaded 2- and 3-way zone valves



Valves used for control of hot and cold water in climate, heating and ventilation systems. They can also control glycol-mixed water in for example liquid connected recovery systems. Intended to be used together with the RVAZ4 actuators.

- ✓ Size DN15...DN25
- ✓ Kvs value 0.25...7.0
- ✓ Media temperature 1...110°C
- ✓ Pressure rating PN16
- ✓ Rangeability better than 50:1
- ✓ No leakage

## Application

### 2-way valve

The valve is open when the stem is in its lowest position and closed when the stem is in its upmost position.

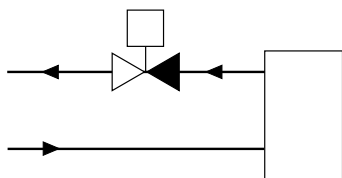

Fig. 1 2-way valve

### 3-way valve

The 3-way valve is closed between port A and port AB (the ports opposite to one another) when the stem is in its highest position. In this position, the valve is also open between the bottom port B and the common supply port AB. When the stem is in its lowest position, the 3-way valve is completely open between port A and port AB and

consequently closed between the bottom port B and the common port AB.

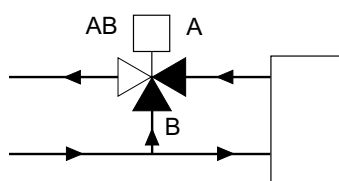

Fig. 2 3-way valve

## No leakage in closed position

The valve has O-ring sealing between plug and seat, which makes it completely tight in closed position. This makes the valve very energy-efficient.

## Installation

The 3-way valve is of a mixing type and must therefore be mounted in the mixing point.

- ✓ Before installation of the control valve, ensure that the pipe is clean. Make sure that pipe scale, metal chips, welding slag and other foreign materials are removed.
- ✓ For maximum efficiency and minimum wear, install the valve in a vertical position with the stem pointing upward. If the valve is mounted with the actuator on the side, more wear is caused to the valve packing box. The valve should never be mounted at an angle of more than 90°. At high media temperatures, the valve is to be mounted with the spindle to the side in order to minimise heating of the valve actuator.

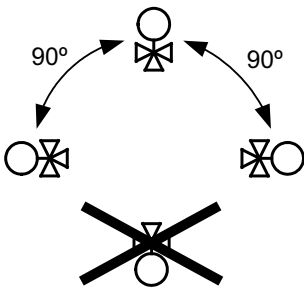

- ✓ Install the valve according to the fluid direction arrow shown on the valve.
- ✓ Make sure there is ample space above the valve to facilitate easy removal of the valve actuator.
- ✓ Fit a strainer/filter upstream of the valve to prolong the equipment's life span.
- ✓ A water quality according to VDI 2035 is recommended.

## Technical data

<b>Application</b>	Heating systems, cooling systems, fan-coil units, ventilation systems
<b>Pressure rating</b>	PN16
<b>Connection, actuator</b>	M30 x 1.5
<b>Connection</b>	BSP externally threaded according to ISO 228/1
<b>Flow characteristics</b>	Equal percentage
<b>Max. Leakage</b>	0 % of the kvs value
<b>Media</b>	Hot water, cold water, glycol-mixed water (max. 30 % glycol)
<b>Media temperature</b>	1...110 °C (the valve has a max. temperature of 140°C, the RVAZ4 actuators have a max. temperature of 110°C)
<b>Rangeability</b>	50:1
<b>Stroke</b>	5.5 mm

## Material

<b>Body</b>	Brass CW614N
<b>Seat</b>	Brass CW614N
<b>Plug</b>	Brass CW614N
<b>Stem</b>	Stainless steel 1.4305
<b>Seat packing</b>	EPDM
<b>O-rings</b>	EPDM

## 2-way valves

Article	Nominal diameter	Connection	Kvs	Max. diff. pressure	Actuator
ZTV15-0,25	DN15	G½"	0.25	350 kPa	RVAZ4
ZTV15-0,4	DN15	G½"	0.4	350 kPa	RVAZ4
ZTV15-0,6	DN15	G½"	0.6	350 kPa	RVAZ4
ZTV15-1,0	DN15	G½"	1.0	350 kPa	RVAZ4
ZTV15-1,6	DN15	G½"	1.6	350 kPa	RVAZ4
ZTV20-2,0	DN20	G¾"	2.0	250 kPa	RVAZ4
ZTV20-2,5	DN20	G¾"	2.5	250 kPa	RVAZ4
ZTV20-4,0	DN20	G¾"	4.0	150 kPa	RVAZ4
ZTV20-6,0	DN20	G¾"	6.0	150 kPa	RVAZ4
ZTV25-7,0	DN25	G1"	7.0	70 kPa	RVAZ4

## 3-way valves

Article	Nominal diameter	Connection	Kvs	Max. diff. pressure	Actuator
ZTR15-0,25	DN15	G½"	0.25	350 kPa	RVAZ4
ZTR15-0,4	DN15	G½"	0.4	350 kPa	RVAZ4
ZTR15-0,6	DN15	G½"	0.6	350 kPa	RVAZ4
ZTR15-1,0	DN15	G½"	1.0	350 kPa	RVAZ4
ZTR15-1,6	DN15	G½"	1.6	350 kPa	RVAZ4
ZTR20-2,0	DN20	G¾"	2.0	250 kPa	RVAZ4

HEAD OFFICE SWEDEN

Phone: +46 31 720 02 00

Web: [www.regincontrols.com](http://www.regincontrols.com)

E-mail: [info@regincontrols.com](mailto:info@regincontrols.com)

ZTV/ZTR

— 3 (7) —

  
THE CHALLENGER

Article	Nominal diameter	Connection	Kvs	Max. diff. pressure	Actuator
ZTR20-2,5	DN20	G $\frac{3}{4}$ "	2.5	250 kPa	RVAZ4
ZTR20-4,0	DN20	G $\frac{3}{4}$ "	4.0	150 kPa	RVAZ4
ZTR20-6,0	DN20	G $\frac{3}{4}$ "	6.0	150 kPa	RVAZ4
ZTR25-7,0	DN25	G1"	7.0	70 kPa	RVAZ4

### Connections for copper tubing

Article	Description	Connection	Valve
1885136	Nut and olive	$\frac{1}{2}$ ", K12	ZTV15, ZTR15
1886274	Nut and olive	$\frac{3}{4}$ ", K15	ZTV20 (kvs 2.0 - 2.5), ZTR20 (kvs 2.0 - 2.5)
1884709	Nut and olive	$\frac{3}{4}$ ", K18	ZTV20, ZTR20
1886282	Nut and olive	1", K22	ZTV25, ZTR25

### Steel pipe connection

Article	Description	Connection	Valve
OVC-Z15	Pipe connection	$\frac{1}{2}$ " (DN15)	ZTV, ZTR (DN15)
OVC-Z20	Pipe connection	$\frac{3}{4}$ " (DN20)	ZTV, ZTR (DN20)
OVC-Z25	Pipe connection	1" (DN25)	ZTV, ZTR (DN25)

### Suitable valve actuators

Article	Supply voltage	Control signal
RVAZ4-24	24 V AC $\pm$ 15 %	3-point
RVAZ4-24A	24 V AC/DC $\pm$ 15 %	0...10 V DC
RVAZ4-230	230 V AC $\pm$ 15 %, 50/60 Hz	3-point

## Dimensions

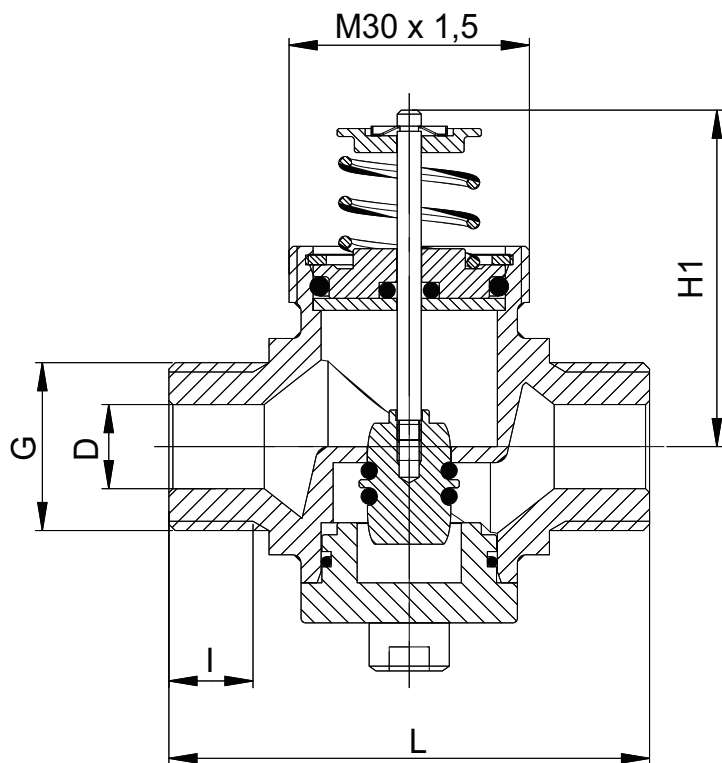

[mm], unless otherwise specified

### 2-way valve

Article	Connection	G	D (Ø)	I	L	H1
ZTV15-0,25	DN15	1/2"	12	9	60	42
ZTV15-0,4	DN15	1/2"	12	9	60	42
ZTV15-0,6	DN15	1/2"	12	9	60	42
ZTV15-1,0	DN15	1/2"	12	9	60	42
ZTV15-1,6	DN15	1/2"	12	9	60	42
ZTV20-2,0	DN20	3/4"	15	12,5	60	42
ZTV20-2,5	DN20	3/4"	15	12,5	60	42
ZTV20-4,0	DN20	3/4"	18	12,5	60	42
ZTV20-6,0	DN20	3/4"	18	12,5	60	42
ZTV25-7,0	DN25	1"	22	14	82	47

HEAD OFFICE SWEDEN

Phone: +46 31 720 02 00

Web: [www.regincontrols.com](http://www.regincontrols.com)

E-mail: [info@regincontrols.com](mailto:info@regincontrols.com)

ZTV/ZTR

— 5 (7) —

**REGIN**  
THE CHALLENGER

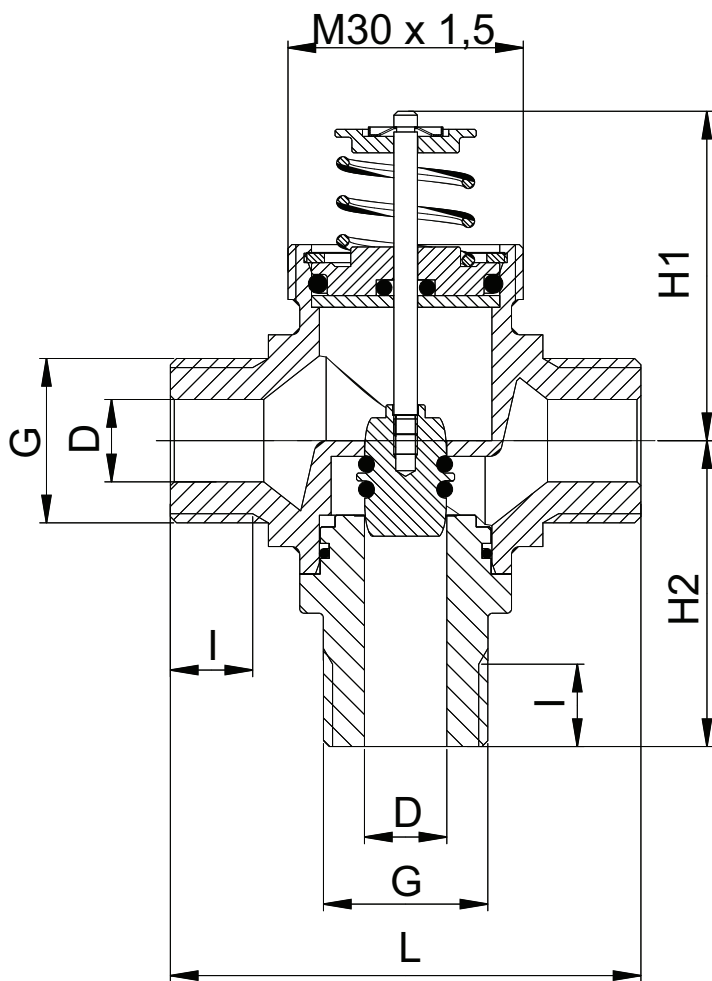

[mm], unless otherwise specified

### 3-way valve

Article	Connection	G	D (Ø)	I	L	H1	H2
ZTR15-0,25	DN15	½"	12	9	60	42	40
ZTR15-0,4	DN15	½"	12	9	60	42	40
ZTR15-0,6	DN15	½"	12	9	60	42	40
ZTR15-1,0	DN15	½"	12	9	60	42	40
ZTR15-1,6	DN15	½"	12	9	60	42	40
ZTR20-2,0	DN20	¾"	15	12,5	60	42	50
ZTR20-2,5	DN20	¾"	15	12,5	60	42	50
ZTR20-4,0	DN20	¾"	18	12,5	60	42	50
ZTR20-6,0	DN20	¾"	18	12,5	60	42	50
ZTR25-7,0	DN25	1"	22	14	82	47	44

# Pressure drop diagram

Pressure drop

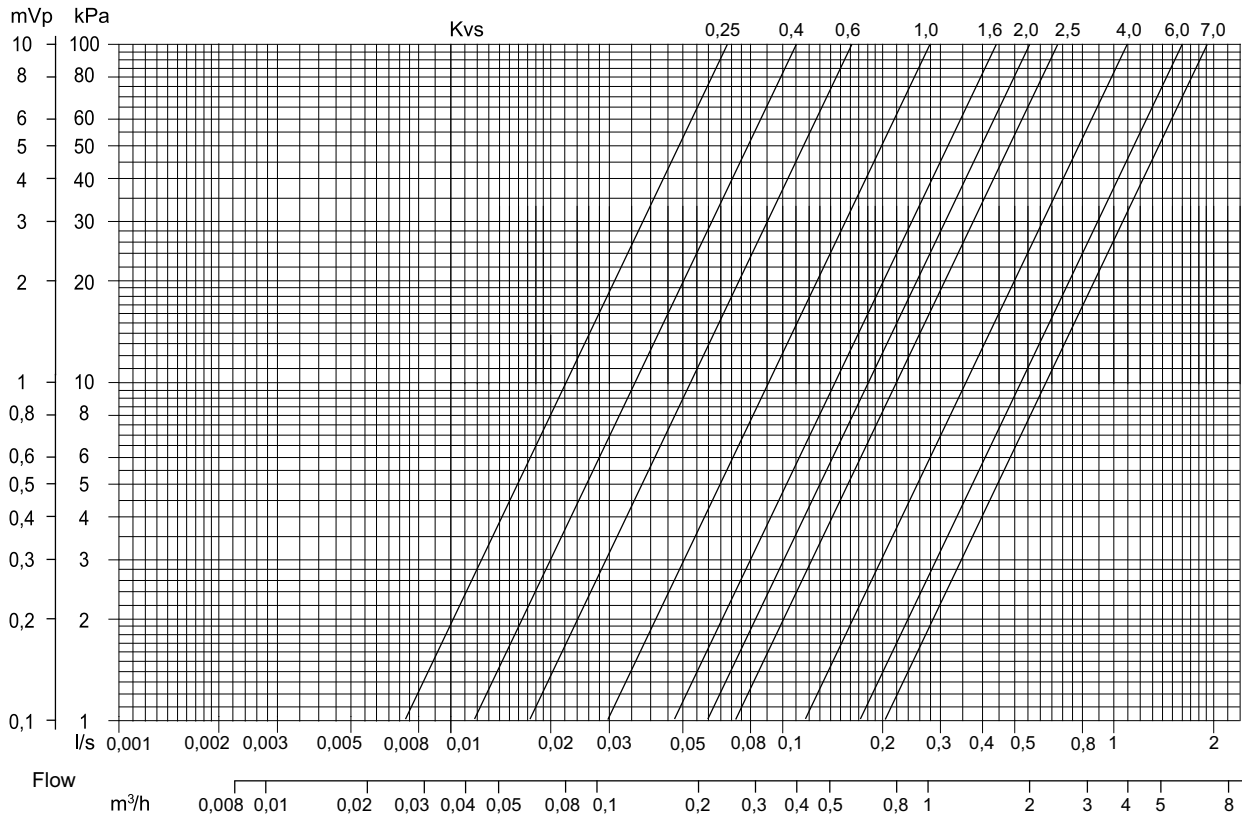

Pressure drop

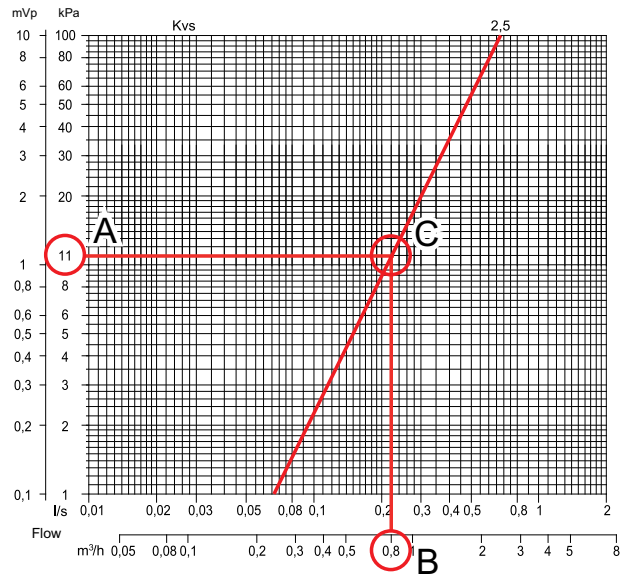

Fig. 3 Example, calculation of kv value If the pressure drop is 11 kPa (A) and the flow is 0.8 m³/h (B), the kv value is 2.5 (C). See the markings in the picture above.

## Documentation

All documentation can be downloaded from [www.regincontrols.com](http://www.regincontrols.com).