



## SSU

### Ultrasonic energy meters

Externally threaded, compact energy meters with built-in ultrasonic flow meter, intended for heating or cooling.

- ✓ Size DN15...DN40
- ✓ Nominal flow 0.6...10 m<sup>3</sup>/h
- ✓ For horizontal or vertical mounting
- ✓ Compact meter with easy-to-read display
- ✓ No moving parts enable flow measurement at low pressure drops
- ✓ Back flow detection
- ✓ Available with M-Bus, pulse output or M-Bus and 2 pulse inputs
- ✓ 230 V power pack available as accessory

### Function

The menu system, available in the display, makes it possible to read a large number of parameters, such as heat and cold consumption, total energy spent on heating and cooling, temperatures along with current energy consumption.

Installation is normally in the return pipe.

### Connection

The energy meter comes equipped with two PT1000 temperature sensors. The resistors for the sensors are composed of platinum and maintain a standard of DIN IEC 60751.

The return temperature sensor is integrated into the flow meter while the supply temperature sensor is connected via a cable.

### Mounting

The temperature sensor can be mounted directly in the media or in sensor pockets. The compact design of the energy meter allows it to be mounted even in narrow spaces.

More installation accessories are also available such as ball valves with installation point for a temperature sensor or pipe connection kits etc. See more under the heading **Accessories**.

### High reliability

The meter offers reliable and accurate performance over long periods of measurement.

### Flexible design

Due to the multiple combination options offered by its components, the meters can easily be adapted to suit a large number of individual requirements.

Models with M-Bus, pulse output or M-Bus + pulse input are available.

Energy meters with M-Bus have a default address of "0", which is not a valid primary communication address. This primary address can be changed by searching for secondary addresses (i.e. the ID number of the meter).

### Installation example, heating

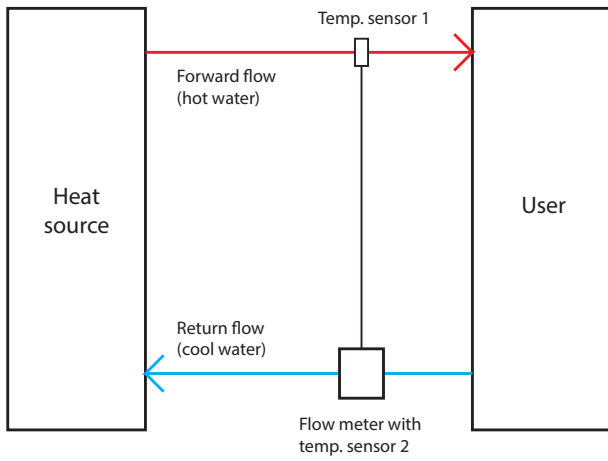

### Installation example, cooling

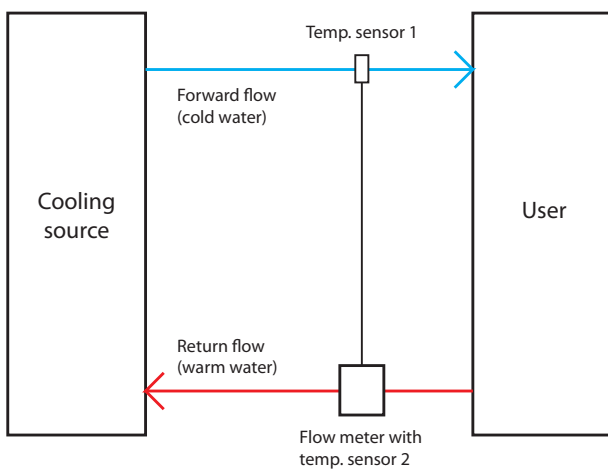

At first use, the installation position can be changed with the main button if forward flow installation is needed.

## Technical data, calculator

<b>Power supply</b>	Exchangeable 3 V lithium battery, estimated lifetime 10 years. 230 V power pack available as accessory.
<b>Temperature range, heating</b>	0...150 °C
<b>Temperature range, cooling</b>	0...50 °C
<b>Temperature difference range, heating</b>	3...100 K
<b>Temperature difference range, cooling</b>	-3...-50 K
<b>Temperature resolution</b>	0.01 °C
<b>Ambient temperature</b>	5...55 °C
<b>Storage temperature</b>	1...60 °C
<b>Ambient humidity</b>	Max. 95% RH
<b>Protection class</b>	IP65
<b>Calculation of heat from K</b>	$\Delta\theta > 0.05$ K
<b>Calculation of cooling from K</b>	$\Delta\theta < -0.05$ K
<b>Measurement cycle, temperature</b>	2...60 s
<b>Measurement cycle, temperature (using 230 V power pack)</b>	2 s
<b>Measurement cycle, flow</b>	2 s
<b>Data storage</b>	Non-volatile memory
<b>Interfaces</b>	M-Bus, pulse output or M-Bus with 3 pulse inputs
<b>Reading dates</b>	15 monthly and semi monthly values via display, 24 monthly and semimonthly values via optical interface or M-Bus. Annual billing date selectable.
<b>Display</b>	LCD, 8 digits + special characters
<b>Display units</b>	MWh, kW, GJ, m <sup>3</sup> , m <sup>3</sup> /h (kWh, GJ, l, l/h, MW, MMBTU, Gcal), 3 decimal places. The unit for energy consumption can only be set while the energy consumption is $\leq 10$ kWh.
<b>Mechanical class</b>	Class M1 (MID: 31.03.2004 annex I)
<b>EMC</b>	Class E2 (MID: 31.03.2004 annex I)
<b>Environmental class</b>	C (EN 1434)
<b>Dimensions, calculator (WxHxD)</b>	110 x 75 x 34.5 mm
<b>Cable length (measuring unit)</b>	85 cm

## Technical data, temperature sensor

<b>Cable length</b>	1.5 m (the other temperature sensor is integrated into the flow meter)
<b>Sensor element</b>	PT1000, DIN IEC 60751
<b>Diameter, sensor</b>	5 mm
<b>Installation</b>	Direct (see the accessories section) or indirect in a temperature sensor pocket per EN1434
<b>Temperature sensor requirements, heat meter</b>	EU (MID) identification on the temperature sensors
<b>Temperature sensor requirements, cooling meter</b>	National German approval as a temperature sensor for cooling meters. Requirements in other countries may be different.

## Technical data, flow meter

<b>Connection</b>	Threaded according to ISO 228/1
<b>Pressure rating</b>	PN16
<b>Media</b>	Water
<b>Mounting position</b>	Horizontal or vertical
<b>Point of installation</b>	Return flow (if forward flow installation is needed, the installation position can be changed with the main button)
<b>Temperature range</b>	15...90 °C
<b>Measuring principle</b>	Ultrasonic; time-of-flight
<b>Dynamic range <math>q_v/q_p</math></b>	1:100 (1:50 for $q_p 0.6$ )
<b>Accuracy according to MID</b>	Class 2
<b>Recommended minimum system pressure</b>	1 bar (to avoid cavitation problems)

## Models

Article	Nominal diameter	Nominal flow, $q_p$	Maximum flow, $q_s$	Minimum flow, $q_i$	Low flow threshold	Pressure drop at $q_p$	Pressure drop at $q_s$
SSU15-0.6...	DN15	0.6 m <sup>3</sup> /h	1.2 m <sup>3</sup> /h	12 l/h	6 l/h	0.03 bar	0.13 bar
SSU15-1.5...	DN15	1.5 m <sup>3</sup> /h	3.0 m <sup>3</sup> /h	15 l/h	6 l/h	0.21 bar	0.85 bar
SSU20-2.5...	DN20	2.5 m <sup>3</sup> /h	5.0 m <sup>3</sup> /h	25 l/h	12 l/h	0.115 bar	0.46 bar
SSU20-3.5...	DN20	3.5 m <sup>3</sup> /h	7.0 m <sup>3</sup> /h	35 l/h	14 l/h	0.21 bar	0.885 bar
SSU25-3.5...	DN25	3.5 m <sup>3</sup> /h	7.0 m <sup>3</sup> /h	35 l/h	14 l/h	0.21 bar	0.885 bar
SSU25-6.0...	DN25	6.0 m <sup>3</sup> /h	12 m <sup>3</sup> /h	60 l/h	30 l/h	0.20 bar	0.80 bar
SSU40-10...	DN40	10.0 m <sup>3</sup> /h	20 m <sup>3</sup> /h	100 l/h	50 l/h	0.24 bar	0.96 bar

## CE

This product carries the CE-mark. More information is available at [www.regincontrols.com](http://www.regincontrols.com).

## Ordering code selection table

Options	SSU...	-...	-...
<b>Flow (thread on meter body) (DN) (length of flow meter)</b>			
0.6 m <sup>3</sup> /h (G3/4") (DN15) (110 mm)	SSU15-0.6 <sup>1</sup>		
1.5 m <sup>3</sup> /h (G3/4") (DN15) (110 mm)	SSU15-1.5		
2.5 m <sup>3</sup> /h (G1") (DN20) (130 mm)	SSU20-2.5		
3.5 m <sup>3</sup> /h (G1") (DN20) (130 mm)	SSU20-3.5		
3.5 m <sup>3</sup> /h (G1¼") (DN25) (150 mm)	SSU25-3.5		
6.0 m <sup>3</sup> /h (G1¼") (DN25) (150 mm)	SSU25-6.0		
10.0 m <sup>3</sup> /h (G2") (DN40) (200 mm)	SSU40-10.0		
<b>Type of measurement and installation point</b>			
Heating, installation of flow meter in return pipe (MID approval)		-HR	
Cooling <sup>2</sup> , installation of flow meter in return pipe		-CR	
<b>Communication interface</b>			
M-Bus			-M
M-Bus with 3 pulse inputs <sup>3</sup>			-MPI
Pulse output for energy			-PO

<sup>1</sup> 0.6 is only available for heating, not for cooling

<sup>2</sup> National German approval.

<sup>3</sup> The standard setting for the pulse counters is 1 l/pulse. Please contact Regin if other values (10 l/pulse or 100 l/pulse) are needed.

If any further requirements or options are needed, for instance heating and cooling in combination, please contact Regin.

### Example 1:

Desired application: Meter with 1.5 m<sup>3</sup>/h. Heating, installation in return pipe. M-Bus.

Resulting item ordering number: **SSU15-1.5-HR-M**

#### Possible accessories needed:

- KH-¾, 2 pcs, ball valve connection for both sides of the meter, alternatively brass fittings VSR-½
- KH-S-¾, 1 pc, ball valve with installation point for a temperature sensor in supply flow, alternatively the adapter VAD-3/8 or VAD-1/2 for installation in a T-piece

### Example 2:

Desired application: Meter with 3.5 m<sup>3</sup>/h, DN25. Cooling, installation in return pipe. M-Bus + pulse input.

Resulting item ordering number: **SSU25-3.5-CR-MPI**

#### Possible accessories needed:

- KH-1¼, 2 pcs, ball valve connection for both sides of the meter alternatively brass fittings VSR-1
- KH-S-1¼, 1 pc, ball valve with installation point for a temperature sensor in supply flow, alternatively the adapter VAD-3/8 or VAD-1/2 for installation in a T-piece

## Accessories

### Threaded fitting with coupling ring and gasket \*

Article	Connection A	Connection B	Compatible with	Meter DN
VSR-1/2	G $\frac{3}{4}$	R $\frac{1}{2}$	q <sub>p</sub> 0.6/1.5 m <sup>3</sup> /h	15
VSR-3/4	G1	R $\frac{3}{4}$	q <sub>p</sub> 2.5/3.5 m <sup>3</sup> /h	20
VSR-1	G1 $\frac{1}{4}$	R1	q <sub>p</sub> 3.5/6.0 m <sup>3</sup> /h	25
VSR-1 1/2	G2	R1 $\frac{1}{2}$	q <sub>p</sub> 10 m <sup>3</sup> /h	40

\* Either the brass threaded fittings or the ball valves are to be used on each side of the flow meter. 2 pcs are required for each meter.

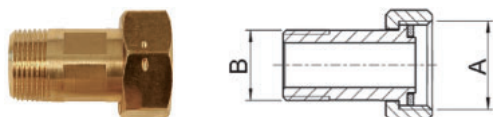

### Ball valve with coupling ring and gasket \*

Article	Connection A	Connection B	Compatible with	Meter DN
KH-3/4	Rp $\frac{3}{4}$	G $\frac{3}{4}$	q <sub>p</sub> 0.6/1.5 m <sup>3</sup> /h	15
KH-1	Rp1	G1	q <sub>p</sub> 2.5/3.5 m <sup>3</sup> /h	20
KH-1 1/4	Rp1 $\frac{1}{4}$	G1 $\frac{1}{4}$	q <sub>p</sub> 3.5/6.0 m <sup>3</sup> /h	25
KH-2	Rp2	G2	q <sub>p</sub> 10 m <sup>3</sup> /h	40

\* Either the brass threaded fittings or the ball valves are to be used on each side of the flow meter. 2 pcs are required for each meter.

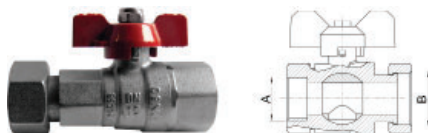

### Ball valve with installation point for a temperature sensor (socket M10x1)

Article	Connection A	Compatible with	Meter DN
KH-S-3/4	G $\frac{3}{4}$	q <sub>p</sub> 0.6/1.5 m <sup>3</sup> /h	15
KH-S-1	G1	q <sub>p</sub> 2.5/3.5 m <sup>3</sup> /h	20
KH-S-1 1/4	G1 $\frac{1}{4}$	q <sub>p</sub> 3.5/6.0 m <sup>3</sup> /h	25
KH-S-2	G2	q <sub>p</sub> 10 m <sup>3</sup> /h	40

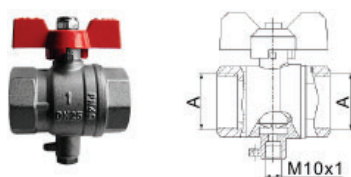

### Supply flow adapter with gasket, for direct mounting of a temperature sensor in a T-piece

Article	Connection A
VAD-1/2	G $\frac{1}{2}$ , M10x1
VAD-3/8	G $\frac{3}{8}$ , M10x1



## Threaded adapter to replace a flow meter temporarily or permanently

Article	Connection_A	Compatible with	Installation length	Meter DN
PS-110-3/4	G $\frac{3}{4}$	q <sub>p</sub> 0.6/1.5 m <sup>3</sup> /h	110 mm	15
PS-130-1	G1	q <sub>p</sub> 2.5 m <sup>3</sup> /h	130 mm	20
PS-150-1 1/4	G1 $\frac{1}{4}$	q <sub>p</sub> 3.5/6 m <sup>3</sup> /h	150 mm	25
PS-200-2	G2	q <sub>p</sub> 10 m <sup>3</sup> /h	200 mm	40



## Optical interface and read-out software

Article	Description
OPTO-CABLE-USB	Optocoupler with USB interface
OPTO-TOOL	Software device monitor



## 230 V power pack

Article	Description
POWERPACK-EM	230 V power pack
POWERPACK-EM-24	24 V AC power pack



## Spare parts

Article	Description
BATTERY-EM	Battery



## Pressure drop curves

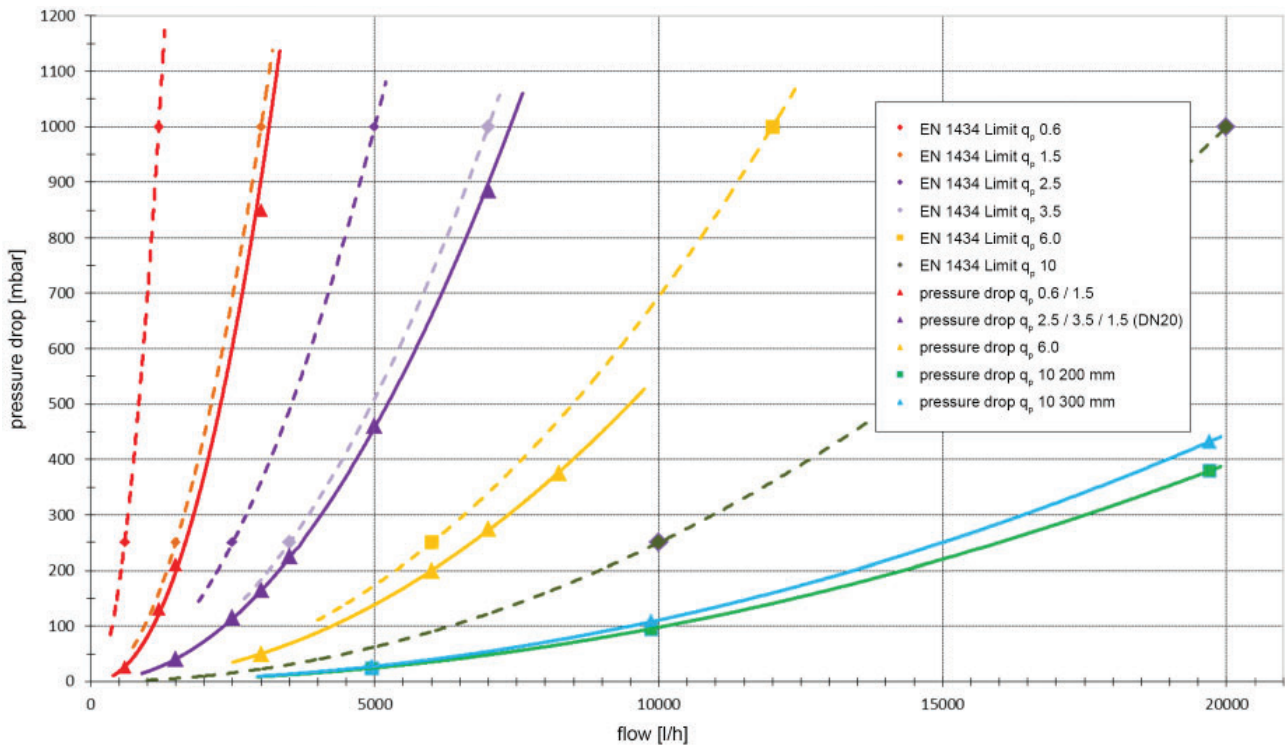

## Dimensions

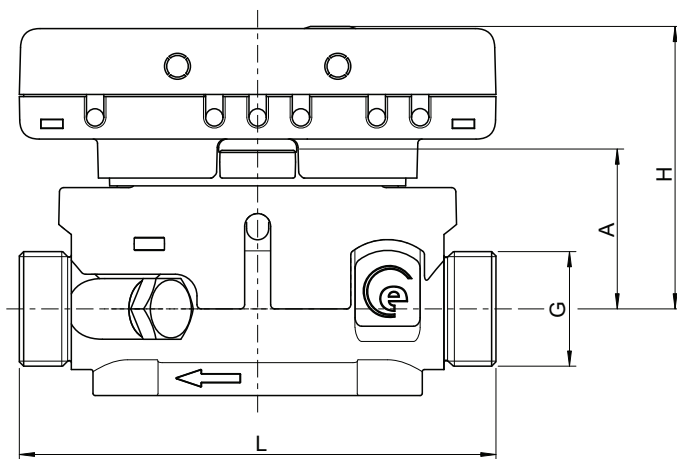

Qp (m³/h)	Nominal diameter	G (")	L	H	A
0.6	DN15	G3/4B	110	65	37
1.5	DN15	G3/4B	110	65	37
2.5	DN20	G1B	130	65	37
3.5	DN20	G1B	130	65	37
3.5	DN25	G1½B	150	65	37
6.0	DN25	G1½B	150	67.5	39.5
10.0	DN40	G2B	200	73	45

Measurements in mm unless otherwise specified.