

WE TAKE BUILDING  
AUTOMATION PERSONALLY

en

MANUAL  
EXOCLEVER EC-PU4-2



## THANK YOU FOR CHOOSING REGIN!

Ever since Regin was established in 1947, we have developed and marketed products and systems that create good levels of indoor comfort. Today, we are an important player with one of the market's broadest ranges for building automation.

Our goal is to make real estates in the world more energy efficient. Regin is an international group and our products sells in over 90 countries. Thanks to our global presence with strong local representation, we are well aware of the requirements of the market, as well as of how our products and systems function under the most variable conditions. Every year, Regin makes substantial investments in the development of our systems and HVAC-products.

### DISCLAIMER

The information in this manual has been carefully checked and is believed to be correct. Regin makes no warranties about the contents of this manual and users are requested to report errors and discrepancies to Regin, so that corrections may be made in future editions. The information in this document is subject to change without prior notification.

Some product names mentioned in this document are used for identification purposes only and may be the registered trademarks of their respective companies.

© AB Regin. All rights reserved.

Rev. B, 2023-02-15

---

1	Introduction .....	5
1.1	About this manual.....	5
1.2	More information.....	5
2	Information for the end user.....	6
2.1	Introduction .....	6
2.2	General information.....	6
2.2.1	With AC supply .....	6
2.2.2	With DC supply .....	6
2.2.3	Using an isolated communication port .....	6
2.2.4	Using the EFX port.....	6
2.2.5	System setup example.....	7
2.3	Status indicators.....	7
2.3.1	System status.....	7
2.3.2	Port status.....	8
2.4	Maintenance and Service .....	8
2.4.1	Changing the battery.....	8
2.4.2	Resetting the Application Memory .....	9
2.4.3	Updating the operating system .....	10
2.5	Using EC-PU4-2 with Add:io .....	10
2.6	Using EC-PU4-2 with EXOflex.....	10
2.6.1	Setting the base address of the expansion housing .....	10
3	Information for the specialist.....	12
3.1	Installation and wiring .....	12
3.1.1	Installation .....	12
3.1.2	Wiring .....	13
Appendix A	Technical data.....	14
A.1	EC-PU4-2 .....	14
A.1.1	General data.....	14
A.1.2	Operation .....	14
A.1.3	Storage .....	14
A.1.4	Battery.....	14
A.1.5	Communication port 1-3.....	14
A.1.6	EFX port.....	15
A.1.7	TCP/IP port .....	15
Appendix B	Model overview .....	16



# I Introduction

## I.1 About this manual

Special text formats used in the manual:



**Note!** This box and symbol is used to show useful tips and tricks.



**Caution!** This type of text and symbol is used to show cautions.



**Warning!** This type of text and symbol is used to show warnings.

**This box is used to show formulas and mathematical calculations**

This box is used to  
represent the display  
window on the  
controller

## I.2 More information

All the above documents are available for download from Regin's website, [www.regincontrols.com](http://www.regincontrols.com)

## 2 Information for the end user

### 2.1 Introduction

EXOclever is a range of freely programmable controllers for control, regulation, supervision and communication in automation installations. They offer great possibilities when constructing different types of control and regulation systems. EXOclever has a modular design that makes it easy to adapt the number and type of inputs and outputs required, as well as the type of communication needed by the individual client. EXOclever can be used either as stand-alone units or together with other EXO products as part of a larger automation system. In large automation systems, EXOclever is the basis, with EXOcompact and EXOdos as good supplements. Software applications such as EXOdesigner and EXOscada can be used to their full extent with EXOclever.

EC-PU4-2 supports Modbus master 3.0 and Controller Web.

### 2.2 General information

#### 2.2.1 With AC supply

The 24 V AC supply, typically a 230 V / 24 V transformer, is connected to contacts G0 (2), signal ground and G (1), phase.

The EMI earth must be connected to the earth rail or similar to protect against disturbances.



**Note!** The cable screen should be earthed at all isolated ports but only at one port if using unisolated ports (see section 2.2.5 *System setup example*).

---

#### 2.2.2 With DC supply

The 24 V DC supply, typically a stabilized power supply, is connected to contacts - (2) and + (1).

The EMI earth must be connected to the earth rail or similar to protect against disturbances.



**Note!** The cable screen should be earthed at all isolated ports but only at one port for each power source if using unisolated ports (see section 2.2.5 *System setup example*).

---

#### 2.2.3 Using an isolated communication port

- ✓ At longer distances (>30 m) or when experiencing communication problems, terminate bus with 100  $\Omega$  / 0.5 W in both ends.
- ✓ Shielded cables are preferable, use twisted pair with min. 24 AWG conductor size.
- ✓ Cable screen should be connected to "N" terminal at all connected ports (isolated).

#### 2.2.4 Using the EFX port

- ✓ At longer distances (>10 m) or when experiencing communication problems, terminate bus 100  $\Omega$  / 0.5 W in both ends.
- ✓ Shielded cables are preferable, use twisted pair with min. 24 AWG conductor size.
- ✓ Cable screen should be connected to "N" terminal at both ends (port isolated at PIFA end).

## 2.2.5 System setup example

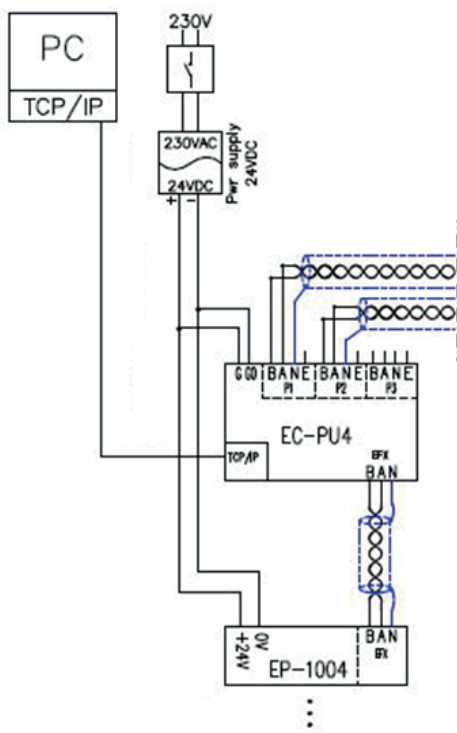
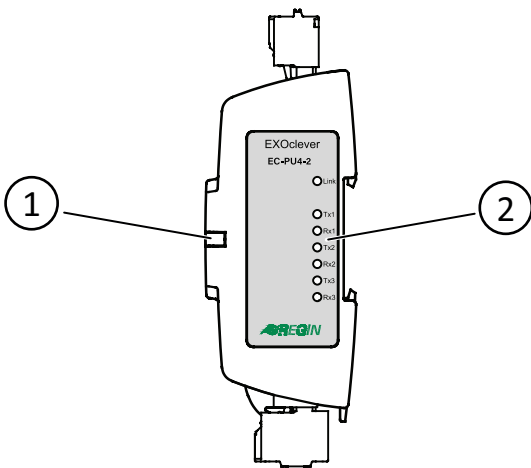

Figure 2-1 System setup example

## 2.3 Status indicators



- 1 System status indicator
- 2 Port status indicators

### 2.3.1 System status

EXOclevor EC-PU4-2 has a system status indicator (1) which can be inspected both when it is mounted on the backside or on its side. The indicator changes colour depending on system status.

Colour	Description
Green	Powered and all IO-units online.
Yellow (Blink 2.5 Hz)	Controller identification.
Red	Replace battery.
Orange (blink 1 Hz)	IO-unit connection problem.

### 2.3.2 Port status

On the label side of the EC-PU4-2 there are seven port status indicators (2).

Indicator	Description
TCP/IP Link	Lit when link is ok, flashing during communication.
P1 Tx	Lit when port P1 is transmitting data, intensity depends on data & communication speed.
P1 Rx	Lit when port P1 is receiving data, intensity depends on data & communication speed.
P2 Tx	Lit when port P2 is transmitting data, intensity depends on data & communication speed.
P2 Rx	Lit when port P2 is receiving data, intensity depends on data & communication speed.
P3 Tx	Lit when port P3 is transmitting data, intensity depends on data & communication speed.
P3 Rx	Lit when port P3 is receiving data, intensity depends on data & communication speed.

## 2.4 Maintenance and Service

### 2.4.1 Changing the battery

When the system status indicator is red, the battery for backup of program memory and the real-time clock has become too weak. The battery is replaced as described below. A backup capacitor saves the memory and keeps the clock running for at least 10 minutes after the battery has been removed. Thus, if battery replacement takes less than 10 minutes, there will be no need to reload the program and the clock will continue to run normally.

The replacement battery must be according to the specification in the *Appendix A Technical data* chapter.



**Caution!** Follow proper ESD precautions when changing the battery; i.e. an earthed wristband or similar protection must be used!

To change the battery:

1. Remove the DIN lock.





2. Gently bend the corners of the lid outwards.
3. Remove the lid.
4. Remove the battery by pulling it straight up from the holder. Note the polarity and push the new battery firmly in place.

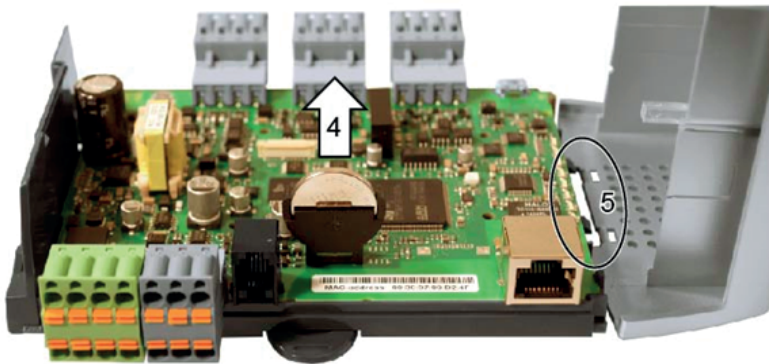

5. Mount the lid by aligning the notches into the holes in the lid and snap it on the opposite side.
6. Mount the DIN lock.



**Note!** If the battery is placed the “wrong way round”, the system status indicator will change to red to indicate a battery error when the controller is connected to the power supply.

Note that the system status indicator will not indicate a battery error if a battery is not mounted.

## 2.4.2 Resetting the Application Memory



**Caution!** This procedure should only be carried out by qualified system integrators since the current application will stop running and the controller will return to its factory application.

To reset the processor’s program memory (application programs) the controller has to be connected to the power supply. Use the reset button accessed through the small opening located to the right of the PORT 3 connector. Preferably use a non-metallic object when pressing the reset button since a metallic object could potentially short/damage the electronics next to the button if it slips of the button.

A recommendation is to use a wooden toothpick to access the reset button.

If the controller is not possible to reset in this way for some reason it should be powered down. Then keep the reset button pressed in while reconnecting the power.

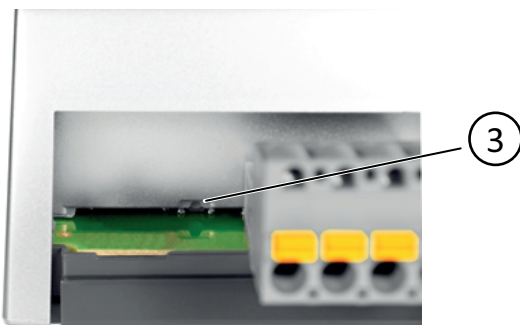

3

Reset button

### 2.4.3 Updating the operating system

The EXOreal operating system can be updated from EXOdesigner using any of the RS485 EXOline Slave ports or the TCP/IP port.

## 2.5 Using EC-PU4-2 with Add:io

EC-PU4-2 is intended for use with Add:io modules, to access analogue and digital inputs and outputs. The I/O modules and the EC-PU4-2 is mounted next to each other on a DIN-rail, and is connected with a shielded cable. All I/O modules must have a unique address between 2-32, which can be set with a DIP-switch on each separate I/O module. For more information, see the Add:io documentation at [www.regincontrols.com](http://www.regincontrols.com).

## 2.6 Using EC-PU4-2 with EXOflex

EC-PU4-2 can be used together with an EXOflex expansion housing (EH(X)0-S) that has a Power PIFA for Extender (EP1004) and any number of additional PIFA units.

An EXOflex processor housing (EH(X)1-S) can be converted to an expansion housing by removing the processor card and changing the Power PIFA (EP1011) to a Power PIFA for Extender (EP1004).

Note that you cannot use any communication PIFA:s, such as LON PIFA (EP8210), Basic Serial PIFA (EP8101), Dual Serial PIFA (EP8102) or TCP/IP PIFA (EP8282) together with EC-PU4-2. The communication port in EP7408 cannot be used together with EC-PU4-2 either.

### 2.6.1 Setting the base address of the expansion housing

The base address of the EXOflex housing should be set to 0.

In the housing, the base address is set using a group of jumper switches on the power PIFA. The base addresses are selected as follows:

Base address	Jumpers 3 2 1
28	: : :
24	: : <input type="checkbox"/>
20	: <input type="checkbox"/> :
16	: <input type="checkbox"/> <input type="checkbox"/>
12	<input type="checkbox"/> : :
8	<input type="checkbox"/> : <input type="checkbox"/>
4	<input type="checkbox"/> <input type="checkbox"/> :
0	<input type="checkbox"/> <input type="checkbox"/> <input type="checkbox"/> (use this setting)

3, 2 and 1 in the table refers to the jumpers for setting the base address in the below figure:

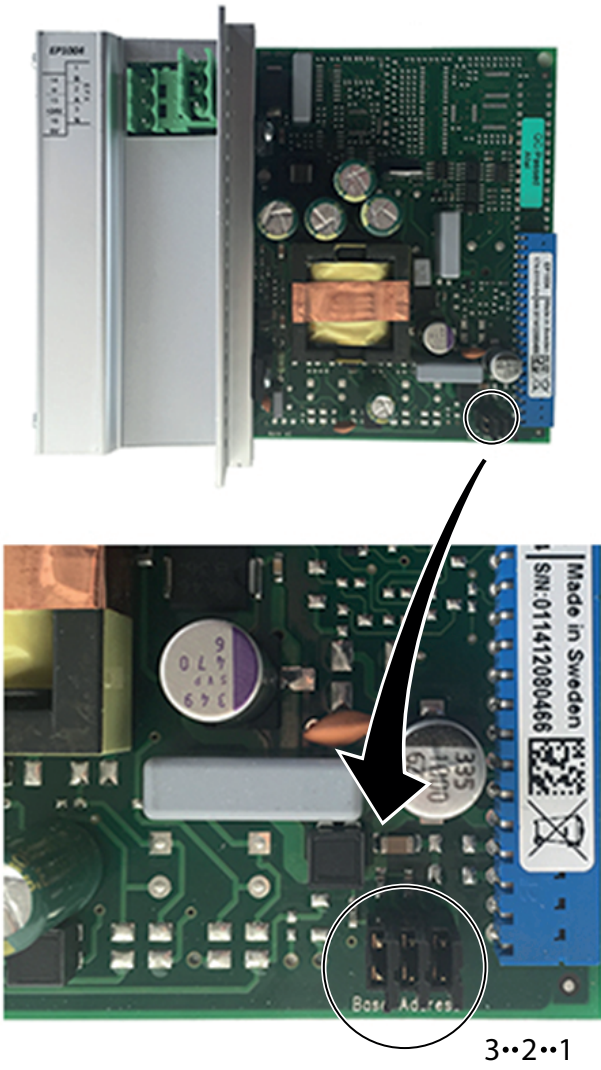

Figure 2-2 Jumpers

## 3 Information for the specialist

### 3.1 Installation and wiring

#### 3.1.1 Installation

EXOclever EC-PU4-2 is intended to be mounted on DIN-rail. It can be mounted on its backside, and it can also be mounted on the short side to save space.



EXOclever uses push-in connectors for easy cable installation. The push-in connectors have integrated test holes in each terminal for easy test measurements.

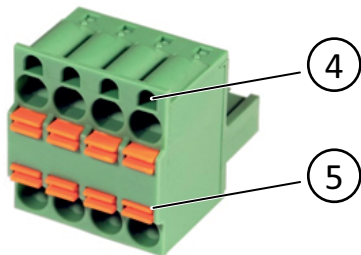

- 4 Test holes
- 5 Cable releaser

### 3.1.2 Wiring

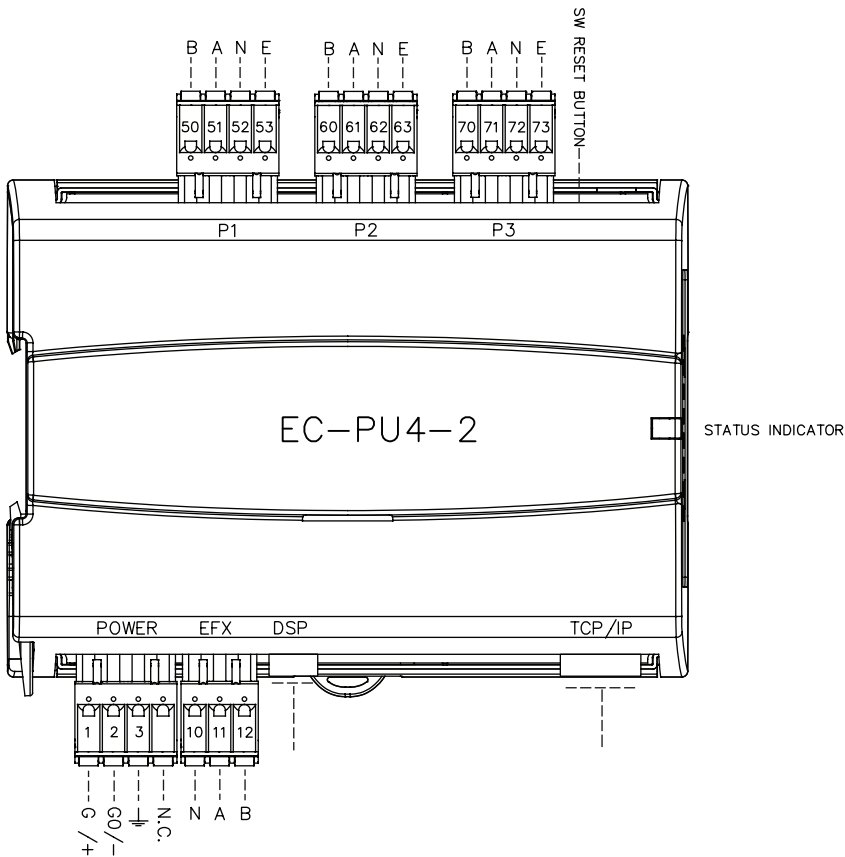

Table 3-1 Pinout P1-P3 ports

Pin	Signal	Signal description
50/60/70	B	Non-inverted (+) data signal line
51/61/71	A	Inverted (-) data signal line
53/63/73	E	Control signal, RS485

Table 3-2 Pinout POWER port

Pin	Signal	Signal description
1	G/+	Power input, 24 V AC or 24 V DC (+) at power supply
2	G0/-	System ground, 0 V connection (-) at power supply
3		EMI earth, connect to earth rail

Table 3-3 Pinout EFX port

Pin	Signal	Signal description
10	N	Cable screen earth
11	A	Inverted (-) data signal line
12	B	Non-inverted (+) data signal line

## Appendix A Technical data

### A.1 EC-PU4-2

#### A.1.1 General data

Supply voltage	24 V AC 50...60 Hz or 24 V DC
Tolerance	18...26 V AC / 22...30 V DC
Power consumption	10 VA / 5 W
Dimensions (WxHxD incl. terminals)	140 x 136 x 40mm
Mounting	DIN-rail
Protection class	IP20
Real-Time clock (RTC)	max ±20 sec./month
Operating system	EXOrealC
Application SRAM memory	768 kB available for user applications
Application flash memory (TCP/IP)	~7 MB available for user applications

#### A.1.2 Operation

Ambient temperature	0...55°C
Ambient humidity	Max. 95 % RH

#### A.1.3 Storage

Storage temperature	-20...+70°C
Storage humidity	Max. 95% RH

#### A.1.4 Battery

Battery type	Replacable Lithium cell, CR2032
Battery backup of RAM, RTC	5 Years
Battery monitoring	System status LED + Software accessible

#### A.1.5 Communication port 1-3

Type	RS485
Built-in protocol	EXOline
Other protocols	-
Control signal, RS485	E
Speed	Configurable, max 76800 bps
Standard speed	9600 bps
Galvanic isolation, common mode voltages	max. 150V
Max communication distance	1200 m (depending on communication speed)

### A.1.6 EFX port

Type	RS485
Communication speed	115200 bps
Galvanic isolation, common mode voltages	No
Max communication distance	300 m

### A.1.7 TCP/IP port

Type	10Base-T/100Base-TX auto-negotiation built-in protocol
EXOreal 3.4 or later	EXOlineTCP Slave, EXOlineTCP Master
	Modbus TCP Slave, BACnet/IP, HTTP, SMTP
Auto MDIX	Yes
Fast connector	shielded RJ45
Supported standards	IEEE 802.3u and IEEE 802.3x full-duplex flow control
Cable length (max)	100 m (min CAT 5e)

## Appendix B Model overview

Name	Supply voltage	Description
EC-PU4-2	24 V AC 50...60 Hz or 24 V DC	Processor unit, 4 communication ports







HEAD OFFICE AB Regin, Box 116, SE-428 22 Källered • Visiting address: Bangårdsvägen 35, SE-428 36 Källered  
Phone: +46 (0)31 720 02 00 • Fax: +46 (0)31 720 02 50 • [info@regincontrols.com](mailto:info@regincontrols.com) • [www.regincontrols.com](http://www.regincontrols.com)