



TG-UH/PT100

Outdoor temperature sensor with housing

Temperature sensor with PT100 element for outdoor temperature measurement or for use in areas requiring a higher protection class.

- Screw cap
- Tight casing, IP65

- Anti-tear cable gland
- Modern design and compact format

Tempero series temperature sensor with a modern design suiting all environments.

TG-UH/PT100 is intended for wall mounting, outdoors or in areas where a high protection class is required.

Technical data

Temperature range	-30...+70°C
Sensor element	PT100, 100 Ω/0°C, DIN class B
Cable gland	M16
Protection class	IP65

Material

Housing	Polycarbonate
---------	---------------

Colour

Cover	Polar white RAL9010
Base	Dark grey RAL7043

Temperature (°C)	Resistance (Ω)	Temperature (°C)	Resistance (Ω)
15	105.9	70	127.1
10	103.9	65	125.2
5	101.9	60	123.2
0	100.0	55	121.3
-5	98.0	50	119.4
-10	96.1	45	117.5
-15	94.1	40	115.5
-20	92.2	35	113.6
-25	90.2	30	111.7
-30	88.2	25	109.7
		20	107.8

Dimensions (mm)

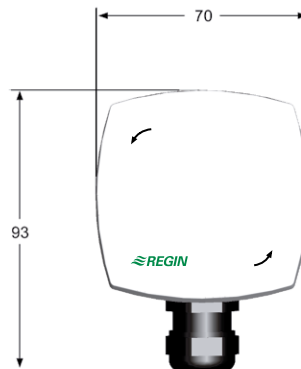

Head office Sweden

Phone: +46 31 720 02 00
 Web: www.regincontrols.com
 Mail: info@regin.se

REGIN

THE CHALLENGER IN BUILDING AUTOMATION