



TG-DH4/NTC2.2

Immersion sensor with housing

Temperature sensor with NTC2.2 element for water temperature measurement.

- Anti-tear M16 cable gland
- Bayonett mounted cover
- R1/4" connection

- Probe in stainless steel
- Modern design and compact format
- Simple and quick installation

Tempero series immersion sensor with a modern design suiting all environments.

The sensor is compatible with Johnson Controls.

Technical data

Temperature range	-20...+120°C
Compatible with	Johnson Controls
Sensor element	NTC 2.2k3A1, 2252 Ω/25°C
Time constant	4 s
Cable gland	M16
Insertion length	90 mm
Diameter, probe	5 mm
Connection	R1/4"
Pressure rating	PN16
Protection class	IP65

Material

Housing	Polycarbonate
Probe	Stainless steel, SUS304

Colour

Cover	Polar white RAL9010
Base	Dark grey RAL7043

Temperature (°C)	Resistance (Ω)	Temperature (°C)	Resistance (Ω)
35	1471	120	90
30	1814	110	115
25	2252	100	153
20	2813	90	207
15	3538	80	283
10	4482	70	395
5	5718	65	469
0	7353	60	560
-5	9533	55	673
-10	12460	50	811
-15	16428	45	984
-20	21860	40	1200

Dimensions (mm)

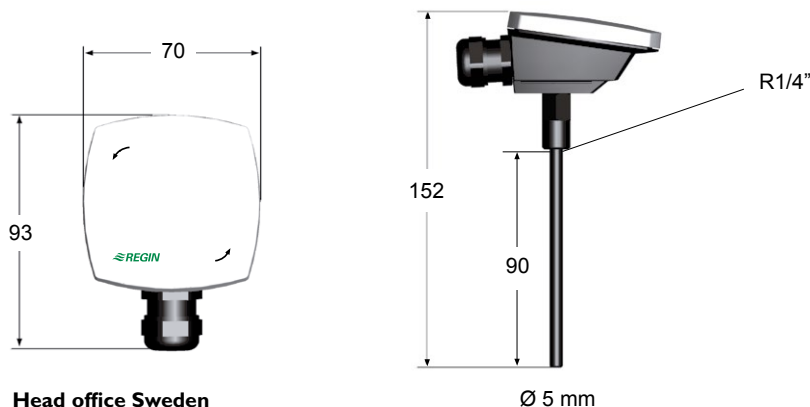

Head office Sweden

Phone: +46 31 720 02 00
 Web: www.regincontrols.com
 Mail: info@regin.se

REGIN

THE CHALLENGER IN BUILDING AUTOMATION