

de Montageanleitung
en Mounting instructions
fr Instructions de montage
sv Monteringsinstruktion
nl Montage-aanwijzing
it Istruzioni di montaggio
fi Asennusohje
es Instrucciones de montaje
da Monteringsvejledning

Drehantrieb
Rotary-type actuator
Servo-moteur à action angulaire
Spjällställdon med vridande rörelse
Luchtklepservomotor voor rot. aandrijving
Servocomando rotativo per serrande
Kiertoliikkeinen ilmapeltien toimimoottori
Actuador de acción rotativa
Motor for drejebælgelse

RDAS5-24C
RDAS10-24C

A

Lieferumfang
Deliverables
Contenu

Leverans
Leveringsomvang
Contenuto

Toimituslaajuus
Contenido
Leverancens omfang

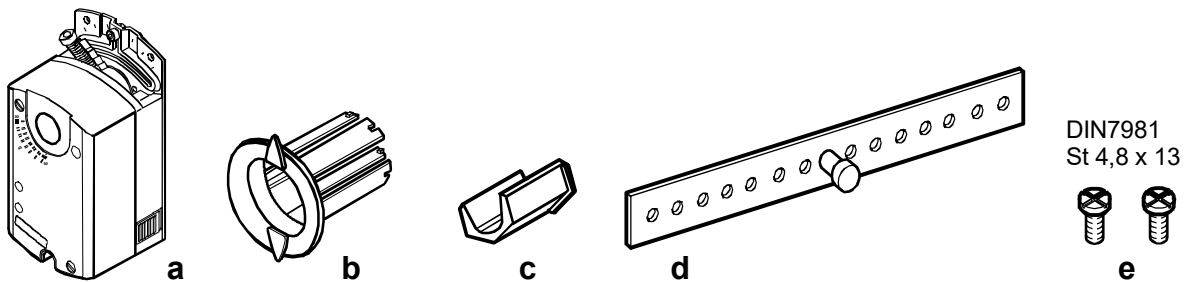

B

Hinweise / Warnungen
Notes / Warnings
Indications / Mise en garde

Hänvisningar / Varningar
Aanwijzingen / Waarschuwingen
Messa in servizio / Indicazioni

Huomauksia / Varoituksia
Indicaciones / Consejos
Bemærkninger / Advarsler

⚠ IP54

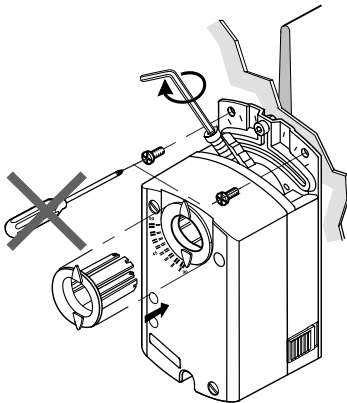



de

Diese Anleitung ist beim Antrieb oder in der Anlagendokumentation aufzubewahren!

 Dieses Symbol weist auf Gefahren und Massnahmen zum Schutz von Personen und Sachen hin:

- Antriebe für AC 230 V dürfen nur durch autorisiertes Personal angeschlossen werden.
- Zulässige Spannungen an den Hilfsschaltern: Siehe Tabelle unter "Geräteschaltpläne".
- Die Anschlusskabel des Antriebs dürfen nicht im Wasser liegen.

 Gerät der Schutzklasse II (Schutzisolierung)

 Gerät der Schutzklasse III (Schutzisolierung)

 **Achtung!** Der Stellantrieb darf nicht geöffnet werden

Voreinstellung

Werkseitig eingestellt: 5°.

Handverstellung des Antriebes

Nur bei montiertem Stellungsanzeiger gemäss Abschnitt C1 und C2 zulässig.

sv

Denna instruktion skall förvaras tillsammans med ställdonet eller anläggningsdokumentationen!

 Denna symbol gäller riskfaktorer samt åtgärder för att undvika person- och materialskador.

- Ställdon med AC 230 V får anslutas endast av behörig personal.
- Tillåten spänning för hjälpkontakter, se tabellen i avsnitt kopplingscheman.
- Ställdonets anslutningskabel får inte ligga i vatten.

 Apparat i isolerklasse II (skyddsisolering)

 Apparat i isolerklasse III (skyddsisolering)

 **OBS!** Ställdonet får inte öppnas.

Förinställning

Fabriksinställning: 5°.

Manuell manövrering

Endast tillåten efter och lägesindikator enligt avsnitt C1 och C2.

fi

Tätä ohjetta tulee säilyttää toimimoottorin läheisyydessä tai yhdessä laitosdokumenttien kanssa!

 Tämä symboli viittaa vaaraan ja toimenpiteisiin, joita tarvitaan henkilö- ja aineellisten vahinkojen välttämiseksi:

- Ainoastaan valtuutetut ammattihenkilöt saavat liittää 230 VAC:n toimimoottoreita.
- Sallitut jännitteet apukytkimissä: katso "Kytöntäkaaviot"-kappaleessa oleva taulukko.
- Toimimoottorin liitäntäkaapelit eivät saa kastua tai muuten altistua vedelle.

 Suojausluokan II laite (suoraerotus)

 Suojausluokan III laite (suojaerotus)

 **Huomio!** Toimimoottoria ei saa avata.

Akselin

Tehdasasetus: 5°.

Toimimoottorin käsiohjeus

Sallittua ainoastaan, ja asennonosoitin on asennettu paikoilleen kohtien C1 ja C2 mukaisesti.

en

Store these instructions together with the actuator or with the plant documentation!

 This symbol denotes dangers and measures to avoid personal injury and property damage:

- Only authorized personnel may connect actuators for AC 230 V.
- Refer to the table in "Diagrams" for the voltages permissible at the auxiliary switches.
- Do not expose the actuator's connecting cables to water or lay the cables in water.

 Device of protection class II (protective insulation)

 Device of protection class III (protective insulation)

 **Warning!** Do not open the actuator.

Presetting

Factory set: 5°.

Manual override of the actuator

Only allowed after position indicator, according to section C1 and C2.

nl

Deze handleiding moet bij de servomotor, of met de documentatie van de installatie worden bewaard!

 Dit symbool wijst op gevaar en maatregelen ter bescherming van personen en materiaal:

- AC 230 V aandrijvingen mogen alleen door bevoegd personeel worden aangesloten.
- Voor toelaatbare spanningen aan hulpschakelaars: Zie tabel onder "Aansluitschema's"
- De aansluitkabel van de aandrijving mag niet in het water liggen.

 Apparaat van beschermingsklasse II (beschermings isolatie)

 Apparaat van beschermingsklasse III (beschermings isolatie)

 **Opgelet!** De servomotor mag niet worden geopend.

Voorinstelling

Fabriekmatig ingestelde: 5°

Handmatige verstelling van de servomotor

Alleen toegestaan bij en standaanwijzers volgens voorbeeld C1 en C2

es

Conserve estas instrucciones con el actuador o con la documentación de la instalación!

 Este símbolo denota peligro y medidas para evitar daños personales y de la propiedad:

- Sólo el personal autorizado puede conectar los actuadores a 230 V CA.
- Consultar la tabla de "Conexión eléctrico" para saber la tensión permitida en los contactos auxiliares
- No exponer los cables de conexión del actuador al agua ni dejarlos en contacto con ésta.

 Equipo con tipo de protección II (aislamiento protegido)

 Equipo con tipo de protección III (aislamiento protegido)

 **Atención!** el actuador no debe ser abierto.

Preajuste

Ajuste de fábrica: 5°.

Posicionamiento manual del actuador

Sólo debe accionarse después del eje y el indicador de posición, según las secciones C1 y C2.

fr

Cette instruction est à conserver avec le servomoteur ou avec la documentation de l'installation!

 Ce symbole signale un danger pour les personnes et les biens et les mesures y-afférentes :

- Le branchement des servomoteurs 230 V~ ne doit être effectué que par un personnel qualifié.
- Tensions admissibles sur les contacts auxiliaires : cf. "Schémas de raccordement"
- Les câbles de raccordement du servomoteur ne doivent pas être en contact avec l'eau.

 Classe d'isolation II (isolation de protection)

 Classe d'isolation III (isolation de protection)

 **Attention!** Le servo-moteur ne doit pas être ouvert.

Préreglage

Préreglé à l'usine: 5°.

Positionnement manuel du servo-moteur

Ne doit être actionné d'axe et de l'indicateur de position, selon les sections C1 et C2.

it

Queste istruzioni devono essere conservate con la documentazione dell'impianto!

 Questo simbolo indica – pericolo – il personale deve fare attenzione per evitare ferite o danni.

- I collegamenti a 230 V CA . devono sempre essere eseguiti da personale autorizzati.
- Fare riferimento alle " tabelle tecniche" per la tensione ammessa per i contatti ausiliari.
- Non esporre all'acqua il cavo ed i collegamenti elettrici.

 Apparecchi di protezione classe II (protezione isolamento)

 Apparecchio di protezione classe III (protezione isolamento)

 **Attenzione!** Il servocomando non deve essere aperto.

Collega Regolazione

Alla consegna: 5°.

Posizionamento manuale del servocomando Può essere azionato dopo il e dall'indicatore di posizione secondo i paragrafi C1 e C2.

da

Opbevar denne vejledning sammen med motoren eller med anlægsdokumentationen!

 Dette symbol gør opmærksom på farer og forholdsregler til beskyttelse af personer og genstande:

- Motorer til AC 230 V må kun tilsluttes af autoriserede personer.
- Tilladte spændinger til hjælpekontakter: Se skema under "Apparatdiagrammer"
- Motorens tilslutningskabler må ikke ligge i vand.

 Apparat i isoleringsklasse II (beskyttelse-sisolering)

 Apparat i isoleringsklasse III (beskyttelse-sisolering)

 **OBS!** Motoren må ikke åbnes.

Forindstilling

Fabriksindstillet: 5°.

Manuel justering af motor

Kun tilladt med monteret stillingsindikator i henhold til afsnit C1 og C2.



Montage auf Klappenachse
 Shaft Mounting
 Montage sur l'axe des volets

Montering på spjällaxel
 Montage op de luchtklepas
 Montaggio sull'asse della serranda

Asennus pellin akseliin
 Montaje sobre el eje de las comp.
 Montering på spjældaksel

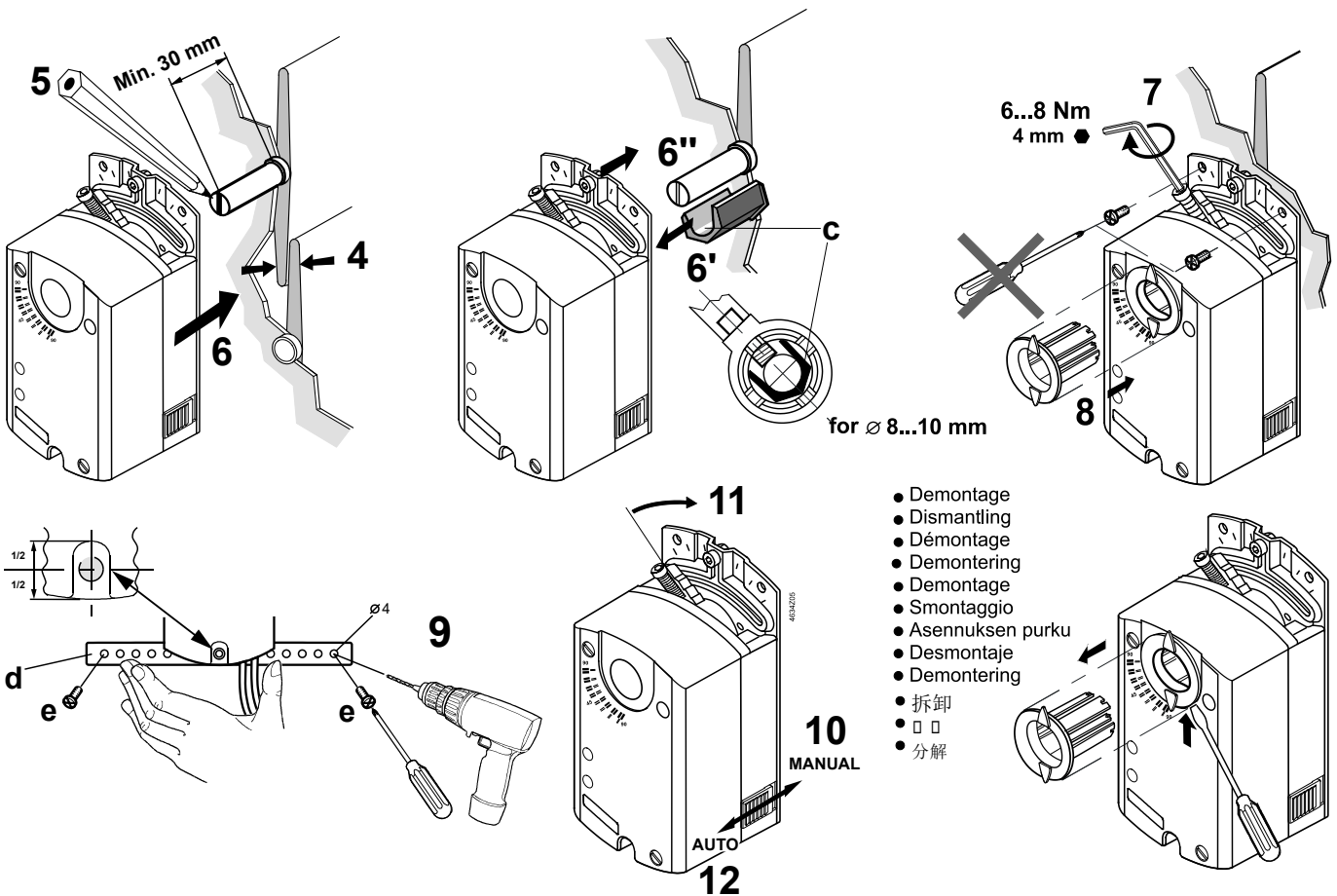
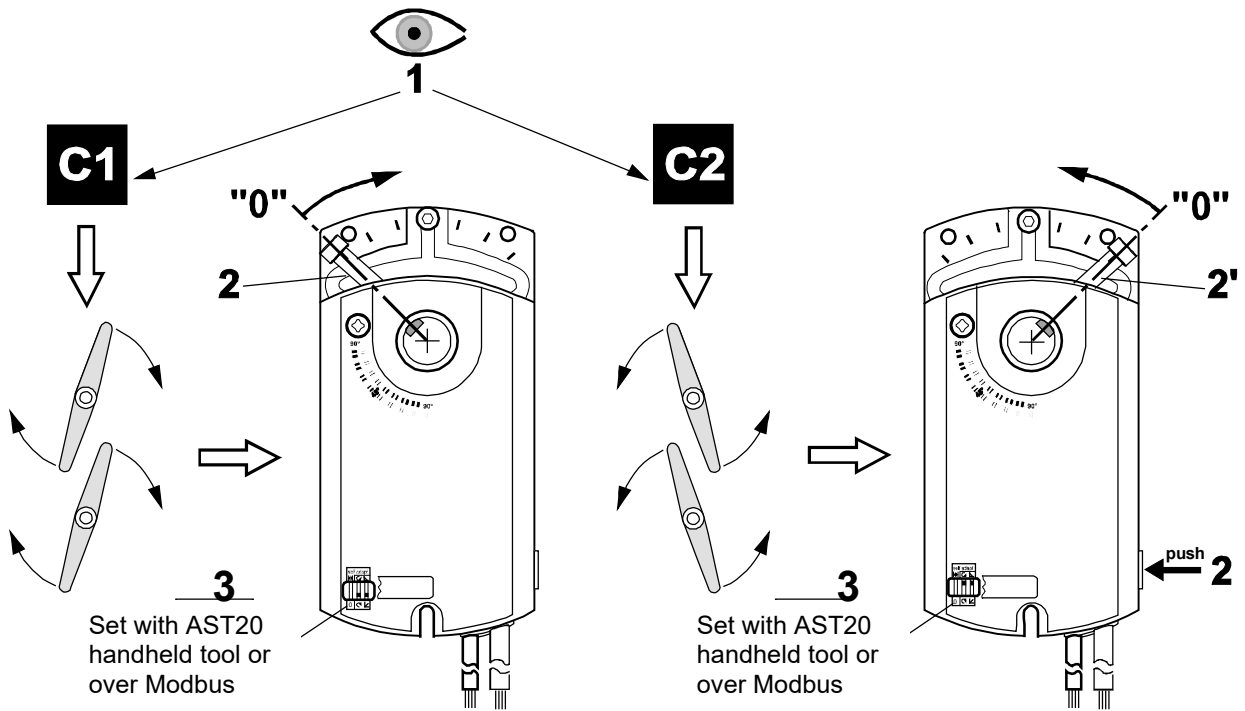

D

Drehwinkelbegrenzung
Limitation of rotary angle
Limitage de l'angle de rotation

Begränsning av vridningsvinkel
Begrenzing van de draaihoek
Limitatore dell'angolo di rotazione

Kääntökulman rajoitus
Límites del ángulo de rotación
Begrænsning af drejevinkel

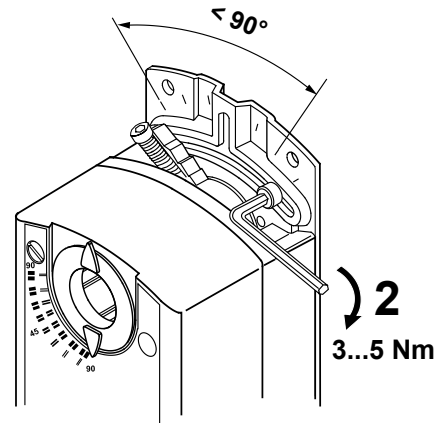
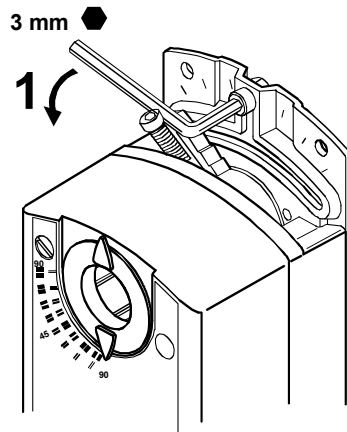



Massbild
Dimensions
Encombremnt

Måttuppgift
Maatschets
Ingombri

Mittapiirros
Dimensiones
Målskitse

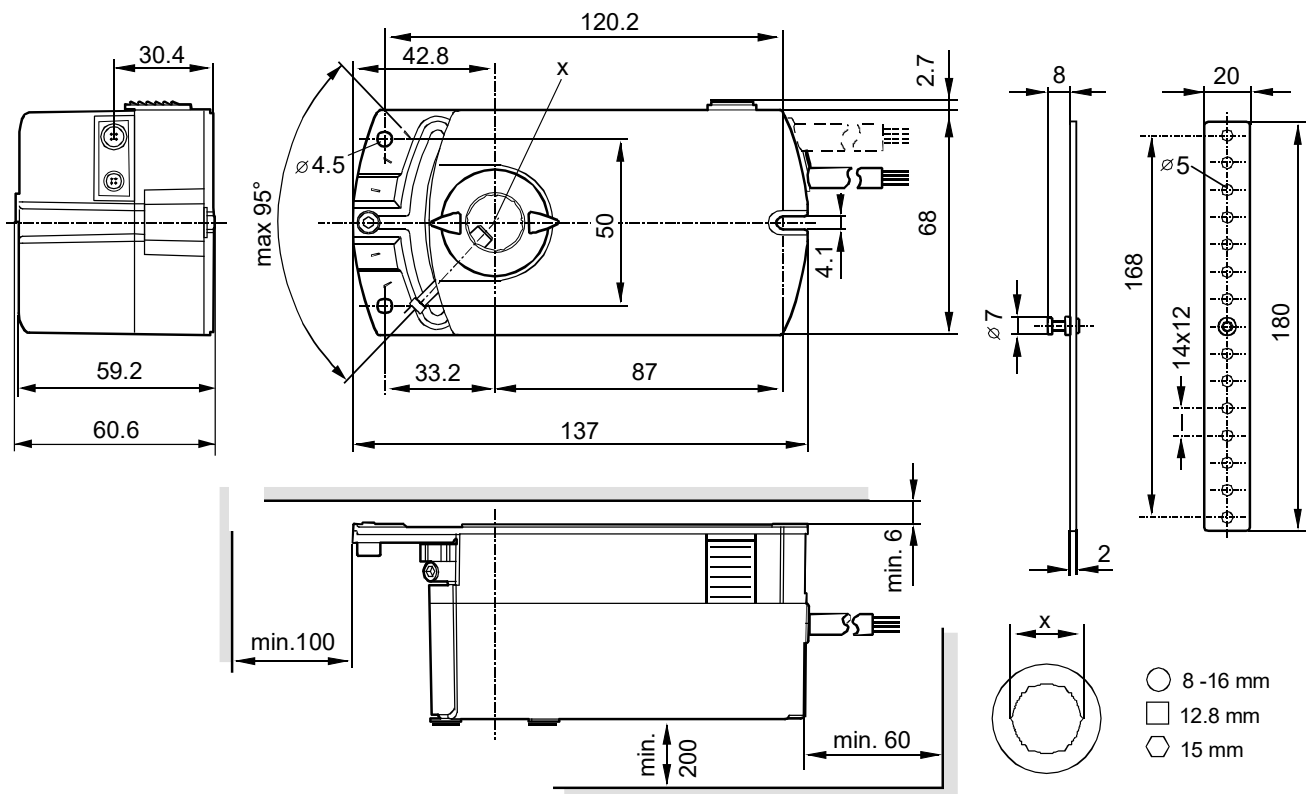

Masse in mm
Dimensions in mm
Dimensions en mm

Mått i mm
Afmetingen in mm
Dimensioni in mm

Mitat mm
Dimensiones en mm
Mål i mm

RDAS...-24C

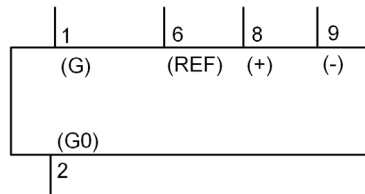
**AC 24 V**

Stetigsteuerung Modbus RTU
Modulating control Modbus RTU
Commande progressif Modbus RTU
Kontinuerlig styrsignal Modbus RTU
Modulerende besturing Modbus RTU
Comando analogico Modbus RTU
Jatkuva ohjaus Modbus RTU
Control continuo Modbus RTU
Kontinuerlig styring Modbus RTU

Code	No.	de Kabelbezeichnungen			en Wire designations			fr Désignation des câbles		
		Farbe	Abkürz.	Bedeutung	Color	Abbr.	Meaning	Câble	Abbr.	Signification
G	1	rot	RD	System Potential AC 24 V ~	red	RD	System potential AC 24 V ~	rouge	RD	potentiel du système AC 24 V ~
G0	2	schwarz	BK	Systemnull	black	BK	System neutral	noir	BK	zéro du système
REF	6	violett	VT	Referenz (Modbus RTU)	purple	VT	Reference (Modbus RTU)	violet	VT	reference (Modbus RTU)
+	8	grau	GY	Bus (Modbus RTU)	grey	GY	Bus (Modbus RTU)	gris	GY	bus (Modbus RTU)
-	9	rosa	PK	Bus (Modbus RTU)	pink	PK	Bus (Modbus RTU)	rose	PK	bus (Modbus RTU)