



WE TAKE BUILDING
AUTOMATION PERSONALLY



MANUAL EXIGO



REGIN
THE CHALLENGER

DISCLAIMER

The information in this manual has been carefully checked and is believed to be correct. Regin, however, makes no warranties in regard to the contents of this manual. Users are requested to report errors, discrepancies or ambiguities to Regin, so that corrections may be made in future editions. The information in this document is subject to change without prior notification.

The software described in this document is supplied under licence by Regin and may be used or copied only in accordance with the terms of the licence. No part of this document may be reproduced or transmitted in any form or fashion, electronically or mechanically, without the express, written permission of Regin.

COPYRIGHT

© AB Regin. All rights reserved.

TRADEMARKS

Exigo, E tool[®], EXOdesigner, EXOreal, EXOrealC, EXOline, EXO4, EXOscada, Optigo, Regio and Regio tool are registered trademarks of AB Regin.

Windows, Windows 2000, Windows XP, Windows Vista, Windows 7, Windows 8, Windows 8.1, Windows 10, Windows Server 2003, Windows Server 2008 and Windows Server 2012 are registered trademarks of Microsoft Corporation.

Some product names mentioned in this document are used for identification purposes only and may be the registered trademarks of their respective companies.

Revision C, March 2016

Software revision: 3.4

Table of contents

CHAPTER 1 ABOUT THIS MANUAL	5
More information	5
CHAPTER 2 ABOUT EXIGO	6
2.1 Application choice	6
2.2 Technical data	10
CHAPTER 3 INSTALLATION AND WIRING	12
3.1 Installation	12
3.2 Wiring	12
CHAPTER 4 COMMISSIONING	18
4.1 How to do it	18
CHAPTER 5 FUNCTIONAL DESCRIPTION	20
5.1 Heating system	20
5.2 Cooling system	23
5.3 Domestic hot water	24
5.4 Storage tank	25
5.5 Boiler control	25
5.6 Extra circuit	29
5.7 Cold water monitoring	30
5.8 Energy monitoring	30
5.9 Electricity meter	31
5.10 Timer channel outputs	31
5.11 Alarms	31
CHAPTER 6 DISPLAY, LEDS AND BUTTONS	32
6.1 Display	32
6.2 LEDs on E3-DSP (accessory for Exigo)	32
6.3 Buttons	32
6.4 Navigating the menus	33
CHAPTER 7 LOGGING ON	34
7.1 Log on	34
7.2 Log off	34
7.3 Change password	35
7.5 Change password to remove automatic logoff	35
CHAPTER 8 CONFIGURATION	36
8.1 Alarm settings	36
8.2 Inputs and outputs	38
8.3 Sensor settings	40
8.4 Supply	40
8.5 Return temperature limits	42
8.6 Boiler control	44
8.7 Pump stop	45
8.8 Twin/Single pump	46
8.9 Run indication/Motor protection	46
8.10 Actuator type	47
8.11 Running time, 3-position actuators	48
8.12 Valve exercise	48
8.13 Leakage monitoring	48
8.14 Pulse inputs	49
8.15 Alarm configuration	49
8.16 Communication	54
8.17 Other parameters	58
8.18 System	60

CHAPTER 9 SETTINGS	62
9.1 Actual/Setpoint	62
9.2 Control temp	66
9.3 Manual/Auto	67
9.4 Economy/Comfort function	70
9.5 Time/Extra timer outputs	71
9.6 Holidays	72
9.7 Energy/Cold water	72
9.8 Running mode	73
CHAPTER 10 EXPANSION UNITS	75
10.1 Ports 1, RS485	75
10.2 M-Bus	75
10.3 Wiring	75
CHAPTER 11 OTHER FUNCTIONS	77
11.1 Alarm handling	77
11.4 Optional information screen	77
11.5 Revision number	77
INDEX	78

Chapter 1 About this manual

This manual covers all the models in the Exigo series used with the heating application. This revision covers program revisions from 3.4.

More information

More information about Exigo can be found in:

- ***Manual E tool***[®] – Manual of how to configure the controllers using the PC software E tool[®]
- ***Exigo variables for EXOline, Modbus and BACnet*** – Variable list for EXOline, BACnet and Modbus communication, available in English
- ***Editable PDF files for Exigo***
- ***CE - Declaration of conformity, Exigo***
- ***Exigo product sheet*** – A general overview of the controller and its functions

The information is available for download from Regin's website, www.regincontrols.com.

Chapter 2 About Exigo

The Exigo series comprises three model sizes: 8, 15 or 28 in-/outputs.

Models from software revision 3.3 belong to the third generation and have article number E...-3 (where 3 stands for third generation). A new feature in version 3.3 are models with three communication ports. The 3 port Exigo models have article number E...3...-3 (where the initial “3” stands for 3 ports). For more detailed information, see chapter 10.

In each third generation model Exigo, all applications are loaded in a separate memory area. The controllers are available with or without a front panel display and buttons. For units without a front panel display and buttons, a separate, cable-connected terminal E3-DSP with display and buttons is available.

All configuration and normal handling can be done using the display and buttons or using the configuration tool E tool[®], installed on a PC and connected via the E-CABLE communication cable.

2.1 Application choice

On delivery, the main memory in the Exigo is empty. All the application programs that can be run in the Exigo are located in a separate memory area.

The initial screen shows the factory application. It contains options for setting up the Exigo before startup. Press the right arrow to select application:

```
→Application
  System
  Communication
  Time/Date
  Input/Output
```

Use the up/down arrows to move the arrow cursor in the left side of the display to the desired function. Select “Application” and press the right arrow.

```
Heating 3.4
Expansion unit 1
Expansion unit 2
```

Move the cursor to the desired application and press the right arrow.

```
Title:
Heating 3.4

Activate? Yes
```

Press ”OK” and change ”No” into ”Yes”. Press ”OK”.

The most recently loaded heating application will now be entered into memory. This will take approx. 30 seconds.

To change languages, press the right arrow 3 times when the start screen for selecting an application is displayed.

2.1.1 Additional menu options

System:

Information on the Exigo model and serial number.

EXOreal version.

MAC address and IP address.

Battery status and memory size.

Memory status and voltage frequency.

Communication:

Communication mode selection.

Serial:

Enables selecting EXOline address, communication speed, port mode and routing span.

TCP/IP:

Enables EXOline address selection and choice of DHCP (YES/NO).

Also enables manual IP address and subnet mask setting before the Exigo is initiated. Default gateway and DNS name are also available under this menu.

Possible to view current subnet mask, gateway and DNS name.

Main computer status.

Main computer IP address.

Permit connection to main computer.

TCP port routing to serial port 1 or 2.

Time/Date:

Permits setting the time and date.

Input/Output:

Enables in-/output reading and writing.

2.1 Heating application

The temperature controllers are PI-controllers for control of heating, cooling, boilers and PID for domestic hot water control. A number of different control functions, as well as analogue and digital inputs and outputs, can then be added to these controllers. The user can freely decide which functions to use. The only restriction is the number of physical in and outputs of the different models. Exigo is designed for mounting in a cabinet door, on a DIN-rail or a wall, or alternatively over a device box..

Among other things, the heating control program includes the following functions:

Heating control

Control of 1-3 heating systems with outdoor compensated supply temperature and optional room temperature influence via a room and/or return sensor.

Optimizer function

Optimising the start time in order to reach comfort temperature after economy mode.

Cooling control

Control of a cooling system with dew point control with fixed or outdoor compensated setpoint.

Domestic hot water

1 or 2 domestic hot water circuits and 1 storage-tank charger circuit.

Extra circuit

A differential thermostat function for transporting media between two places depending on the differential temperature.

Differential pressure control of pump

One constant differential pressure control circuit.

Boiler control

For control of 1-4 boilers in sequence, 1-step, 2-step or modulating burners. It is possible to choose between either a fixed or an outdoor compensated setpoint, or to use the highest setpoint in any other heating systems that have been configured.

Extra timer outputs

Up to 5 individually settable timer outputs for control of lighting, doorlocks etc.

Timer control

Year-based clock, individual schedulers, holiday scheduler.

Water monitoring

Digital input for displaying water consumption.

Energy monitoring

Digital input for displaying energy consumption.

Room setpoint

Room setpoint with control curve displacement.

Exigo hardware overview

	HC190D-1	HC191-1	HC191D-1	HC192DW-1	HC192W-1	HC193DWM-1
Analogue inputs	4	4	4	4	4	4
Digital inputs	2	2	2	2	2	2
Universal inputs*	4	4	4	4	4	4
Analogue outputs	2	2	2	2	2	2
Digital outputs	7	7	7	7	7	7
RS485		•	•	•	•	•
TCP/IP port Web server, EXOline, Modbus, BACnet/IP				•	•	•
Serial port EXOline, Modbus, BACnet MS/TP		•	•	•	•	•
1 port		•	•			
2 ports				•	•	
3 ports (2 + M-Bus connection)						•
Display	•		•	•		•
Power consumption (VA)	7.5	6.5	7.5	10	9	10.5

* Can be configured to function as either analogue input or digital input.

All Exigo controllers support external displays.

2.2 Technical data

Protection class	IP20, IP40 when mounted in cabinet
Display.....	4 rows of 20 characters, background illumination
Clock	Year-based 24 hour clock with battery backup. Automatic summer-/winter-time change-over.
Operating system	EXOreal
Supply voltage	230 V AC +10 % / -6 %
Dimensions	146.7 x 97.6 x 76.0 mm (WxHxD incl. terminals)
Mounting	In cabinet door, on DIN-rail or on wall, alt. over a device box
Operation	
Ambient temperature	0...50°C
Ambient humidity	Max 95 % RH, non-condensing
Transport	
Ambient temperature	-20...+70°C
Ambient humidity	Max 95 % RH, non-condensing
Storage	
Ambient temperature	-20...+70°C
Ambient humidity	Max 95 % RH, non-condensing

Battery

Type.....	Replaceable Lithium cell, CR2032
Battery life	5 years
Warning	Low battery warning
Battery backup.....	Memory and real time clock

Communication

EXOline port 1, insulated via a built-in RS485 contact.
EXOline via TCP/IP port.
BACnet/IP via TCP/IP port or BACnet MS/TP via RS485.
Modbus communication via serial RS485 communication or TCP/IP.

Suitable model selected for varying needs (see model overview, above).

EMC emissions & immunity standards

This product conforms to the requirements of the EMC Directive 2014/30/EU through product standard EN 61000-6-2 and EN 61000-6-3.

LVD

This product conforms to the requirements of the LVD Directive 2014/35/EU through product standards EN 60730-1 and EN 60730-2-9.

RoHS

This product conforms to the Directive 2011/65/EU of the European Parliament and of the Council.

Inputs

Analogue inputs AI..... Settable 0...10 V DC or PT1000, 12 bit A/D (-50...+150°C)

Digital inputs DI.....Potential-free closure

Outputs

Analogue outputs AO Configurable 0...10 V DC; 2...10 V DC;

..... 10...0 V DC or 10...2 V DC

.....8 bit D/A short-circuit protected

Digital outputs DODO 7x relay, 230 V AC, 1 A inductive load, max. 7 A total

Options

...W (TCP/IP port) EXOline, Modbus or BACnet communication

1 port One serial port

2 ports One serial port and one TCP/IP port

External hand terminal E3-DSP

3 ports One serial port, one TCP/IP port and M-Bus connection via terminal

Position of the terminals in the Exigo

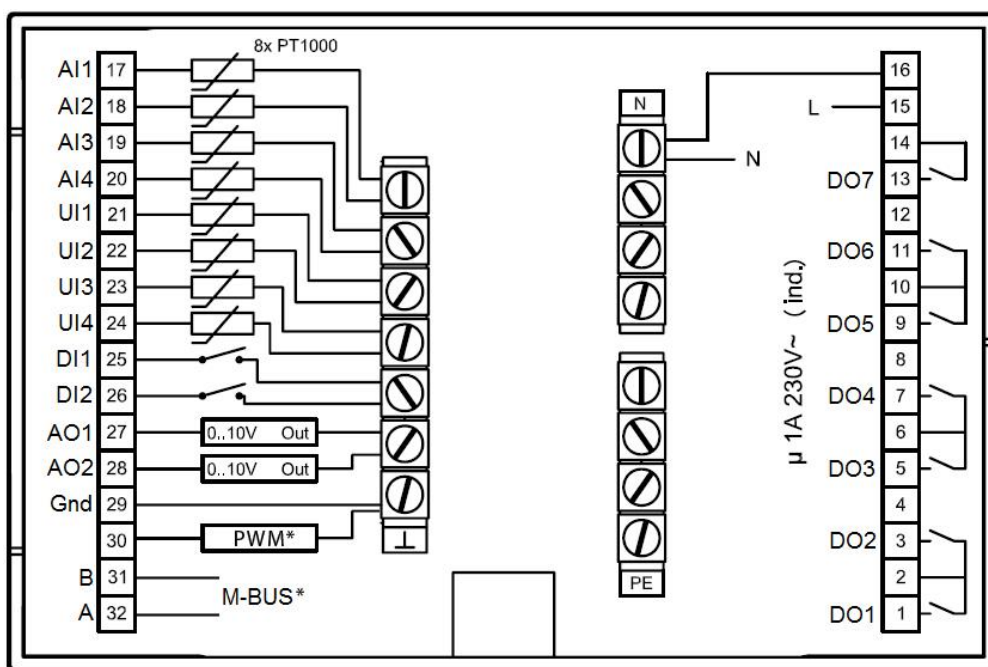

*Connection options depends on model

Chapter 3 Installation and wiring

3.1 Installation

Exigo can be mounted in a DIN-standard casing (minimum 9 modules), on a DIN-rail in a cabinet or, using a suitable front-mounting kit, in a cabinet door or other control panel.

Ambient temperature: 0...50°C.

Humidity: Max. 95 % RH, non-condensing.

3.2 Wiring

3.2.1 Supply voltage

85...265 V AC, 50/60 Hz.

3.2.2 Inputs and outputs

The list of input and output functions in section 3.2.3 is a handy instrument to help you keep track of which inputs and outputs you will need to configure.

Analogue inputs

Analogue inputs must refer to a  terminal.

Analogue inputs are intended for use with PT1000 sensors as a temperature sensor.

Digital inputs

Digital inputs must refer to a  terminal.

Universal inputs

A universal input can be configured to act as either an analogue input or as a digital input.

A universal input configured as an analogue input can be used with PT1000 temperature sensors.

Universal inputs configured as an analogue input must refer to a  terminal.

A universal input configured as a digital input must refer to a  terminal.

Analogue outputs

Analogue outputs must refer to a  terminal. The outputs can be individually set to any one of the following output signals:

0...10 V DC

2...10 V DC

10...0 V DC

10...2 V DC

Digital outputs

The relays are voltage-free and must receive power from a single pole for each relay.

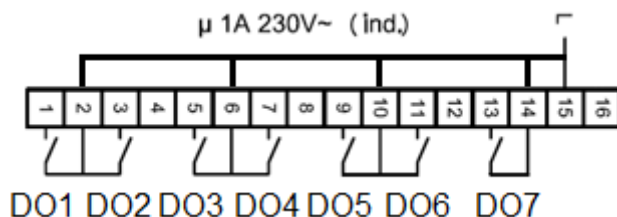

3.2.3 Input and output lists

The lists below are intended to be used as a memory aid during configuration, in order to help keep track of the desired input and output functions.

The left column contains a description of the in-/output signal, the middle column displays the name of the corresponding signal in E tool[®] and the right column shows the text displayed in the Exigo controller.

Analogue inputs

✓	Description	E tool [®]	Display
	Inactive input	Not active	Not active
	Outdoor temperature sensor	Outdoor temp	Outd temp
	Supply temperature, heating system 1	HS1, supply temp	HS1 supply
	Supply temperature, heating system 2	HS2, supply temp	HS2 supply
	Supply temperature, heating system 3	HS3, supply temp	HS3 supply
	Supply temperature, cooling system	CS1, supply temp	CS1 supply
	Domestic hot water circuit 1, supply temperature	HW1, supply temp	HW1 supply
	Domestic hot water circuit 2, supply temperature	HW2, supply temp	HW2 supply
	Storage tank supply temperature	HP1, supply temp	HP1 supply
	Room temperature, HS1,	HS1, room temp	HS1 room
	Room temperature, HS2	HS2, room temp	HS2 room
	Room temperature, HS3	HS3, room temp	HS3 room
	Room temperature, cooling system PT1000	CS1, room temp PT1000	CS1 room
	Return temperature, heating system 1	HS1, return temp	HS1 return
	Return temperature, heating system 2	HS2, return temp	HS2 return
	Return temperature, heating system 3	HS3, return temp	HS3 return
	Return temperature, cooling system	CS1, return temp	CS1 return
	Return temperature, hot water 1	HW1, return temp	HW1 return
	Storage tank return temperature	HP1, return temp	HP1 return
	Boiler system return temperature	Boiler return temp	HB return
	Heating primary, supply temperature	HP supply temp	HP supply
	Heating primary, return temperature	HP return temp	HP return
	Cooling primary, supply temperature	CP supply temp	CP supply
	Cooling primary, return temperature	CP return temp	CP return
	Extra temperature sensor 1	Extra sensor temp 1	Ext sensor1
	Extra temperature sensor 2	Extra sensor temp 2	Ext sensor2

✓	Description	E tool®	Display
	Extra temperature sensor 3	Extra sensor temp 3	Ext sensor3
	Extra temperature sensor 4	Extra sensor temp 4	Ext sensor4
	Extra temperature sensor 5	Extra sensor temp 5	Ext sensor5
	Boiler temperature	Boiler temp	HB supply
	Return temperature for boiler 1	Boiler 1 return temp	HB1 return
	Return temperature for boiler 2	Boiler 2 return temp	HB2 return
	Return temperature for boiler 3	Boiler 3 return temp	HB3 return
	Return temperature for boiler 4	Boiler 4 return temp	HB4 return
	Temperature for differential thermostat function	Extra circuit sensor 1	Ext circS1
	Temperature for differential thermostat function	Extra circuit sensor 2	Ext circS2
	Outdoor temperature for HS2	Outdoor temp HS2	HS2 outd temp
	Outdoor temperature for HS3	Outdoor temp HS3	HS3 outd temp
	Supply temperature, boiler 1	Boiler 1 supply temp	HB1 supply
	Supply temperature, boiler 2	Boiler 2 supply temp	HB2 supply
	Supply temperature, boiler 3	Boiler 3 supply temp	HB3 supply
	Supply temperature, boiler 4	Boiler 4 supply temp	HB4 supply

Digital inputs

✓	Description	E tool®	Display
	Inactive input	Not active	Not active
	Run indication/alarm circulation pump, P1A-HS1	HS1, pump A indication	HS1 pumpA
	Run indication/alarm circulation pump, P1B-HS1	HS1, pump B indication	HS1 pumpB
	Run indication/alarm circulation pump, P1A-HS2	HS2, pump A indication	HS2 pumpA
	Run indication/alarm circulation pump, P1B-HS2	HS2, pump B indication	HS2 pumpB
	Run indication/alarm circulation pump, P1A-HS3	HS3, pump A indication	HS3 pumpA
	Run indication/alarm circulation pump, P1B-HS3	HS3, pump B indication	HS3 pumpB
	Run indication/alarm circulation pump, P1A-CS1	CS1, pump A indication	CS1 pumpA
	Run indication/alarm circulation pump, P1B-CS1	CS1, pump B indication	CS1 pumpB
	Run indication/alarm circulation pump, P1-HW1	HW1, pump indication	HW1 pump
	Run indication/alarm, storage tank, charge pump P1-HP1	HP1, pump indication	HP1 pump
	Pressure switch, expansion vessel	Expansion vessel	Exp vessel
	External alarm	External alarm	External alarm
	Inactive input	Not active	Not active

✓	Description	E tool®	Display
	External power limit	External power limit	Ext pow limit
	Volume pulses, hot water usage	Water pulse	Water pulse
	Energy pulses, heating usage	Energy pulse	Energy pulse
	Volume pulse, cold water usage 1	CW1 pulse	CW1 pulse
	Volume pulse, cold water usage 2	CW2 pulse	CW2 pulse
	Energy pulse, electricity meter	Electric pulse	Electric pulse
	CS1 start	CS1, start	CS1 start
	Boiler alarm	Boiler alarm	Boiler alarm
	Run indication/alarm for boiler 1	Boiler 1 indication	HB1 ind
	Run indication/alarm for boiler 2	Boiler 2 indication	HB2 ind
	Run indication/alarm for boiler 3	Boiler 3 indication	HB3 ind
	Run indication/alarm for boiler 4	Boiler 4 indication	HB4 ind
	Run indication/alarm for pump/boiler 1	Boiler 1 pump indication	HB1 pump
	Run indication/alarm for pump/boiler 2	Boiler 2 pump indication	HB2 pump
	Run indication/alarm for pump/boiler 3	Boiler 3 pump indication	HB3 pump
	Run indication/alarm for pump/boiler 4	Boiler 4 pump indication	HB4 pump
	Run indication/alarm for the transport pump	Transport pump indication	Transp p A
	Boiler control external stop	External stop boiler 1-4	External stop
	Pressure/flow alarm for the boiler circuit	Boiler pressure/flow error	HB pres/flow
	Run indication/alarm for extra circuit (thermostat function)	Extra circuit pump indication	Ext circ pump
	Activates HS1 comfort mode	Extended running HS1	HS1 ext run
	Activates HS2 comfort mode	Extended running HS2	HS2 ext run
	Activates HS3 comfort mode	Extended running HS3	HS3 ext run

The universal inputs on a Exigo can be individually configured as either analogue inputs, using any of the analogue input signals above, or as digital inputs, using any of the digital inputs above.

Analogue outputs

✓	Description	E tool®	Display
	Inactive output	Not active	Not active
	Valve actuator, heating system 1, HS1	HS1, actuator	HS1 actuator
	Valve actuator, heating system 2, HS2	HS2, actuator	HS2 actuator
	Valve actuator, heating system 3, HS3	HS3, actuator	HS3 actuator
	Valve actuator, cooling system 1, CS1	CS1, actuator	CS1 actuator
	Valve actuator, hot water circuit 1, HW1	HW1, actuator	HW1 actuator
	Valve actuator, hot water circuit 2, HW2	HW2, actuator	HW2 actuator

✓	Description	E tool®	Display
	Split of any one of the above circuits (not differential pressure)	Seq control of actuator HS1-HP1	Seq control
	Burner, boiler 1	Boiler 1, modulating vessel	HB1 mod vessel
	Burner, boiler 2	Boiler 2, modulating vessel	HB2 mod vessel
	Burner, boiler 3	Boiler 3, modulating vessel	HB3 mod vessel
	Burner, boiler 4	Boiler 4, modulating vessel	HB4 mod vessel
	Valve actuator, return valve boiler 1	Boiler 1, return temp actuator	HB1 ret temp valve
	Valve actuator, return valve boiler 2	Boiler 2, return temp actuator	HB2 ret temp valve
	Valve actuator, return valve boiler 3	Boiler 3, return temp actuator	HB3 ret temp valve
	Valve actuator, return valve boiler 4	Boiler 4, return temp actuator	HB4 ret temp valve
	Highest setpoint for the configured circuits (0...100 degrees corresponds to 0...10 V)	Heat demand temp	Heat demand

Digital outputs

✓	Description	E tool®	Display
	Inactive output	Not active	Not active
	Start/stop pump, P1A-HS1	HS1, pump A start	HS1 pumpA
	Start/stop pump, P1B-HS1	HS1, pump B start	HS1 pumpB
	Start/stop pump, P1A-HS2	HS2, pump A start	HS2 pumpA
	Start/stop pump, P1B-HS2	HS2, pump B start	HS2 pumpB
	Start/stop pump, P1A-HS3	HS3, pump A start	HS3 pumpA
	Start/stop pump, P1B-HS3	HS3, pump B start	HS3 pumpB
	Start/stop pump, P1A, CS1	CS1, pump A start	CS1 pumpA
	Start/stop pump, P1B, CS1	CS1, pump B start	CS1 pumpB
	Start/stop pump, P1-HW1	HW1, pump start	HW1 pump
	Start/stop charge pump for storage tank, P1-HP1	HP1, pump start	HP1 pump
	Sum alarm A + B + C	Sum alarm	Sum alarm
	Sum alarm A	Sum alarm A	A-sum alarm
	Sum alarm B + C	Sum alarm B/C	B/C-sum alarm
	Extra time channel 1	Time channel 1	Timer1
	Extra time channel 2	Time channel 2	Timer2
	Extra time channel 3	Time channel 3	Timer3
	Extra time channel 4	Time channel 4	Timer4
	Extra time channel 5	Time channel 5	Timer5
	3-position actuator HS1, increase	HS1, actuator increase	HS1 inc act

✓	Description	E tool®	Display
	3-position actuator HS1, decrease	HS1, actuator decrease	HS1 dec act
	3-position actuator HS2, increase	HS2, actuator increase	HS2 inc act
	3-position actuator HS2, decrease	HS2, actuator decrease	HS2 dec act
	3-position actuator HS3, increase	HS3, actuator increase	HS3 inc act
	3-position actuator HS3, decrease	HS3, actuator decrease	HS3 dec act
	3-position actuator CS1, increase	CS1, actuator increase	CS1 inc act
	3-position actuator CS1, decrease	CS1, actuator decrease	CS1 dec act
	3-position actuator HW1, increase	CS1, actuator increase	CS1 inc act
	3-position actuator HW1, decrease	HW1, actuator decrease	HW1 dec act
	3-position actuator HW2, increase	HW2, actuator increase	HW2 inc act
	3-position actuator HW2, decrease	HW2, actuator decrease	HW2 dec act
	Bypass valve, CS1	CS1, bypass valve	CS1 bypass valve
	CS1, cooling unit start	CS1 cool unit start	CS1 cooling unit
	Start/stop burner 1	Boiler 1, vessel	HB1 start1
	Start/stop burner 1, high effect	Boiler 1, vessel (high effect)	HB1 start2
	Start/stop burner 2	Boiler 2, vessel	HB2 start1
	Start/stop burner 2, high effect	Boiler 2, vessel (high effect)	HB2 start2
	Start/stop burner 3	Boiler 3, vessel	HB3 start1
	Start/stop burner 3, high effect	Boiler 3, vessel (high effect)	HB3 start2
	Start/stop burner 4	Boiler 4, vessel	HB4 start1
	Start/stop burner 4, high effect	Boiler 4, vessel (high effect)	HB4 start2
	Start/stop pump, boiler 1	Boiler 1, pump start	HB1 pump
	Start/stop pump, boiler 2	Boiler 2, pump start	HB2 pump
	Start/stop pump, boiler 3	Boiler 3, pump start	HB3 pump
	Start/stop pump, boiler 4	Boiler 4, pump start	HB4 pump
	Start/stop transport pump A	Transport pump A start	Transp p A
	Start/stop extra circuit pump	Extra circuit pump	Ext circ pump
	Start/stop transport pump B	Transport pump B start	Transp p B

Chapter 4 Commissioning

General

Before the Exigo can be used, all inputs and outputs must first be configured, as well as all relevant parameters.

All commissioning can be performed using the Exigo front panel display and buttons, or by using the external display unit E3-DSP. However, the easiest way is to use E tool[®], see below.

E tool[®]

The best way to configure Exigo is by using E tool[®].

E tool[®] is a PC-based configuration program specially developed to simplify the commissioning of the Exigo series.

When using E tool[®] the whole configuration and all settings can be done on the computer and then be downloaded to the Exigo. An infinite number of configurations can be stored in the computer memory for later use.

A communication cable is required in order to configure Exigo. E-CABLE-USB, E-CABLE2-USB or E-CABLE-RS232 are used for controllers featuring RS485 communication, and E-CABLE-TCP/IP for controllers with a TCP/IP port.

The Exigo must be powered up and the application selected in order for it to be configured.

4.1 How to do it

For configuration using E tool[®], see the E tool[®] manual.

For configuration using the front panel or E3-DSP, there are two ways to go depending on how much help you need.

Option 1:

- Jump straight to chapter 6 and 7, *Display, LEDs and buttons* and *Access rights*.
- After learning how to use the buttons and menu system, connect power to your Exigo, log on as Admin and go to the menu "Configuration".
- For the time being, skip the configuration menu Inputs/Outputs and start by configuring control functions.
- Run through the configuration menus in order and set whatever functions and parameters you wish to include. Use chapter 5 of this manual for reference. Keep track of which inputs and outputs you will need for the functions you will activate. To help you, there is a list of input and output functions provided, see section 3.2.3.
- Finally, configure In-/Outputs.
- Exit the "Configuration" menu and go to "Settings".
- Set the control values in "Settings".
- Set the clock and scheduler functions in "Time Settings".
- Set the control setpoints in "Actual/Setpoint".

Your Exigo should now be ready for operation.

Option 2:

Read this manual in the order given below: The manual has been designed to act as a guide through the commissioning process. The last chapters of the manual, not listed below, cover menus and functions that are not used during commissioning.

Functional description

Start by reading chapter 5, *Functional description* below. Some functions are essential to the working of the unit and must be included. Others are more of the nature of optional extras which can be excluded.

At the end of each function description there is a table of the necessary inputs and outputs to implement the function. At the end of the manual there is a list of all the analogue and digital inputs and outputs. As you read, mark in the list the inputs and outputs you will be using for the application you are building. Note that the universal inputs can be individually configured as either analogue or digital inputs.

Display, buttons and LEDs

Read chapter 6 on how to use the front panel buttons to navigate the Exigo menu system.

Logging on

Chapter 7. How to log on with various access levels.

Configuration

Chapter 8, *Configuration*.

Connect power to the Exigo. Using the buttons and menu system, go through the configuration menus covering the functions you wish to use.

On delivery the units already have the inputs and outputs assigned to various functions. These can, of course, be changed.

Settings

Set the control parameters, P-band, I-time for the temperature control loops and pressure control used in section 9.2, *Control temp*.

Set the alarm parameters; alarm levels and delay times in section 8.1, *Alarm settings*.

Clock

Section 9.5.

Set the clock and calendar functions.

Setpoints

Section 9.1.

Set all the setpoints for all active control loops.

Manual/Auto

Section 9.3.

Learn to use manual control. Very useful for testing out and troubleshooting your system.

Other functions

Chapter 11.

Alarm handling, etc.

Chapter 5 Functional description

5.1 Heating system

5.1.0 General

Exigo can be configured for 1 to 3 heating systems, HS1, HS2 and HS3, as well as 1-2 domestic hot water systems, HW1 and HW2. It is also possible to configure boiler control of 1-4 boilers, the only limitation being the number of inputs/outputs.

5.1.1 Controllers

The heating circuits are controlled by PI-controllers with settable P-band and I-time.

5.1.2 Control curves

The controllers have individual outdoor temperature / supply temperature control curves. Each curve has 8 breakpoints. The default setting of the outdoor temperature values for the breakpoints are -20, -15, -10, -5, ± 0 , +5, +10, +15. The corresponding supply temperatures are pre-set to 67, 63, 59, 55, 53, 43, 35 and 25. Both the outdoor and supply temperature values are settable, either via the display or by using E tool[®].

5.1.3 Auto-correction of setpoint

Room sensors can be used to correct the set control curves. The average temperature over a period of time is calculated and will parallel displace the entire curve up or down, depending on whether the difference between the room setpoint and actual room temperature is negative or positive. After the comparison, the deviation is multiplied by the correction factor and the sum is added to the present displacement according to the following formula:

$$\text{Displacement} = (\text{Room setpoint} - \text{Average temp}) * \text{Factor} + \text{current displacement}$$

The frequency of this calculation can be set between 0...24 h. At 0 h, a calculation is made every minute and at 24 h a calculation is made once every day. The correction factor is adjustable 0...100. The current displacement has a limitation of $\pm 20^{\circ}\text{C}$, which is selectable (FS = $\pm 6^{\circ}\text{C}$). The current room temperature must be between 10...30 $^{\circ}\text{C}$ for the function to activate, and the outdoor temperature must be in between the X coordinates on the outdoor compensated curve (i.e. outdoor temperature FS -20...+15 $^{\circ}\text{C}$).

5.1.3.1 EcoGuard via EXOline

EcoGuard can be used instead of a physically (AI) connected room sensor. It uses the RS485 port to register values from the sensors connected to an EcoGuard unit.

It is possible to select to which HS circuit/s (one or several) that the EcoGuard should be connected. Please note that it is not possible to use both EcoGuard and a physically connected (AI) sensor for the same HS circuit.

In order to connect EcoGuard to Exigo, it is first necessary to configure a RS485 port to "Expansion unit/External sensor".

EcoGuard makes use of the fixed PLA:ELA address 200:241, load number 10 and cell number 0 (pre-set in EcoGuard).

5.1.4 Temperature limits

The heating systems have individually settable min. and max. temperature limits on the supply and return. If the return temperature is not within the set limits, the supply temperature will be adjusted with a settable factor to eliminate the error. However, the supply setpoint will never fall below/exceed the set min./max. setpoint.

The supply displacement minimum limitation is calculated according to:

$$\text{Supply displacement} = (\text{Min. limitation} - \text{Return temp.}) * \text{Limitation factor}$$

(The supply displacement can only provide a positive displacement; otherwise the displacement will = 0).

The supply displacement maximum limitation is calculated according to:

$$\text{Supply displacement} = (\text{Max. limitation} - \text{Return temp.}) * \text{Limitation factor}$$

(The supply displacement can only provide a negative displacement; otherwise the displacement will = 0).

Primary and secondary return temperature limits

The primary return temperature must not be more than 3 degrees (settable) higher than the secondary return temperature. When the difference exceeds the set value, the control signal to the valve will be overridden to close the valve, i.e. decrease the flow, which will lower the return temperature.

Inputs and outputs

AI	Return temperature HS1 and/or HS2
AI	Return temperature Heating primary

5.1.5 Starting and stopping HS1

It is possible to limit the heating output by using the function “UnitShutDown”. This is a digital input used to “Start/Stop” HS1-3. Frost protection must be activated if this function is to be used.

5.1.6 Prioritise heating system (HS) over domestic hot water (DHW) and storage tank (HP1)

Exigo contains a function for prioritising the heating system circuits over domestic hot water/storage tank. This can be useful when it is very cold outside and the system is somewhat undersized. When one of the HS circuits falls below the setpoint by a settable amount of degrees for a settable amount of time, the DHW actuators will be forced to close.

5.1.7 Pump control

Each system can have a single or double pumps. Double pumps are run one at a time with automatic, weekly change-over and automatic backup pump start on malfunction of the active pump.

Outdoor temperature dependent pump stop can be configured, as well as individual pump start and pump stop delays.

Pumps are exercised for 5 minutes at 3 pm daily.

5.1.8 Frost protection

If a controller is set to Off or Manual control and the outdoor temperature is below a settable value, a minimum, settable supply temperature will be maintained and the pump will run.

5.1.9 Wind compensation

To compensate for wind chilling, it is possible to connect a wind sensor and generate a setpoint displacement according to a settable factor. The function has a settable displacement factor (°C per m/s).

5.1.10 Building inertia and boost

The building inertia in relation to the heat storage capacity of the building shell is settable in hours (0...24).

The set inertia dictates the influence of the outdoor temperature on the control curves.

The outdoor temperature used to calculate the current supply temperature is an average value during the set time. To use the current outdoor temperature the time should be set to 0, and to obtain a daily average it should be set to 24.

Boost: Boost is used to speed up the raising of the indoor temperature when switching from night set back temperature to normal comfort temperature. This is done by temporarily displacing the supply temperature set-point curve. The following conditions must be met:

- Average outdoor temperature lower than 17°C
- Supply set-point value higher than 25°C
- Night set-back more than 2°C (room temperature)

The displacement is calculated as follows:

```
Displacem.=Factor*(17 - outdoor temp)*night set-back
```

The factor is settable 0...10 where 0 gives no boost and 10 gives maximum boost.

The time in minutes that boost will be active is calculated as follows:

```
Time = 1.6*(17 - Outdoor temp)
```

The duration is limited to a maximum of 60 minutes.

5.1.11 Night set-back

Lowering of the night temperature is set in room temperature degrees. The corresponding lowering of the supply temperature is calculated by the controller by multiplying the value by 3. Exigo has individual schedules for each heating system, with two comfort-temperature periods per day.

The digital inputs "Extended running HS1-HS3" can be used to activate comfort mode during the night set-back. The inputs have settable on/off-delays.

5.1.12 Start time optimisation

This function is used in order to reach the set room temperature when comfort time is activated after a period of night set-back. How far in advance the supply temperature is to be increased is calculated as below:

```
Optimisation time = (Setpoint Room - Actual value Room) / Heating capacity
```

The heating capacity has a minimum and a maximum value (factory setting minimum value: 0.02°C/min, maximum value: 0.1°C/min). The average of the min. and max. capacities is used as the start value for the function. Then the capacity is converted as below:

```
Heating capacity = (Heating capacity + Temperature boost / Optimisation time) / 2
```

Here, the temperature boost is equal to the difference in room temperature when the optimisation was stopped and when it was started.

Outdoor compensated start time optimisation

When outdoor compensation of the start time optimisation is active, the compensated capacity is calculated as below:

$$\text{Outdoor compensated capacity} = \text{capacity} * (1 + \text{Outdoor compensation} / 100 * \text{Outdoor temperature diff})$$

The outdoor compensation is a settable percentage between 0...100 % (0 % = no compensation). The factory setting is 3 %.

“Outdoor temperature diff” is the difference between the actual outdoor temperature and the outdoor temperature at the latest optimisation.

Inputs and outputs

AI	Room sensor
----	-------------

5.1.13 Power limitation

The digital input signal *External power limitation* can be used to temporarily restrict power to the heating systems. When activated, the setpoints are lowered by a settable factor (relative to 20°C). The limitation applies to all configured heating systems.

The limitation is calculated as below:

$$\text{Limited setpoint} = 20 + (\text{Setpoint} - 20) * \text{Factor} / 100$$

Factor 100 gives no setpoint reduction, 0 gives full reduction to 20°C.

5.1.14 Power limitation M-Bus

The serial port (RS485) can either be set to Slave, Expansion units/External sensor or to M-Bus, but the latter option requires an X1176 interface converter. By connecting a district heating meter to the M-Bus port, the function "Power limitation" can be used to restrict the permitted power to HS1. This function can e.g. be used to give priority to certain customers, such as nursing homes, when there is not sufficient power to meet the requirements of all users. A setpoint is entered for the maximum permitted power output for HS1. If the output exceeds this setpoint, HS1 is controlled by two controllers. The controller with the lowest output signal will be controlling the actuator.

5.2 Cooling system

5.2.1 General

A cooling system can be configured. The cooling system setpoint can be constant or outdoor compensated.

5.2.2 Controller

The cooling system is controlled by a PI-controller with settable P-band and I-time. The controller uses a temperature sensor input for supply temperature cooling circuit, and an analogue output for control valve cooling.

5.2.3 Pump control

In the cooling system, a digital output can be used to control the pump. The pump can be configured to run continuously or with pump stops. Pump stops are activated via the outdoor temperature sensor. It is also possible to add a pump stop delay and a pump start delay. During pump stops, the output to the actuator is 0 V.

5.2.4 Start of cooling unit

A digital output can be configured to start/stop the cooling unit. The output follows the pump settings, with the only difference being that exercising the pump does not affect the output.

5.2.5 Eco/Comfort function

The Exigo has a schedule for the cooling system with two comfort-temperature periods per day. When not in the comfort periods, a settable increase of the setpoint is added to the supply in order to reduce energy consumption.

5.2.6 Temperature limit

The supply temperature can be max. limited via a fixed settable value. It is also possible to min. and max. limit the return temperature. When the return temperature falls below the minimum limit or exceeds the maximum limit, the supply setpoint will be overridden with a settable factor.

5.2.7 Bypass valve (frost protection in the primary cooling system)

In the cooling system, a digital output can be used to control a bypass valve. The conditions for the CS1 bypass valve to open is for the outdoor temperature to fall below 3°C and for the CS1 valve to be closed (0 %). If any of these conditions are not met, the CS1 bypass valve will be closed.

5.3 Domestic hot water

5.3.1 General

Exigo can be configured for one or two domestic hot water systems, HW1 and HW2. These have constant supply temperature control. If one chooses to connect an electric heater to the system, flow guards for both HW1 and HW2 are available as configuration options. These guards will then shut the control off if no flow is present.

5.3.2 Controllers

The heating system controllers are PID-controllers with settable P-band, I-time and D-time.

5.3.3 Night set-back

The Exigo has individual schedules for each hot water system with two normal-temperature periods per day.

5.3.4 Pump control (HW1 only)

The Exigo has a digital output signal that can be used to control the hot-water circulation pump in HW1. The pump will run according to the settings of the night set-back schedule, running during normal temperature periods and standing still during periods with reduced temperature.

5.3.5 Periodic overheating (HW1 only)

To prevent the growth of Legionella bacteria, the function periodic overheating can be activated. Overheating can take place once a day or once a week. The running time and start time are settable. When using a return temperature sensor, the function will be aborted when the temperature on the return exceeds 55°C. The minimum running time is 4 minutes.

5.3.6 Prioritise domestic hot water (DHW) over heating system (HS)

Exigo contains a function for prioritising the domestic hot water circuits over the heating system circuits. This can be useful when it is very cold outside and the system is somewhat undersized. When one of the DHW circuits falls below the setpoint by a settable amount of degrees for a settable amount of time, the HS circuit actuators will be forced to close.

5.4 Storage tank

A storage tank function, HP1, can be enabled.

The storage tank load pump, P1-HP1 is started depending on the accumulator tank supply water and return water temperatures. The return temperature sensor is placed in the accumulator tank and the supply temperature sensor is placed in the tank inlet.

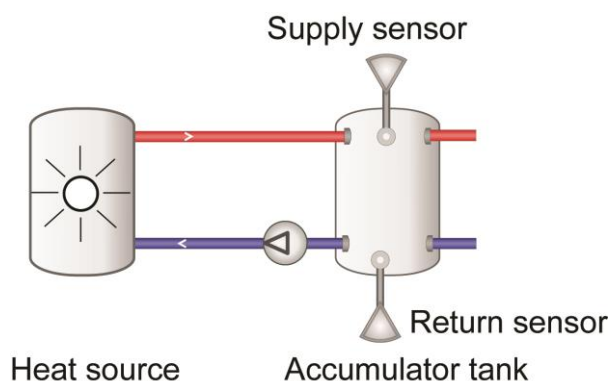

Loading is started if the return water temperature is lower than the set start temperature.

Loading is stopped when the supply temperature is higher than the set stop temperature and the return temperature is higher than the set start temperature + the set differential.

5.5 Boiler control

5.5.1 General

Exigo can be configured for boiler control with 1-4 boilers. Depending on the type of boiler control, the burners of each boiler can be configured as 1-step, 2-step and modulating. The burners are controlled either by a PI-controller with settable P-band and I-time or using a thermostat function.

5.5.2 Type of boiler control

The boiler control can be set as off/on, control via off/on/modulating or as control via modulating.

Off/on control

In this control mode, the burners are controlled using a thermostat function. The burners for each boiler can be configured as 1- or 2-step burners with settable hystereses (Switch difference 1 (SD1) and Switch difference 2 (SD2), respectively) and an offset for step 2 (high output).

Starting and stopping takes place according to the formulas below, see picture for an example:

```
Start low output = SP - SD1
Start high output = SP - SD2 - offset
Stop low output = SP
Stop high output = SP - offset
```

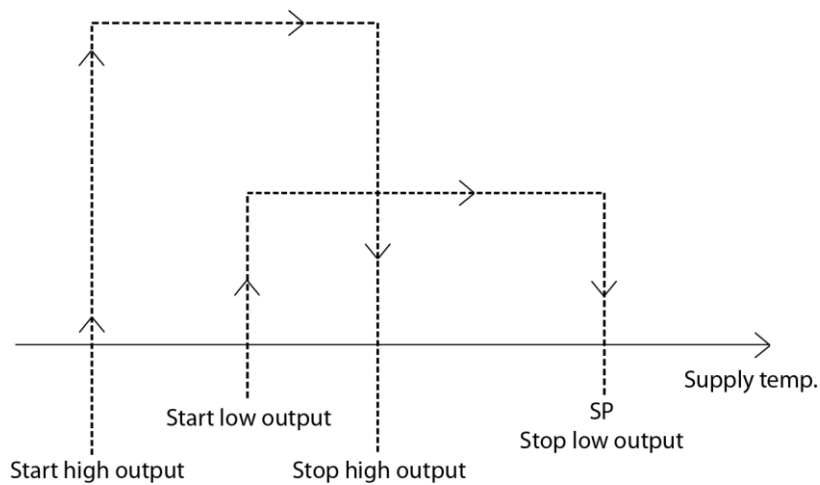

Control using off/on/modulating

When the boiler is set to “Controller with Off/On/Modulating”, the boilers are controlled by a PI-controller with settable P-band and I-time. The initial boiler can either be set to modulating (0...10 V), off/on (1-step) or off/on/high (2-step). Boiler 2-4 can be either 1-step or 2-step.

When boiler 1 is configured as modulating:

Upon a heating requirement increase the analogue output is first controlled 0...10 V. If the heating requirement becomes so great that the first burner is inadequate, the first digital output will be added. The analogue output is kept to 0 V for a settable time period and the controller is blocked. Thereafter, the analogue output will once more be controlled 0...10 V, depending on the heating requirement. A decrease in heating requirement will result in the opposite function (see picture below). The controller will increase/decrease by one step at a time, and each time a digital output is switched on or off the controller will be blocked for the set time period.

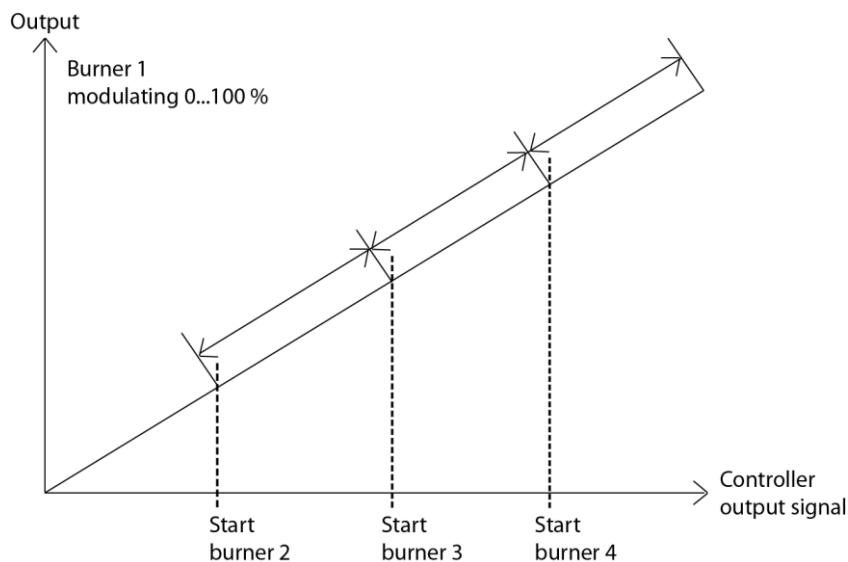

When boiler 1 is configured to a digital function (1-step or 2-step) the digital outputs will step into sequence by one step at a time, and each time a digital output is switched on or off the controller will be blocked for the set time period (see picture below).

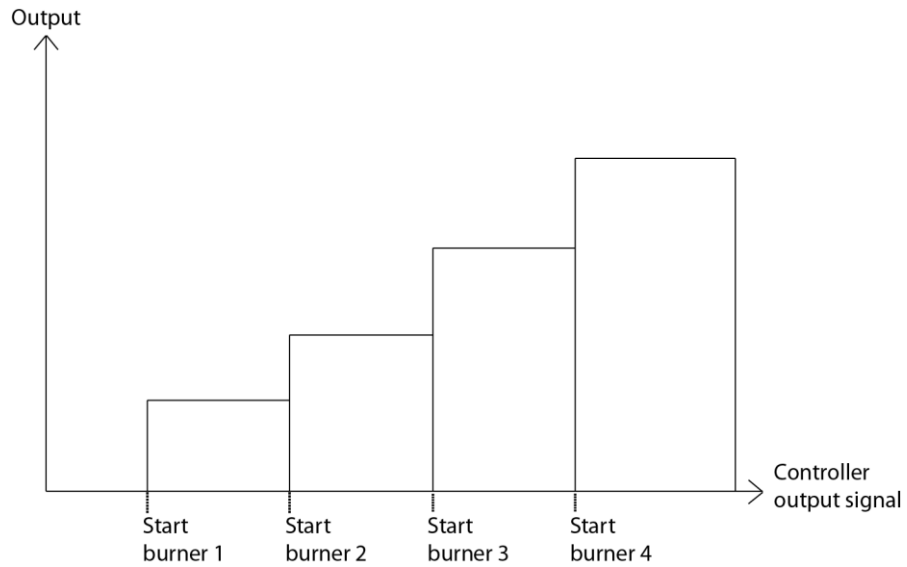

Control using modulating

In this control mode, the burners can only be set as modulating burners (0...10 V). The burners are controlled by a PI-controller with settable P-band and I-time. When there is a heating requirement, the burners are controlled 0...10 V in sequence and each time a digital output is switched on or off the controller will be blocked for the set time period (see picture below).

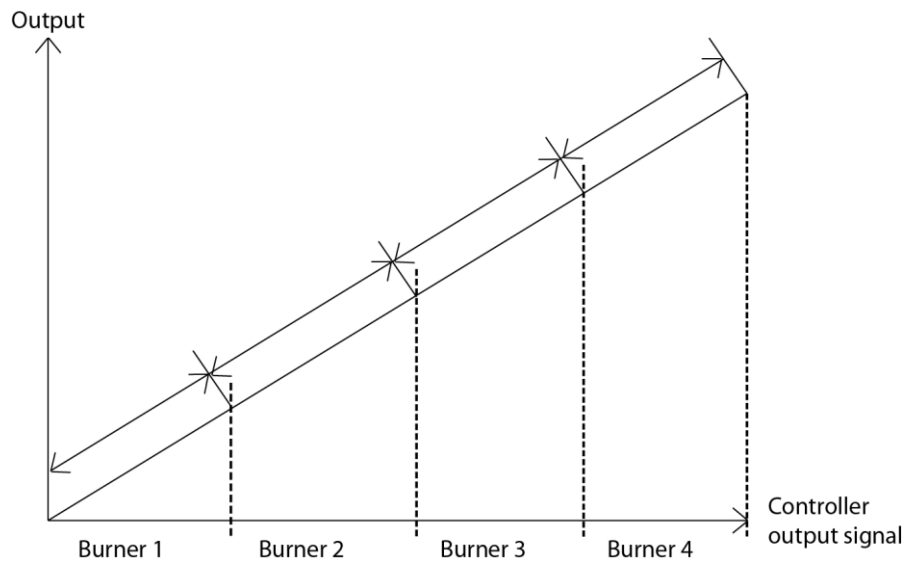

5.6.3 Setpoint

The boiler control setpoint can be configured to one of the following alternatives:

- Constant setpoint = A fixed settable value.
- Circuit-dependent setpoint = Circuit-dependent setpoint can be set to any of the following options:
 1. HS-dependent
 2. HS- and DHW-dependent
 3. HS- and HP1-dependent
 4. HS-, DHW- and HP1-dependent

When a circuit-dependent setpoint has been configured, boiler control setpoint is dependent on the setpoints of other circuits. The circuit whose setpoint is temporarily the highest will, together with an added offset (pre-set to 5 degrees), constitute the boiler control setpoint.

- Outdoor compensated setpoint = The setpoint varies with the outdoor temperature.

Heat demand

Other than the internal setpoint, an analogue input may also be configured to receive a setpoint from another Exigo. The highest setpoint (internal or external) will be used as the relevant setpoint for the boiler.

5.5.4 Minimum run & stop times

The minimum run and stop time for each boiler are individually settable. When the heating requirement increases, the next boiler can start only after the previous boiler has completed its minimum runtime, and when the heating requirement decreases the boiler will not switch off until after its minimum runtime has been completed. A stopped boiler can start again only after it has been switched off for a minimum duration of the set stop time.

These variables are both set to 180 seconds for all boilers.

5.5.5 Starting order

Boiler starting order can be set individually:

- Fixed starting order. The boilers will always start in the same order: Fixed Boiler 1, Fixed Boiler 2, Fixed Boiler 3 and Fixed Boiler 4.
- Runtime-controlled: The boilers will start in order based on shortest runtime.
- Alternating: The start order of the boilers will be changed once per week, alternatively once per day, at a settable time. When changing, the start order will be displaced by one step. I.e.: The boiler which before changing started first will, after changing, start the next boiler, and so on. When the start order is changed, all boilers will shut down and start again if a heating requirement exists.

5.5.6 Boiler exercise

The boilers can be exercised for a settable duration on a settable time and weekday. It is also possible to set the number of weeks between each exercise.

5.5.7 Boiler alarm

If a boiler alarm occurs, the current boiler will be shut down and the next boiler in the start order will start up instead.

5.5.8 Boiler pump

Each boiler has an individual circulation pump. When there is a heating requirement, and before a burner can start, its circulation pump will start up and run for 30 seconds (settable), after which the burner will be permitted to start. When stopping, the burner will stop first, after which the pump will stop after a set shutdown delay.

Pumps are exercised for 5 minutes at 3 pm daily.

5.5.9 Transport pump

The boiler control has a common transport pump. It can be configured either as a single pump (pump A) or as a double pump (pump A and pump B). The pump will start when a burner is active, or if the outdoor temperature drops beneath 18°C (settable). Should an alarm occur in the transport pump, all burners will stop and remain blocked until the alarm has been reset and acknowledged. If the system has been configured as a double pump, it will automatically switch from transport pump A to transport pump B and vice versa, should an alarm occur.

It is also possible to use a digital input for pressure/flow indication. When the transport pump is running, a missing signal will generate an alarm and all boilers will be stopped.

The pump is exercised daily at 3 PM for 5 minutes. If the transport pump has been configured as a double pump, both pumps are exercised.

5.5.10 Boiler return temperature

To minimise the risk of condensation accumulating in the boiler, it is important that the temperature is higher than the condensation temperature. This can be solved in two ways:

Common return temperature

Setting a common return temperature sensor can reduce the risk of condensation. If the temperature at the sensor falls below a settable value (factory setting 30°C), the valves of all HS circuits will be forced to close. The valves will remain closed for as long as the boiler return temperature is lower than the settable value + hysteresis (settable, factory setting 5°C).

Individual return temperatures

Each boiler has a return temperature sensor that controls a mixing valve. If the return temperature falls below a settable temperature (40°C), the mixing valve will be controlled for increased recirculation by a P-controller with settable P-band (10°C).

5.6 Extra circuit

A differential thermostat function to, for instance, load a buffer tank using solar panels. Two analogue inputs are tied to the function (Extra Circuit Sensor 1 and Extra Circuit Sensor 2), as well as a digital output (Extra Circuit Pump). When Extra Circuit Sensor 1 is a settable number of degrees higher (FS=5 degrees) than Extra Circuit Sensor 2, the pump will start. The pump will run until Extra Circuit Sensor 1 = Extra Circuit Sensor 2.

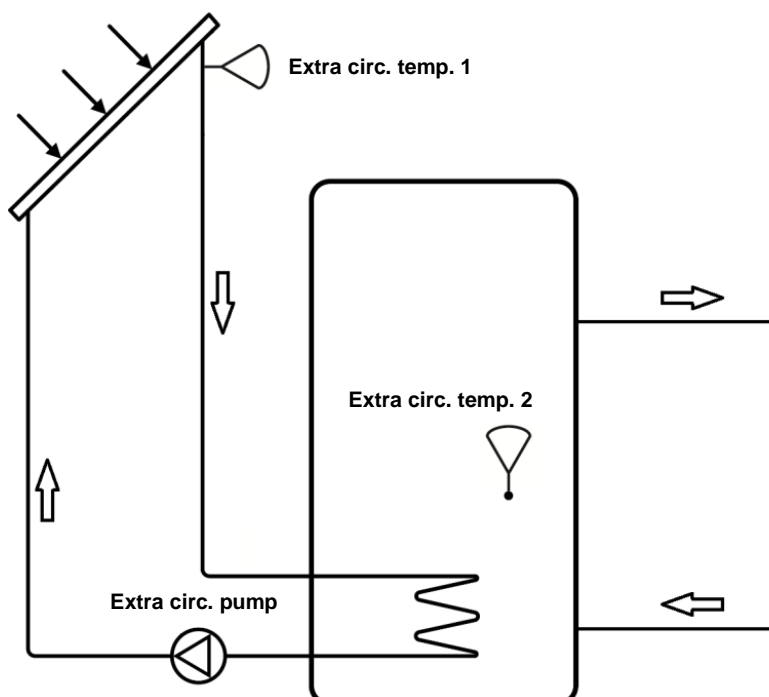

5.7 Cold water monitoring

One or two circuits monitoring the cold-water usage can be configured each using a digital pulse input from a water meter. The pulse constant is settable. Maximum pulse rate is 2 Hz.

5.7.1 Values

The following values are calculated

- 24 hour usage in litres, today
- 24 hour usage in litres, yesterday
- 24 hour usage in litres, day before yesterday
- Lowest hourly usage in litres, today
- Lowest hourly usage in litres, yesterday
- Total usage in m³. The value can be reset.
- Water-flow (litres / min)

5.7.2 Alarms

Pulse error If no pulses are detected within a settable time an alarm is activated. Setting the time to 0 inhibits the alarm function.

High usage If the daily usage is higher than a settable value an alarm is activated.

Leakage control If the lowest hourly usage during the previous day is higher than a settable value an alarm is activated.

5.8 Energy monitoring

One digital pulse function can be configured for monitoring heating energy usage. The pulse constant is settable.

5.8.1 Usage values

The following usage values are calculated:

- 24 hour usage in kWh, today
- 24 hour usage in kWh, yesterday
- 24 hour usage in kWh, day before yesterday
- Total usage in kWh or MWh. The value can be reset.

5.8.2 Power values

Heating power is calculated by measuring the time between energy pulses. The following power values are calculated:

- Instantaneous value for a certain time or after a certain number of pulses.
- Average of the above instantaneous value for the last hour.
- Maximum value for the above instantaneous value.

5.8.3 Leakage monitoring

Once a week the control valves will be closed as energy usage is measured for a preset time. If the energy leakage then exceeds that of a preset value (factory setting 3000 W), an alarm is triggered. The time for and duration of the leakage monitoring is settable. Default is Sundays at 2:00 am for 30 minutes.

5.8.4 Alarms

Pulse error If no pulses are detected within a settable time an alarm is activated. Setting the time to 0 inhibits the alarm function.

High usage If the daily usage is higher than a settable value an alarm is activated.

5.9 Electricity meter

One digital pulse function can be configured for monitoring heating energy usage. The pulse constant is settable.

5.9.1 Usage values

Total usage in MWh. The value can be reset.

5.10 Timer channel outputs

Up to 5 digital outputs can be used as timer controlled outputs. Each with individual week-schedules with two activation periods per day. Each output has 8 separate setting menus, one for each weekday and one extra for holidays. Holiday schedules take precedence over other schedules.

5.11 Alarms

5.11.1 Alarm handling

Current alarms can be viewed by simultaneously pressing the left and up buttons on the front of the Exigo.

Alarms are also indicated by the alarm LED on the external E3-DSP display unit.

All alarms can be monitored, acknowledged and blocked using the display and buttons on the Exigo or E3-DSP. There is also a separate digital input for acknowledging all alarms.

5.11.2 Alarm priorities

Alarms can be given different priority levels, A-alarm, B-alarm, C-alarm or not active. There are three digital outputs that can be used as alarm outputs: Sum alarm, Sum alarm A and Sum alarm B/C.

Sum alarm is active when either a A-, B- or C-alarm is active.

Sum alarm A is active when an A-alarm is active.

Sum alarm B/C is active when a B- or C-alarm is active.

5.11.3 Alarm text

The alarm text that should be shown in the display in the event of an alarm can be changed using E tool[®]. For more information, see the E tool[®] manual.

Chapter 6 Display, LEDs and buttons



This section is applicable to Exigo units with display and buttons but also to the hand terminal E3-DSP, which can be connected to Exigo units with or without built-in display and buttons.

6.1 Display

The display has 4 rows of 20 characters each.

It has background illumination. The illumination is normally off, but is activated as soon as a button is pressed. The illumination will be turned off again after a period of inactivity.

6.2 LEDs on E3-DSP (accessory for Exigo)

There are two LEDs on the front: The alarm LED marked with the  symbol. The “write enable” LED marked with the  symbol.

The four LEDs placed next to the upper terminal strip will be described later.

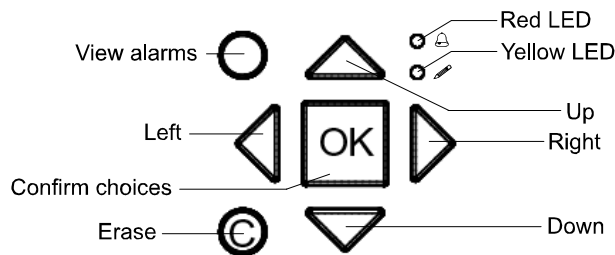

6.3 Buttons

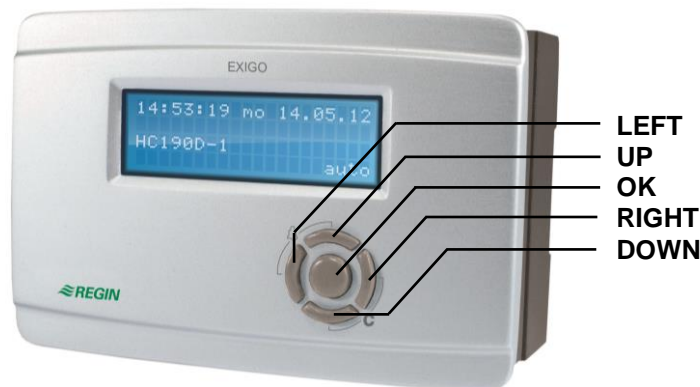

There are five buttons: 4 arrow buttons called UP, DOWN, RIGHT and LEFT. Combinations of LEFT and UP as well as RIGHT and DOWN are also used. The menus in the Exigo are organized in a vertical tree structure. The UP/DOWN buttons are used to move between menus at the present menu level. The RIGHT/LEFT buttons are used to move between menu levels. When changing parameters the UP/DOWN buttons are used to increase/decrease the value of the parameter or to switch between available options. The RIGHT/LEFT buttons to move between digits within the parameter (in units of ones, tens or hundreds).

- The OK button is used to confirm the choice of a parameter setting and to change to “write” mode in menus containing writable values. See more in the section "Change parameters" below.
- To cancel an ongoing selection and return to the original value, the buttons DOWN and RIGHT are pressed simultaneously.
- To view existing alarms press the LEFT and UP buttons simultaneously.

6.4 Navigating the menus

As of version 3.0, significant changes have been made to the Exigo menu system in order to make it more structured and user-friendly. Which menus are shown depends on the choice of access level/user access and the configured inputs/outputs.

The start display, the display normally shown, is at the root of the menu tree.

```

Heating controller
2015:01:08 15:29
HS1
Sp: 52.0   Act: 52.5

```

Pressing DOWN ↓ will move you through the menu options at this, the lowest level. UP ↑ will move you back through the same menus. With normal access and standard configuration, the following menu is shown:

```

HS1
HS2
HW1
Time/Extra timers
Holidays
Energy/Cold water
Running mode
Access rights

```

To enter a higher menu level, use UP or DOWN to place the display marker opposite the menu you wish to access and press RIGHT ➡. At each level there may be several new menus through which you may move using the UP and DOWN buttons.

Sometimes, there are further submenus linked to a menu or menu item. This is indicated by an arrow symbol at the right-hand edge of the display. To choose one, use RIGHT again. To back down to a lower menu level, use LEFT.

Change parameters

Some menus contain parameters that can be set. To change a parameter, first press the OK button. A cursor will appear at the first settable value. If you wish to change the value, do so by pressing the UP and DOWN buttons.

In numbers containing several digits, you can move between the digits (ones, tens or hundreds) by using the LEFT/RIGHT-buttons.

When the desired value is displayed, press OK to confirm it.

If there are further settable values displayed, the cursor will automatically move to the next one.

To pass a value without changing it, press OK.

To abort a change and return to the initial setting, press and hold the DOWN and RIGHT until the cursor disappears.

Chapter 7 Logging on

Exigo has four different access levels: The “Admin” level has the highest access, while the “Service”, “Operator” and basic “Normal” level has the lowest. The choice of access level determines which menus are shown, as well as which parameters can be changed in the displayed menus.

Admin level gives full read/write access to all settings and parameters in all menus.

Service level gives access to all menus except the submenus "Configuration"/"In- and Outputs" and "Configuration"/"System".

Operator level gives access to all menus except "Configuration".

The basic level only permits changes in "Running mode" and gives read-only access to a limited number of menus.

Repeatedly press the DOWN button when the start-up display is shown until the arrow-marker to the left of the text-list points to "Access rights". Press RIGHT.

```
Log on
Log off
Change password
```

7.1 Log on

```
Log on
Enter password:****
Actual level:
None
```

In this menu, it is possible to log on to any access level by entering the appropriate 4-digit code.

The log on-menu will also be displayed should you try to gain access to a menu or try to do an operation requiring higher authority than you have.

Press the OK button and a cursor marker will appear at the first digit position. Repeatedly press the UP button until the correct digit is displayed. Press the RIGHT button to move to the next position. Repeat the procedure until all four digits are displayed. Then press OK to confirm. After a short while the text on the “Present level” line will change to display the new log on level. Press the LEFT button to leave the menu.

7.2 Log off

Use this menu to log off from the present level to the Normal access level.

```
Log off?
No
Actual level:
Admin
```

Automatic logoff

If the access level is Operator, Service or Admin, the user will automatically be logged off to Normal after a settable time of inactivity. See also the section "Automatic logoff". It is possible to set the controller to disable the automatic logoff, see 7.5 below.

7.3 Change password

As default Exigo comes with the following passwords for the different levels:

Admin	1111
Service	2222
Operator	3333
Normal	5555

You can only change the password for access levels lower or equal to the presently active level, i.e. if you are logged in as Admin you can change all passwords, but as Operator you can only change the Operator and Normal passwords. There is no point in changing the “Normal” password since access to that level is granted automatically to all users.

```
Change password for
level:Operator
New password: ****
```

NOTE: Do not set the password for Admin to the same value as the password for a lower level, since this will prevent access to the Admin level.

Forgotten your password? If the password for Admin has been changed and then lost, a temporary password can be obtained from Regin. This code is date dependent and valid for one day only.

7.5 Change password to remove automatic logoff

If you want to remove the automatic logoff, simply change the password of the desired level. The code is changed to 0000, after which the relevant level will always be activated.

NOTE: This should be done with consideration, since no alarm is continuously given that a certain level has been activated. However, it is very useful in certain cases if the unit is intended to be used by trained personnel or, for instance, during commissioning.

Chapter 8 Configuration

Start by logging on as Admin. See chapter 7.

Using DOWN, set the display marker opposite the "Configuration" menu and press RIGHT.

The main configuration menu will be shown.

```
Alarm settings
Inputs/Outputs
Sensor settings
Supply
Return temp
Boiler control
Pump stop
Twin/Single pump
Run ind/Motor prot
Actuator type
Actuator run time
Actuator exercise
Leakage monitoring
Pulse inputs
Alarm config
Communication
Other parameters
System
```

8.1 Alarm settings

```
Alarm limits      →
Alarm delay      →
```

8.1.1 Alarm limits

Control deviation HS1, HS2 and HS3

```
Control deviation
HS1: 20.0 °C
HS2: 20.0 °C
HS3: 20.0 °C
```

Control deviation CS1, HW1 and HW2

```
Control deviation
CS1: 20.0 °C
HW1: 20.0 °C
HW2: 20.0 °C
```

Scalding limit HW1 and HW2

```
Scalding
HW1: 65.0 °C
HW2: 65.0 °C
```

Low return temperature

```
Low return temp  
HW1: 10 °C
```

Boiler limits

```
High boiler temp  
70.0 °C  
Low boiler temp  
30.0 °C
```

High water usage

```
High 24h water  
consump: 10000.0 l  
High 1h water  
consump: 10000.0 l
```

High energy usage

```
High 24h energy  
consump 10000.0 kWh
```

Maximum time between pulses

```
Max between Vpulse  
0 min  
Max between Epulse  
0 min
```

```
Max betw CW1pulse  
0 min  
Max betw CW2pulse  
0 min
```

Maximum permitted leakage

```
Permitted leakage  
3.00 kW
```

8.1.2 Alarm delays

Control deviation HS1, HS2 and HS3

```
Control deviation  
HS1: 60 min  
HS2: 60 min  
HS3: 60 min
```

Control deviation CS1, HW1 and HW2

```
Control deviation  
CS1: 0 min  
HW1: 60 min  
HW2: 60 min
```

Scalding limit

```
Scalding  
HW1: 300 s  
HW2: 300 s
```

Low return temperature

```
Low return temp  
HW1: 20 s
```

Boiler limits

```
High boiler temp  
0 s  
Low boiler temp  
0 s
```

Expansion vessel / External alarm

```
Expansion vessel  
60 s  
External alarm 1  
0 s
```

8.2 Inputs and outputs

```
AI  
DI  
UI  
AO  
DO
```

General

Free configuration

Any control signal can be bound to any input/output, the only restriction being that digital signals cannot be bound to analogue inputs and vice versa. It is up to the user doing the binding to make sure that activated functions are bound to appropriate signals.

Delivery setting

On delivery all the physical inputs and outputs have already been bound to a signal.

The delivery settings are intended as suggestions only and can be changed freely.

8.2.1 Analogue inputs AI

```
AI1  
Sign: Outd temp  
Raw value: 22.3  
Compensation:0.0°C
```

All analogue inputs are for PT1000.

Input signals can be compensated, e.g. for wiring resistance.

The raw value will show the actual, uncompensated input value.

8.2.2 Digital inputs DI

```
DI1  
NO/NC: NO Signal:  
HS1 pumpA  
Status: No
```

To simplify adaptation to external functions, all digital inputs can be configured to be either normally open, NO, or normally closed, NC.

The inputs are as standard normally open, i. e. if the input is closed, the function connected to the input in Exigo is activated.

8.2.3 Universal inputs UI

These can individually be configured as either analogue inputs or as digital inputs. When configured as analogue inputs they can be bound to any of the analogue signals described under Analogue signals.

When configured as digital inputs they can be bound to any of the digital signals described under Digital signals.

```
UI1 →  
Choose AI or DI sign  
AI sign: HS2 supply  
DI sign: Not active
```

After having selected AI or DI (the unused alternative must be set to *not active*), a sub menu is available, containing settings for when the input is configured as an AI input. This menu is accessed by pressing RIGHT.

```
UAI1  
Sign: HS2 supply  
Raw value: 38.5  
Compensation: 0.0 °C
```

Input signals can be compensated, e.g. for wiring resistance.

The raw value will show the actual, uncompensated input value.

If the input is configured as a digital input, a submenu is available which is accessed by pressing RIGHT:

```
UDI1  
NO/NC: NO Signal:  
HS2 pumpA  
Status: No
```

To simplify adaptation to external functions, all universal inputs configured as digital inputs can be set to be either normally open, NO, or normally closed, NC.

The inputs are as standard normally open, i. e. if the input is closed, the function connected to the input in Exigo is activated.

8.2.4 Analogue outputs

Analogue outputs are 0...10 V DC.

```
AO1  
Sign: HS1 actuator  
Auto  
Value: 2.3 V
```

By pressing the OK button three times (until Auto is blinking) the output can be set to Auto, Manual or Off. In Auto mode, the output is controlled by the Exigo. In Manual mode, the output can be controlled manually by pressing DOWN until reaching Value and then setting the output to 0...10 V. In Off mode, the output signal will always be 0 V.

8.2.5 Digital outputs

```
DO1  
Signals: HS1 pumpA  
Auto  
Status: On
```

Digital outputs can be set to one of three modes: Auto, Manual Off or Manual On.

8.3 Sensor settings

This menu permits setting which sensor type is connected: PT1000 or External sensor.

The room temperature of the HS circuits can be received via communication by activating the EcoGuard function and connecting the sensor to a communication port (the port must then also be set). It is then also necessary to set the room sensor to “External sensor”.

```
HS1 room sensor
Type:PT1000
```

The HS circuits can receive the room temperature via EXOline communication:

```
HS1 room sensor
Type:External sensor
```

After an external sensor has been activated, it is also necessary to set which circuit should be affected by the function:

```
External sensor
None
```

8.4 Supply

```
Parallel displ
Max limit sp
Min limit sp
Auto-correct setp
Wind compensation
Optimizer
Power limit M-Bus
Control function
Heat demand to AO
```

8.4.1 Parallel displacement

A parallel displacement can be added to each of the set control curves.

```
Parallel displ
HS1: 0.0 °C
HS2: 0.0 °C
HS3: 0.0 °C
CS1: 0.0 °C
```

8.4.2 Maximum limit

A maximum supply temperature can be set individually for each system.

```
Max limit sp
HS1: 1000°C
HS2: 1000°C
HS3: 1000°C
CS1: 1000°C
```

8.4.3 Minimum limit

A minimum supply temperature can be set individually for each system.

```
Min limit sp
HS1: 0 °C
HS2: 0 °C
HS3: 0 °C
```

8.4.4 Auto-correction of setpoint

Room sensors can be used to correct the set control curves. The average temperature over a period of time is calculated and will parallel displace the entire curve up or down, depending on whether the difference between the room setpoint and actual room temperature is negative or positive. After the comparison, the deviation is multiplied by the correction factor and the sum is added to the present displacement according to the following formula:

```
Displacement = (Room setpoint - Average temp)*Factor
```

The frequency of this calculation can be set between 0...24 h. At 0 h, a calculation is made every minute and at 24 h a calculation is made once every day. The correction factor is adjustable 0...100. The current displacement has minimum/maximum limits of $\pm 6^{\circ}\text{C}$. The current room temperature must be between 10...30°C for the function to activate, and the outdoor temperature must be in between the X coordinates on the outdoor compensated curve (i.e. outdoor temperature FS - 20...+15°C).

```
Auto-correction
setpoint HS1
On →
```

```
Corr factor HS1
2.0
Present correction
0.6°C
```

```
Correction time
(0=directly): 1 h
```

The lower the correction time, the lower the correction factor should be. If the correction factor is set too high in relation to the time, the present correction will change very quickly.

The room sensor values can also be received via an EcoGuard unit, if one is used.

8.4.5 Optimisation

When comfort control is activated after a period of economy mode, the optimizer function is utilised in order to reach comfort temperature. For more information, see section 5.1.10.

```
Optimizer function
Min capacity
Max capacity
Outdoor comp fact
```

8.4.5.1 Optimizer function

Activation or deactivation of the function.

```
Optimizer function
HS1: Off
HS2: Off
HS3: Off
```

8.4.5.2 Minimum capacity

Setting of the minimum value of the capacity variable.

```
Min capacity
HS1: 0.02 °C/min
HS2: 0.02 °C/min
HS3: 0.02 °C/min
```

8.4.5.3 Maximum capacity

Setting of the maximum value of the capacity variable.

```
Max capacity
HS1: 0.10 °C/min
HS2: 0.10 °C/min
HS3: 0.10 °C/min
```

8.4.5.4 Outdoor compensation factor

Setting of the outdoor temperature effect on the function.

```
Outdoor comp fact
HS1: 3.0 %
HS2: 3.0 %
HS3: 3.0 %
```

8.4.6 Power limitation M-Bus

By connecting a district heating meter via the RS485 port, the power to HS1 can be restricted. Then the control valve is controlled by two PI units and the one with the lowest output signal will be controlling the valve. An X1176 interface converter is required for this measurement.

```
Power limit M-Bus
HS1: On
```

8.4.7 Control function CS1

The setpoint for the cooling circuit can be either constant or outdoor compensated.

```
Control function CS1
Constant setpoint
```

8.5 Return temperature limits

Individual maximum and minimum temperature limits can be set for the different temperature systems. If the return temperature is not within the set limits, the supply temperature will be adjusted to eliminate the error. The adjustment will be the temperature offset multiplied by the set limiting factor.

```
Max return temp
Max delta-T HP/HS
Min return temp
Return limit factor
```

8.5.1 Maximum temperature, return

```
Max return temp
HS1:Active      →
HS2:Not active
HS3:Not active
CS1:Not active
```

```
Max return temp
HS1: 1000 °C
HS2: 1000 °C
HS3: 1000 °C
CS1: 1000 °C
```

8.5.2 Max Delta-T HP/HS

The return temperature on heating primary can be limited so that HP primary is not allowed to exceed the return on the secondary circuit by more than 3 degrees (adjustable). When this function is active and heating primary exceeds the secondary circuit return by more than the set number of degrees, the valve will close in order to lower the return temperature.

```
Max delta-T HP/HS
HS1:Active      →
HS2:Not active
```

```
Max delta-T HP/HS
HS1: 3 °C
HS2: 3 °C
```

8.5.3 Minimum temperature, return

```
Min return temp
HS1:Active      →
HS2:Not active
HS3:Not active
CS1:Not active
```

```
Min return temp
HS1: 0 °C
HS2: 0 °C
HS3: 0 °C
CS1: 0 °C
```

8.5.4 Limiting factor, return limitation

```
Return limit factor
HS1: 1.00
HS2: 1.00
HS3: 1.00
CS1: 1.00
```

8.6 Boiler control

For configuring and setting the boiler control.

```
General
Boiler1
Boiler2
Boiler3
Boiler4
Boiler pumps
```

8.6.1 General

Boiler control type setting. Boiler control can be set to either “Off/on”, “Control via off/on/modulating” or as “Control via modulating”. For more information on the different settings, see section 5.6.2.

```
Type of boiler ctrl
Off/on
```

When boiler control is set to either “Control via off/on/modulating” or “Control via modulating”, boiler exchange can be activated. For individual boiler settings, see section 8.5.2.

```
Boiler exchange
Weekday: No exchange
Hour: 10
```

”Type of Setpoint” can be set as ”Constant setpoint”, ”Outdoor compensated setpoint” or ”Circuit-dependent setpoint”. See section 5.6.3 for more information.

```
Type of setpoint
Constant setpoint
```

The number of boilers can be set to 1-4.

```
Number of boilers
4
```

If the common return temperature sensor “Boiler return temp” falls below the set temperature, HS valve output will be blocked. The block is removed once the return temperature has risen above the set temperature +5°C.

```
Block valves
at low boiler return
temp: 30.0 °C
Hyst: 5.0 °C
```

8.6.2 Boiler 1-4

The boilers can have 1-step, 2-step or modulating burners.

```
Vessel1
1-step
```

For setting the start order and minimum permitted runtime and stop time. The start order can be set to ”Fixed 1-4 Boiler”, runtime-controlled or alternating. See section 5.6.5 for more information.

```
Start mode:  
Fixed 1st boiler  
Min run time: 180 s  
Min stop time: 180 s
```

When using a modulating burner, the control signal can be 0...10 V, 2...10 V, 10...2 V or 10...0 V.

```
Vessel1  
Control signal:0-10V
```

Boiler exercise settings:

```
Exercise:Off  
No of weeks:4  
Day: Sun Hour: 15  
Exercise time: 5 min
```

8.6.3 Pumps

The boiler control has a common transport pump (single or double). There is also an individual boiler pump for each boiler.

```
Transport pump  
Boiler pump(s)
```

The common transport pump will start and stop partly based on outdoor temperature and partly based on demand. If the outdoor temperature is below 18°C, the pump will run continuously. If the outdoor temperature is above 18°C, the pump will start if there is a heating requirement, i.e. when one of the boilers are active.

```
Outd temp for start  
of pump: 18 °C  
Hyst for start/stop  
of pump: 1.0 °C
```

Before the boiler can start, its circulation pump must first run for 30 seconds. When stopping, the boiler will stop first and the pump will follow after an additional 30 seconds.

```
Run time before  
start of HB: 30 s  
Run time after stop  
of HB: 30 s
```

For setting the pump exercise. To deactivate exercising, "Hour" is set to 0.

```
Pump exercise  
Hour: 15  
Time: 5 min
```

8.7 Pump stop

Each heating system has individual start and stop delays. If the outdoor temperature exceeds the set stop temperature for longer than the set stop delay, the circulation pump will stop and output to the valve actuator is set to 0. The pump will start again if the outdoor temperature falls below the set stop temperature with more than the set hysteresis for longer than the start delay. For information on how to set the hysteresis, as well as the start and stop temperatures, see section 9.1.1.

```
Pump stop HS1:On  
Stop delay: 1 min  
Start delay: 0 min
```

The cooling system also has individual start and stop delays. If the outdoor temperature falls below the set stop temperature for longer than the set stop delay, the pump will stop and output to the valve actuator is set to 0. The pump will start again if the outdoor temperature exceeds the set start temperature with more than the set hysteresis for longer than the start delay. For information on how to set the hysteresis, as well as the start and stop temperatures, see section 9.1.2.

As an alternative to outdoor temperature dependent pump stop, the digital input "CS1 start" can be used for stopping/starting the pump and control. The output to the valve actuator will then be forced to 0 V when the input is off. If CS1 start has been configured, this input must be active for the pump to be allowed to start again and the valve to open when needed. This function can prove useful when wishing to manually effect the starting and stopping of the cooling system.

```
Pump stop HS1:On  
Stop delay: 1 min  
Start delay: 1 min
```

The domestic hot water system HW1 does not have any temperatures for pump stop, but follows the timer output instead. HW1 stops when the timer is outside the time channel for comfort temperature. The pump will start again once the timer is within the configured comfort period.

```
Pump stop HW1:Off
```

Daily pump exercise of the heating systems and the cooling system takes place daily at 15:00 (settable).

```
Hour for exercise  
HS1: 15 h  
HS2: 15 h  
HS3: 15 h
```

```
Hour for exercise  
CS1: 15 h
```

8.8 Twin/Single pump

Each system can be configured for either a single pump or twin pumps.

The pumps are run one at a time, with automatic alternation weekly on Tuesdays at 10:00 AM. If the pump alarm for the active pump is activated, the Exigo will automatically switch to the other pump.

```
Twin/Single pump  
HS1: Twin pumps  
HS2: Single pump  
HS3: Single pump
```

```
Twin/Single pump  
CS1: Single pump  
Transp p: Single pump
```

8.9 Run indication/Motor protection

Digital inputs can be used either for indication of the motor running or for monitoring of motor protection contacts for pumps. The inputs can be normally open (NO) or normally closed (NC) (see section 8.2.2.). When the pump is configured to run indication, the input should be NO and, consequently, the digital input should be on when the pump is running and off when the pump is at a standstill. An alarm is generated if this is not the case for longer than the set alarm delay for the pump in question.

If the pump is configured to motor protection and the input is set to NO, a pump alarm is generated when the input is on. If the input is NC, the pump alarm will be generated if the input is off.

```
Run ind/Motor prot
HS1: Motor prot
HS2: Motor prot
HS3: Motor prot
```

```
Run ind/Motor prot
CS1: Motor prot
Ext circ:Motor prot
```

```
Run ind/Motor prot
HW1: Motor prot
HP1: Motor prot
Freq con: Motor prot
```

```
Boiler1: Motor prot
Boiler2: Motor prot
Boiler3: Motor prot
Boiler4: Motor prot
```

```
HB pump1: Motor prot
HB pump2: Motor prot
HB pump3: Motor prot
HB pump4: Motor prot
```

```
Transp pump:Motor prot
```

8.10 Actuator type

Choose output signals to the actuators connected to the analogue control outputs: 0...10 V DC, 2...10 V DC, 10...0 V DC or 10...2 V DC.

```
Actuator type
HS1: 0-10V
HS2: 0-10V
HS3: 0-10V
```

```
Actuator type
CS1: 0-10V
```

```
Actuator type
HW1: 0-10V
HW2: 0-10V
Freq: 0-10V
```

NOTE: Although many manufacturers state 0...10 V DC as control signal, for many actuators the actual control signal is more often than not 2...10 V DC. Check the instruction for the actuator carefully! If uncertain, choose 0...10 V DC. Although control might be less accurate, it will ensure that the valve always can be driven to its fully opened and fully closed positions.

8.11 Running time, 3-position actuators

These parameters have no function if analogue actuators are configured.

The values are used to determine the control parameters for 3-position actuators.

It is important to set values correctly since improper values will lead to control inaccuracies.

```
Actuator run time
HS1: 120 s
HS2: 120 s
HS3: 120 s
```

```
Actuator run time
CS1: 120 s
HW1: 80 s
HW2: 80 s
```

8.12 Valve exercise

The valves and actuators for the cooling and heating systems can be exercised daily. Default time is 2:00 PM, but the time can be changed freely. The actuators will be forced to the open position for the set time (factory setting 15 seconds, can be changed via E tool[®]). The pumps will run and the temperature offset alarm will be blocked for the duration of the exercising.

```
Actuator exercise
HS1: Off      Time:15 s
Day: Every day
Hour:2       Min: 0
```

```
Actuator exercise
CS1: Off      Time:15 s
Day: Every day
Hour:2       Min: 0
```

8.13 Leakage monitoring

Once a week the control valves will be closed as energy usage is measured for a preset time. If the energy leakage then exceeds that of a preset value (factory setting 3000 W), an alarm is triggered. The time for and duration of the leakage monitoring is settable. Default is Sundays at 2:00 AM for 30 minutes.

```
Leakage monitoring:Off
Weekday:Sunday
Hour: 2
Duration: 30 min
```

```
Permitted leakage
3.00 kW
Start monitoring now
No
```

8.14 Pulse inputs

```
Energy pulse heating
100.0 kWh/pulse
Volume pulse heating
10.0 l/pulse
```

```
Cold water1
10.0 l/pulse
Cold water2
10.0 l/pulse
```

```
Electricity meter
100.0 kWh/pulse
```

8.15 Alarm configuration

Permits configuration of all alarms.

Select the appropriate alarm number from the alarm list below. The alarm text for the alarm will be displayed and the alarm priority can be set; A-alarm, B-alarm, C-alarm, or Not active.

```
Alarm no(1-149): 1
Malfunction P1A-HS1
→
```

```
Malfunction P1A-HS1
Priority:B-alarm
```

Alarm text

The alarm text that should be shown in the display in the event of an alarm can be changed using E tool[®]. For more information, see the E tool[®] manual.

Alarm list

The alarm text and priority columns show the factory set values.

	Alarm text	Prio	Description
1	Malfunction P1A-HS1	B	Malfunction pump P1A-HS1
2	Malfunction P1B-HS1	B	Malfunction pump P1B-HS1
3	Malfunction P1A-HS2	B	Malfunction pump P1A-HS2
4	Malfunction P1B-HS2	B	Malfunction pump P1B-HS2
5	Malfunction P1A-HS3	B	Malfunction pump P1A-HS3
6	Malfunction P1B-HS3	B	Malfunction pump P1B-HS3
7	Malfunction P1-HW1	B	Malfunction pump P1-HWC
8	Malfunction P1-HP1	B	Malfunction pump P1-HP1
9	Malfunction frequency converter	B	Malfunction frequency converter
10	Expansion vessel	A	Malfunction expansion vessel
11	External alarm	A	External alarm 1

	Alarm text	Prio	Description
12	Boiler alarm	A	Boiler alarm
13	Deviation HS1	A	Supply Temp. HS1 deviates too much from the setpoint for too long
14	Deviation HS2	A	Supply temp. HS2 deviates too much from the setpoint for too long
15	Deviation HS3	A	Supply temp. HS3 deviates too much from the setpoint for too long
16	Deviation HW1	A	Supply temp. HW1 deviates too much from the setpoint for too long
17	Deviation HW2	A	Supply temp. HW2 deviates too much from the setpoint for too long
18	Sensor error outdoor temp	B	Sensor error outdoor temp
19	High HW1 temp	B	HW1 supply temperature too high
20	High HW2 temp	B	HW2 supply temperature too high
21	High boiler temp	A	Boiler temperature is too high
22	Low boiler temp	A	Boiler temperature is too low
23	Pulse error volume	B	No pulses from water volume meter
24	Pulse error energy	B	No pulses from energy meter
25	High cold water consumption/day	B	24 hour cold water usage higher than limit
26	High energy usage	B	24 hour energy usage higher than set limit
27	High cold water consumption/h	B	Cold water usage/hour higher than set limit
28	High leakage	B	Leakage higher than set value
29	Malfunction P1A&B-HS1	A	Malfunction both circulation pumps P1A and P1B in HS1
30	Malfunction P1A&B-HS2	A	Malfunction both circulation pumps P1A and P1B in HS2
31	Malfunction P1A&B-HS3	A	Malfunction both circulation pumps P1A and P1B in HS3
32	Pulse error CW1	B	No pulses from cold water meter 1
33	Pulse error CW2	B	No pulses from cold water meter 2
34	HS1 manual	C	HS1 in manual running mode
35	HS2 manual	C	HS2 in manual running mode
36	HS3 manual	C	HS3 in manual running mode
37	HW1 manual	C	HW1 in manual running mode
38	HW2 manual	C	HW2 in manual running mode
39	Pressure manual	C	Pressure control in manual running mode
40	Boiler manual	C	Boiler in manual running mode
41	P1A-HS1 manual	C	P1A-HS1 in manual running mode
42	P1B-HS1 manual	C	P1B-HS1 in manual running mode
43	P1A-HS2 manual	C	P1A-HS2 in manual running mode
44	P1B-HS2 manual	C	P1B-HS2 in manual running mode
45	P1A-HS3 manual	C	P1A-HS3 in manual running mode
46	P1B-HS3 manual	C	P1B-HS3 in manual running mode
47	P1-HW1 manual	C	P1-HW1 in manual running mode

	Alarm text	Prio	Description
48	P1-HP1 manual	C	P1-HP1 in manual running mode
49	P1-frequency manual	C	P1 Frequency converter in manual running mode
50	HS1 supply max	-	HS1 supply temp. max. limitation activated
51	HS2 supply max	-	HS2 supply temp. max. limitation activated
52	HS3 supply max	-	HS3 supply temp. max. limitation activated
53	HS1 supply min	-	HS1 supply temp. min. limitation activated
54	HS2 supply min	-	HS2 supply temp. min. limitation activated
55	HS3 supply min	-	HS3 supply temp. min. limitation activated
56	HS1 return max	-	HS1 return temp. max. limitation activated
57	HS1 return max	-	HS2 return temp. max. limitation activated
58	HS1 return max	-	HS3 return temp. max. limitation activated
59	HS1 return min	-	HS1 return temp. min. limitation activated
60	HS2 return min	-	HS2 return temp. min. limitation activated
61	HS3 return min	-	HS3 return temp. min. limitation activated
62	HS1 frost	B	HS1 frost protection active
63	HS2 frost	B	HS2 frost protection active
64	HS3 frost	B	HS3 frost protection active
65	Internal battery error	B	Internal battery needs replacing
66	Low boiler return temp	C	Return temperature from boiler is too low
67	Sensor error HS1 supply	B	Power failure or short-circuit sensor HS1 supply
68	Sensor error HS2 supply	B	Power failure or short-circuit sensor HS2 supply
69	Sensor error HS3 supply	B	Power failure or short-circuit sensor HS3 supply
70	Sensor error HW1 supply	B	Power failure or short-circuit sensor HW1 supply
71	Sensor error HW2 supply	B	Power failure or short-circuit sensor HW2 supply
72	Sensor error HP1 supply	B	Power failure or short-circuit sensor HP1 supply
73	Sensor error HS1 room	B	Power failure or short-circuit sensor HS1 room
74	Sensor error HS2 room	B	Power failure or short-circuit sensor HS2 room
75	Sensor error HS3 room	B	Power failure or short-circuit sensor HS3 room
76	Sensor error HS1 return	B	Power failure or short-circuit sensor HS1 return
77	Sensor error HS2 return	B	Power failure or short-circuit sensor HS2 return
78	Sensor error HS3 return	B	Power failure or short-circuit sensor HS3 return
79	Sensor error HP1 return	B	Power failure or short-circuit sensor HP1 return
80	Sensor error wind	B	Power failure or short-circuit wind sensor
81	Sensor error pressure	B	Power failure or short-circuit pressure sensor
82	Sensor error boiler temp	B	Power failure or short-circuit sensor boiler supply
83	Sensor error boiler return	B	Power failure or short-circuit sensor boiler return

	Alarm text	Prio	Description
84	Sensor error CS1 supply	B	Power failure or short-circuit sensor CS1 supply
85	Sensor error CS1 return	B	Power failure or short-circuit sensor CS1 return
86	Sensor error HP supply	B	Power failure or short-circuit sensor HP supply
87	Sensor error HP return	B	Power failure or short-circuit sensor HP return
88	Sensor error CP supply	B	Power failure or short-circuit sensor CP supply
89	Sensor error CP return	B	Power failure or short-circuit sensor CP return
90	Sensor error extra sensor 1	B	Power failure or short-circuit extra sensor 1
91	Sensor error extra sensor 2	B	Power failure or short-circuit extra sensor 2
92	Sensor error extra sensor 3	B	Power failure or short-circuit extra sensor 3
93	Sensor error extra sensor 4	B	Power failure or short-circuit extra sensor 4
94	Sensor error extra sensor 5	B	Power failure or short-circuit extra sensor 5
95	Sensor error boiler supply	C	Power failure or short-circuit, boiler supply sensor
96	Sensor error boiler1 return	B	Power failure or short-circuit, boiler 1 return sensor
97	Sensor error boiler2 return	B	Power failure or short-circuit, boiler 2 return sensor
98	Sensor error boiler3 return	B	Power failure or short-circuit, boiler 3 return sensor
99	Sensor error boiler4 return	B	Power failure or short-circuit, boiler 4 return sensor
100	Sensor error 1 extra circuit	B	Power failure or short-circuit extra circuit 1
101	Sensor error 2 extra circuit	B	Power failure or short-circuit extra circuit 2
102	Sensor error CS1 room PT1000	B	Power failure or short-circuit, CS1 room sensor
103	Sensor error CS1 room 0-10V	B	Power failure or short-circuit,0...10 V room sensor
104	Sensor error HW1 return	B	Power failure or short-circuit, HW1 return sensor
106	Deviation CS1	B	Supply temp. CS1 deviates too much from the setpoint for too long
107	CS1 manual	B	CS1 in manual running mode
108	CS1 supply max	B	CS1 supply temp. max. setpoint limitation activated
109	CS1 supply min	B	CS1 supply temp. min. setpoint limitation activated
110	CS1 return max	B	CS1 return temp. max. limitation activated
111	CS1 return min	B	CS1 return temp. min. limitation activated
112	Malfunction P1A-KS1	B	Malfunction pump P1A-CS1
113	Malfunction P1B-KS1	B	Malfunction pump P1B-CS1

	Alarm text	Prio	Description
114	Malfunction P1A&B-CS1	B	Malfunction both circulation pumps P1A and P1B in CS1
115	P1A-CS1 manual	B	P1A-CS1 in manual running mode
116	P1B-CS1 manual	B	P1B-CS1 in manual running mode
117	Communication error expansion unit 1	B	Communication interrupted between expansion unit 1 and master controller
118	Communication error expansion unit 2	B	Communication interrupted between expansion unit 2 and master controller
119	Communication error M-Bus DHM1	B	M-Bus communication fault between master and district heating meter
120	Communication error M-Bus WM1	B	M-Bus communication fault between master and water meter 1
121	Communication error M-Bus WM2	B	M-Bus communication fault between master and water meter 2
122	Low return temp HW1	B	Return temperature too low for too long
123	Boiler pressure/flow error	B	Pressure or flow error on the boiler circuit
124	Malfunction boiler 1	B	Malfunction in boiler 1
125	Malfunction boiler 2	B	Malfunction in boiler 2
126	Malfunction boiler 3	B	Malfunction in boiler 3
127	Malfunction boiler 4	B	Malfunction in boiler 4
128	Malf boiler pump 1	B	Malfunction in boiler pump 1
129	Malf boiler pump 2	B	Malfunction in boiler pump 2
130	Malf boiler pump 3	B	Malfunction in boiler pump 3
131	Malf boiler pump 4	B	Malfunction in boiler pump 4
132	Malf transport pump A	B	Malfunction boiler transport pump A
133	Boiler 1 manual	C	Boiler 1 in manual mode
134	Boiler 2 manual	C	Boiler 2 in manual mode
135	Boiler 3 manual	C	Boiler 3 in manual mode
136	Boiler 4 manual	C	Boiler 4 in manual mode
137	Boiler pump 1 manual	C	Boiler pump 1 in manual mode
138	Boiler pump 2 manual	C	Boiler pump 2 in manual mode
139	Boiler pump 3 manual	C	Boiler pump 3 in manual mode
140	Boiler pump 4 manual	C	Boiler pump 4 in manual mode
141	Transport pump manual	C	Transport pump in manual mode
142	Malfunction P1-ext circ	B	Malfunction P1-extra circuit
143	P1-ext circ manual	C	Unit P1-extra circuit in manual mode
144	HW1 blocked for HS priority	B	HW1 is blocked for HS priority
145	HW2 blocked for HS priority	B	HW2 is blocked for HS priority
146	HP1 blocked for HS priority	B	HP1 is blocked for HS priority
147	HS1 blocked for HW priority	B	HS1 is blocked for HW priority

	Alarm text	Prio	Description
148	HS2 blocked for HW priority	B	HS2 is blocked for HW priority
149	HS3 blocked for HW priority	B	HS3 is blocked for HW priority
150	Malf transport pump B	B	Malfunction in boiler transport pump B
151	Transport pump B manual	C	Transport pump B in manual mode
152	Sensor error outdoor temp HS2	B	Power failure or short-circuit, outdoor temp. sensor HS2
153	Sensor error outdoor temp HS3	B	Power failure or short-circuit, outdoor temp. sensor HS3
154	Sensor error boiler 1 supply	B	Power failure or short-circuit, boiler 1 supply sensor
155	Sensor error boiler 2 supply	B	Power failure or short-circuit, boiler 2 supply sensor
156	Sensor error boiler 3 supply	B	Power failure or short-circuit, boiler 3 supply sensor
157	Sensor error boiler 4 supply	B	Power failure or short-circuit, boiler 4 supply sensor
158	Boiler 1 high supply temp	B	High supply temperature, boiler 1
159	Boiler 2 high supply temp	B	High supply temperature, boiler 2
160	Boiler 3 high supply temp	B	High supply temperature, boiler 3
161	Boiler 4 high supply temp	B	High supply temperature, boiler 4

8.16 Communication

8.16.1 TCP/IP

DHCP

Dynamic Host Configuration Protocol (DHCP) is a network protocol used in Internet Protocol (IP) networks for dynamic distribution of network configuration parameters, including IP addresses, DNS server and other services. Exigo can either be configured to obtain an IP address from a DHCP server (dynamic) or an address can be set manually (static).

If wishing to set a static IP address for Exigo, it is only necessary to enter the desired IP address together with a subnet mask, gateway address and a DNS server address.

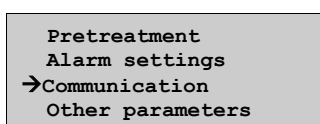

```
DHCP: Yes
Set static IP →
Current IP
10.0.0.190
```

```
IP
192.168.001.234
Subnet mask
255.255.255.000
```

```
Current subnet mask
-
Current gateway
-
```

```
Default gateway
192.168.001.001
DNS
192.168.001.001
```

```
Current DNS
10.0.0.200
```

8.16.2 Modbus communication

Exigo can be connected to a network for Modbus communication..

Modbus communication is possible either via the serial RS485 port or via TCP/IP.

The serial port (RS485) can be set either to Slave or Expansion units/External sensor or to M-Bus; however, the latter option requires special hardware (see below). When the port is configured as a slave, the Exigo is set to communicate via EXOline or Modbus.

```
Function port1 →
Slave
```

Press the RIGHT arrow key to activate Modbus:

```
Modbus
communication
Slave port1
Not active
```

If Modbus communication is activated, settings can be made by pressing the RIGHT arrow key.

```
Modbus address: 1
Speed:9600 bps
Two stop bits: No
Parity: None
```

NOTE: Only one stop bit can be used.

When the function is set to “Expansion units/External sensor”, it is possible to connect up to two expansion units as well as an external “EcoGuard” model unit (see section 5.1.3.1). The expansion controllers must have the addresses 241:1 and 241:2 respectively (ELA:PLA).

```
Expansion unit 1
None
Expansion unit 2
None
```

The EcoGuard unit must be configured with PLA:241 ELA:200. “Load number” must be set to 10 and “Cell number” to 0.

To initiate the expansion units, "Expansion unit" must be selected at start-up (see below). If the controller does not contain program version 3.0 or later, the initiation must be made via E tool[®]. See the E tool[®] manual for more information on this. However, for this to work, the Exigo must have hardware belonging to the second or third generation.

After the expansion units have been initiated and the master unit set, all inputs and outputs of the unit are available for configuration under Configuration/Inputs/Outputs (the inputs and outputs of the expansion units are labelled Exp1/Exp2). See section 10.3.2 for wiring details.

```
Heating 3.4
Expansion unit 1
Expansion unit 2
```

8.16.3 M-Bus communication

For M-Bus meter communication the bus should be connected to terminal 31 (B) and 32 (A). The function must then be activated, either by using E tool[®] or via the display.

8.16.4 BACnet communication

BACnet communication can take place either via the TCP/IP port or as MS/TP via RS485 (serial). Settings can be made either using E tool[®] or via display.

EDE files are included when installing E tool[®] and are installed under the directory **C:\Program Files\EXO\SLib\Exigo\HeatingProgram3_3\BACnet**.

8.16.5 BACnet/IP configuration

The BACnet/IP protocol is deactivated upon delivery. To enable BACnet communication, simply change the setting "Not active" to "Active". The protocol will now be available for use:

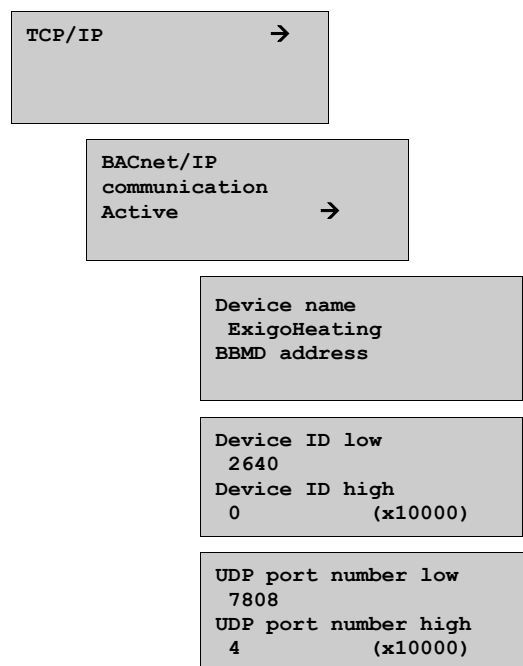

Device name

This is the device name that is shown on the BAS when a device is discovered.

BBMD address

The BBMD address (BACnet/IP Broadcast Management Device) is used for discovering devices that are attached to different BACnet/IP subnets and separated by an IP router. The address is entered as **host:port**, where “host” can be the host’s name if DNS is configured. If DNS is not configured, the host address should be entered in the format “xxx.xxx.xxx.xxx”, followed by the port number (default setting 47808).

Example: mybbmd:47808 (with DNS configured) or 10.100.50.99:47808

Device ID

The ID of a device, used to identify it on the BACnet network. This number **cannot** be duplicated **anywhere** on the BACnet network and must therefore be unique. To set an ID value of 34600, the low number would be set to 4600 and the high number to 3.

8.16.6 BACnet MS/TP configuration

Upon delivery, the BACnet MS/TP protocol is disabled as a default. To enable BACnet communication, the function must first be activated. The default communication settings upon delivery are as follows:

Speed = 9600 bps

MAC address = 0

Device ID = 2640

Max Master = 127

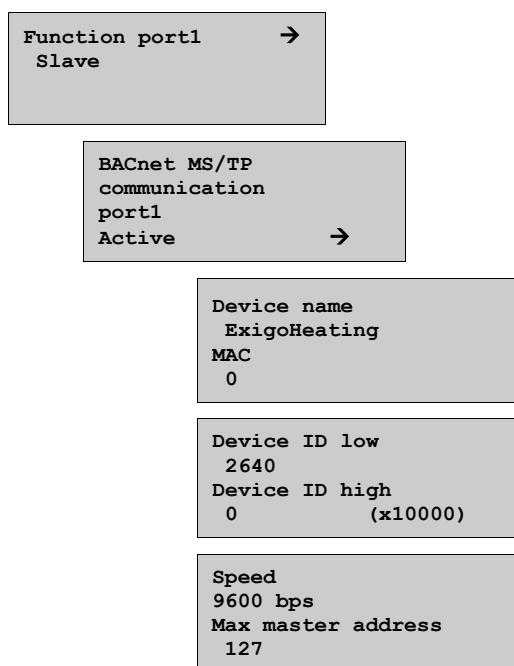

Device name

This is the name of the device, as shown on the BAS when discovering devices.

MAC

The MAC address of the device. This needs to be unique only to the subnet to which the device is attached.

Device ID

The ID of a device, used to identify it on the BACnet network. This number **cannot** be duplicated **anywhere** on the BACnet network and must therefore be unique. To set an ID value of 34600, the low number would be set to 4600 and the high number to 3.

Speed

Sets the communication speed of the MS/TP network. This value is typically set to 38400 or 76800 but can be 9600, 19200, 38400 or 76800.

Max master address

The max master is the MAC address of the highest master device on the BACnet MS/TP network segment. Setting this number above the highest MAC address will decrease network performance.

For additional information, see the Corrigo PICS document, available via www.regincontrols.com.

8.17 Other parameters

A collection of parameters that do not fit into any of the other menus.

```
General
HW1
HP1
```

8.17.1 General

Building inertia and boost

For detailed information, see section 5.1.9.

The building inertia can be set between 0...24 h. 0 = Current outdoor temperature, 24 = Daily average value.

Boost:

```
Displacem.=Factor*(17 - outd. temp)*night set-back
```

The factor is settable 0...10, where 0 gives no boost and 10 gives maximum boost.

The time in minutes that boost will be active is calculated as follows:

```
Time = 1.6*(17 - Outdoor temp)
```

The duration is limited to a maximum of 60 minutes.

```
Building inertia
0 h
Boost factor (0-10)
0
```

Power limitation

The digital input signal *External power limitation* can be used to temporarily restrict power to the heating systems. When activated, the setpoints are lowered by a settable factor (relative to 20°C). The limitation applies to all configured heating systems. The limitation is calculated as below:

```
Limited setpoint=20+(Setpoint-20)*Factor/100
```

```
Power limitation
100 % rel +20°C
```

Factor 100 gives no setpoint reduction, 0 gives full reduction to 20°C.

Frost protection

If a controller is set to Off or Manual control and the outdoor temperature is below a settable value, a minimum, settable supply temperature will be maintained and the pump will run.

```
Frost prot:Off
Outdoor temp activ
Frost prot: 0.0°C
Min sup temp: 10.0°C
```

Split of output signal

Any of the signals HS1, HS2, HS3, CS1, HW1 or HW2 can be split in two.

```
Split of any
temp sequence
No split
```

HS or DHW priority

This function can be set to HS or DHW priority. When one of the circuits is prioritised and does not reach its given setpoint within the set delay time, the remaining circuits will be forced closed. For detailed information, see section 5.1.5 and section 5.3.6.

```
Heat prio: Off
Temp diff: 2°C
Time before prio
30 min
```

8.17.2 HW1

Periodic heating

For activation of periodic heating of HW1. The function is used to prevent the growth of Legionella bacteria. Overheating can take place once a day or once a week. The running time and start time are settable. The function can be aborted if the return temperature exceeds 55°C for 4 minutes.

```
Periodical heating
HW1:Off Day:All
Hour: 2 SetP: 62°C
Running time: 1 min
```

8.17.3 HP1

Periodic heating

For activation of periodic heating of HP1. The function is used to prevent the growth of Legionella bacteria. Overheating can take place once a day or once a week. The running time and start time are settable. The function can be aborted if the return temperature exceeds 55°C for 4 minutes.

```
Periodical heating
HP1:Off
Day:All Hour: 2
Setp: 65°C
```

8.18 System

8.18.1 Change language

Use this menu to change the display language.

```
Choose language
Choose language
English
```

NOTE: This menu is also directly accessible by holding the OK button depressed during power-up or by pressing RIGHT three times when the start display is shown.

8.18.2 Choose start screen (the text normally shown in the display)

There are 4 options to choose from.

Type 1

The second line shows the date and time.

The third line shows the text HS1.

The fourth line shows the present temperature setpoint and actual values for HS1.

```
Heating controller
04:09:15 11:28
HS1
Sp:32.8°C Act:33.1°C
```

Type 2

The second line shows the date and time.

The third line shows the text HW1.

The fourth line shows the present temperature setpoint and actual values for HW1.

```
Heating controller
04:09:15 11:28
HW1
Sp:55.0°C Act:54.8°C
```

Type 3

The second line shows the text HS1/HW1.

The third line shows the present setpoint and temperature for HS1.

The fourth line shows the present setpoint and actual temperature for HW1.

```
Heating controller
HS1/HW1
Sp: 45.5°C Act: 43.8°C
Sp:55.0°C Act:54.8°C
```

Type 4

The second line shows the present outdoor temperature.

The third line shows the text HS1.

The fourth line shows the present temperature setpoint and actual values for HS1.

```
Heating controller
Outd temp: 8.2°C
HS1
Sp:32.8°C Act:33.1°C
```

Type 5

The second line shows the date and time.

The third line shows the text CS1.

The fourth line shows the present temperature setpoint and actual values for CS1.

```
Heating controller
04:09:15 11:28
CS1
Sp:13.0°C Act:12.5°C
```

8.18.3 Automatic summer time adjustment

The internal clock is normally configured for automatic summer/winter time adjustment. The function can be disabled in this menu. When enabled, the clock will be advanced one hour at 02:00 am the last Sunday of March and retarded one hour at 03:00 am the last Sunday of October.

```
Automatic
summer/winter time
change-over
On
```

8.18.4 Address

Exigo uses the below addresses when connecting to E tool[®] and when multiple controllers are connected in a network. E tool[®] normally uses the addresses below, so if an address is changed the new address must also be entered in E tool[®]. If several Exigo are connected in a network, all the units must have the same ELA address, but each unit must have a unique PLA address.

```
Address:
PLA: 254
ELA: 254
```

8.18.5 Display anywhere (remote control)

If multiple Exigo units are connected in a network, it is possible to remote control a unit in the network from a unit with display. This is done by entering the address of the unit you wish to remote control in the unit with display. This function is aborted by pressing the buttons UP, OK and DOWN simultaneously. Addresses up to 99:99 can be used and port 1 should be used for this communication.

```
Address for remote
communication
(PLA:ELA) : 00:00
```

8.18.6 Automatic logoff

If the log on level is set to Operator or Admin, the user will automatically be logged off after a set time of inactivity. The time is settable in units of 5 seconds. Standard 60 units = 5 minutes.

The automatic logoff can be disabled, see 7.5.

```
Time before user
automatically is
logged off: 60
(unit 5 s)
```

Chapter 9 Settings

When accessing one of the control systems, four submenus will be shown. The exceptions are Extra circuit, Boiler and HP1, which only have two submenus each (Actual/Setpoint and Manual/Auto).

Which of the following systems are accessible depends on the configured inputs/outputs.

For more information about access rights and configuration, see chapter 7 and 8..

```
HS1
HS2
HS3
CS1
HW1
HW2
HP1
Boiler
Extra circuit
Time/Extra timers
Holidays
Energy/Cold water
Running mode
Configuration
Access rights
```

Submenus:

Actual/Setpoint: For setting of setpoint values and the slope of curves as well as reading of the actual temperature.

Temp control: For setting of the control parameters.

Manual/Auto: For manual setting of pumps and valves or reading of the present output.

ECO/comf mode: For setting of periods when you want comfort heating or comfort cooling.

```
Actual/Setpoint
Temp control
Manual/Auto
ECO/comf mode
```

9.1 Actual/Setpoint

9.1.1 HS1, HS2 and HS3

```
Outd temp:  -5
°C
HS1
Act: 49.8 °C  Setp→
Setp: 55.0 °C
```

Submenu: Setting of supply temperatures that should correspond to set outdoor temperatures. For each system there are 8 settable breakpoints.

In-between-values are calculated using straight lines between breakpoints. Setpoints for temperatures lower than the lowest node point and higher than the highest node point are calculated by extending the line between the two last node points at either end. Example: At the lower end the setpoint is increasing by 14°C for every 5 °C lowering of the outdoor temperature. This means that the setpoint at -23°C would be $77 + 3/5 * 14 = 85,4^{\circ}\text{C}$.

```
Outd comp setp HS1
-20 °C = 67 °C
-15 °C = 63 °C
-10 °C = 59 °C
```

```
Outd comp setp HS1
-5 °C = 55 °C
0 °C = 53 °C
5 °C = 43 °C
```

```
Outd comp setp HS1
10 °C = 35 °C
15 °C = 25 °C
Man paral dis: 0 °C
```

Each heating system has individual day and night pump stop temperatures. If the outdoor temperature exceeds the set stop value, the circulation pump will stop and the output to the valve actuator is set to 0. The pump will start if the temperature falls below the set stop temperature by more than the set hysteresis and the heating output can also be activated if heating is required. Night is between 00:00 am and 05:00 am. Other than the stop temperatures, it is also possible to enter a start and a stop delay (see section 8.7).

```
Pump stop HS1:On
Stop temp day: 17 °C
Stop temp night: 17 °C
Hysteresis: 2.0 °C
```

Submenu: Room sensor

Setting of the room setpoint. This menu is only active when a room sensor is configured or when an EcoGuard unit is connected.

```
Room sensor HS1
Act: 20.8 °C
Setp: 21.0 °C
```

Submenu: Return temperature

```
Return temp
HS1: 28.0 °C
```

9.1.2 CS1

The cooling system setpoint can be either constant or outdoor compensated. The first display shows the current controlling setpoint. In cases when dew point control has been activated, the current setpoint is displaced if the dew point control offers a higher setpoint.

If constant setpoint:

```
CS1
Act: 13.0 °C
Setp: 13.0 °C
```

If outdoor compensated setpoint:

```
Outd temp: 21.8 °C
CS1
Act: 13.2 °C Setp→
Setp: 13.0 °C
```

Pressing the right key enables setting which supply temperature should correspond to a certain outdoor temperatures when outdoor compensated setpoint has been selected. 8 breakpoints can be set:

```
Outd comp setp CS1
 20 °C = 15 °C
 22 °C = 14 °C
 24 °C = 13 °C
```

```
Outd comp setp CS1
 26 °C = 12 °C
 28 °C = 12 °C
 30 °C = 11 °C
```

```
Outd comp setp CS1
 32 °C = 10 °C
 34 °C = 9 °C
Man paral dis 0 °C
```

In-between-values are calculated in a linear fashion between the points. Setpoints for temperatures lower than the lowest node point and higher than the highest node point are calculated as if the line had continued along the same slope as between its second to last and final point. Example: In the upper end of the curve, the setpoint will decrease with 1°C for every alternating °C rise in the outdoor temperature. This means that the setpoint at 36°C would be 9 - 1 = 8°C.

Each heating system has individual day and night stop temperatures. If the outdoor temperature exceeds the set stop value, the circulation pump will stop and the output to the valve actuator is set to 0. The pump will start if the temperature rises above the set stop temperature by more than the set hysteresis and the cooling output can also be activated if cooling is required. Night is between 00:00 am and 05:00 am. Other than the stop temperatures, it is also possible to enter a start and a stop delay (see section 8.7).

```
Pump stop CS1:On
Stop temp day: 15°C
Stop temp night 15°C
Hysteresis: 2.0 °C
```

Submenu: Room sensor

The room sensor does not influence the temperature control directly.

```
Room sensor CS1
Act: 23.1 °C
```

Submenu: Return temperature

```
Return temp
CS1: 14.0 °C
```

9.1.3 HW1 and HW2

Actual/setpoint value for domestic hot water.

```
Supply temp HW1
Act: 53.0 °C
Setp: 55.0 °C
```

9.1.4 HP1

```
Supply temp HP1  
55.0 °C
```

Submenu: Return temp.

```
Return temp HP1  
45 °C
```

Submenu: Start and stop temperatures for the pump

```
Loading HP1  
Start temp: 46.0 °C  
Stop temp: 55.0 °C  
Temp diff: 2.0 °C
```

9.1.5 Boiler

Different information will be shown in the display depending on the type of setpoint selected for boiler control. For more information, see section 5.6.3.

Option 1 = Constant setpoint:

```
HB setpoint  
36 °C  
HB actual  
36.5 °C
```

Option 2 = Circuit-dependent setpoint:

```
HS-depending setp  
+ 5.0 °C  
HB setpoint: 43.0 °C  
HB actual: 43.2 °C
```

Option 3 = Outdoor compensated setpoint:

```
Outd temp: 5 °C  
HB  
Act: 43.3 °C Setp→  
Setp: 43.0 °C
```

For setting of the outdoor compensated curve, 8 points:

```
Outd comp setp HB  
-20 °C = 67 °C  
-15 °C = 63 °C  
-10 °C = 59 °C
```

```
Outd comp setp HB  
-5 °C = 55 °C  
0 °C = 53 °C  
5 °C = 43 °C
```

```
Outd comp setp HB  
10 °C = 35 °C  
15 °C = 25 °C  
Man paral dis 0 °C
```

Return temperature for boilers 1, 2, 3 and 4:

```
HB1 return temp
Setp: 40.0 °C
Actual: 39.7 °C
```

When “Type of boiler control” is set to “Off/on”, the activation and deactivation points for boiler 1-4 is set via this display menu:

```
HB1 temp: 33.5°C
Start temp1: 5.0 °C
Start temp2: 5.0 °C
Stop temp: 3.0 °C
```

For reading the common return temperature sensor:

```
HB return temp
43.0 °C
```

9.1.6 Extra circuit

Setpoints for the extra circuit temperature sensor as well as pump start hysteresis. In order for the pump to start, extra temp. sensor 1 must be 5°C higher than extra temp. sensor 2. The pump will stop when extra temp. sensor 1 = extra temp. sensor 2. The hysteresis is freely settable.

```
Temp1: 24.6 °C
Temp2: 25.7 °C
Start pump if
T1 > T2 + 5.0 °C
```

9.2 Control temp

General

In order to achieve precision control, the control parameters must be adjusted according to the prevailing conditions. The lower the P-band and I-time, the faster the controller. However, it is important that the values are not set too low as this may lead to the system being unstable. It is also important not to set the values too high as this will make the temperature drift above and below the setpoint.

The P-band gives proportional output to the control error.

The I-time influences the controller output signal over time.

9.2.1 HS1, HS2 and HS3

Setting of the P-band and I-time for the controller.

```
HS1
P-band: 100.0 °C
I-time: 100.0 s
```

Submenu: Only shown for HS1 and HS2.

```
HS1 return temp
P-band: 100.0 °C
I-time: 100.0 s
```

9.2.2 CS1

Setting of the P-band and I-time for the controller:

```
CS1
P-band: 20.0 °C
I-time: 60.0 s
```

9.2.3 HW1 and HW2

```
HW1
P-band: 25.0 °C
I-time: 75.0 s
D-time 0.0 s
```

9.2.4 Boiler

Setting of the P-band and I-time for the controller:

```
Boiler
P-band: 10.0 °C
I-time: 5.0 s
```

Setting of controller blocking time during burner start/stop:

```
Time that the ctrl
is blocked at
start/stop: 180 s
Hysteresis: 0.5 %
```

Setting of return valve controllers, Boiler 1-4:

```
Boiler1 return temp
P-band: 10.0 °C
```

9.3 Manual/Auto

General

This is a very useful feature during commissioning or when troubleshooting.

All the configured control circuits can be controlled manually between 0...100 %. All configured pumps can be set to Auto, Off or On.

A number of other functions can also be run manually.

Leaving any output in manual control means that the normal control will be suspended. Therefore, an alarm will be generated as soon as any output is set to any mode other than Auto.

Since the menus vary according to the configuration of the outputs, only the most common ones will be shown here. Digital signals can, in addition to Auto, normally be set to Off or On, indicating the two possible states of a digital signal.

9.3.1 HS1, HS2 and HS3

Manual operation/reading of the control signal to the actuators.

```
Manual/Auto
HS1
Auto
Manual set: 37
```

Submenu (only HS1 and HS2):

When the controller is set for return temperature control, the output to the actuator will be overridden invertedly, i.e. 100 % will give 0V analogue output.

```
Manual/Auto
HS1 return temp
Auto
Manual set: 37
```

Submenu (only HS1):

When the controller for external power limitation is set to manual, the analogue output will not exceed the set maximum limit for the controller. The output will be between 0 V and the maximum limit.

```
Manual/Auto HS1
Power limit M-Bus
Auto
Manual set: 55.0
```

Submenu: For manual operation/reading of the pumps

```
Manual/Auto HS1
PlA: Auto
PlB: Auto
```

9.3.2 CS1

```
Manual/Auto
CS1
Auto
Manual set: 0.0
```

Submenu: For manual operation of the pump

```
Manual/Auto CS1
PlA:Auto
PlB:Auto
```

Submenu: For manual operation of the digital output CS1, Cool unit start

```
Manual/Auto
cooling unit:
Auto
```

9.3.3 HW1 and HW2

```
Manual/Auto
HW1
Auto
Manual set: 37.0
```

Submenu: For manual operation of the pump (only HW1)

```
Manual/Auto
Pl-HW1:Auto
```

9.3.4 HP1

```
Manual/Auto
HP1:Auto
```

9.3.5 Boiler

Menu for setting burners, circulation pumps, return valves and the transport pump when in manual mode. The menu appearance will vary depending on configuration.

Alt. 1 = Off/on:

Boiler 1-4 can be set to modes Auto/Manual-Off/Start1/Start2 for 2-step burners and to Auto/Manual-Off/Manual-On for 1-step burners.

```
Manual/Auto
Boiler1: Auto
```

Alt. 2 = Control using Off/on/modulating:

When selecting a modulating burner on boiler 1:

```
Manual/Auto
Modulating boiler
Auto
Manual set: 2 %
```

NOTE: This applies not only for the modulating burner but for the entire controller. The control signal is distributed equally between the number of burners. In order to set the modulating burner when in manual mode, it is first necessary to calculate what amount of the controller output signal that constitutes the modulating part. I.e. $100\%/X$ = the percentage to which the controller should be set in order to obtain 10 V on the analogue output, and where “X” is the total amount of burners including the modulating burner.

When in manual mode, the 1- and 2-step burners can be set to modes Auto/Manual-Off/Start1/Start2 for 2-step burners and to Auto/Manual-Off/Manual-On for 1-step burners.

```
Manual/Auto
Boiler2: Auto
```

Alt. 3 = Control using modulating:

In this control mode, the controller can only be set to manual mode. This means that, while in manual mode, it is not possible to set only the burners that start as second, third or fourth burner, as this will result in burners at a lower percentage also starting. In order to circumvent this problem it is possible to either change the burner start order, so the burner to be set in manual mode is set as “Fixed 1:st boiler”. Alternatively, the output can be set to manual mode via the configuration menu.

```
Manual/Auto
Modulating boiler
Auto
Manual set: 56 %
```

For manual operation of boiler pumps 1-4. Can be set to Auto/Manual-Off/Manual-On.

```
Manual/Auto
Boiler pump1
Auto
```

For manual operation of the Transport pump. Can be set to Auto/Manual-Off/Manual-On.

```
Manual/Auto
Transport pump
Auto
```

For manual operation of return valves 1-4. Can be set to Auto/Manual-Off/Manual-On.

```
Manual/Auto
HB1 return temp
Auto
Manual set: 0.0
```

9.3.6 Extra circuit

For manual setting of the extra circuit pump.

```
Manual/Auto
Ext pump: Auto
```

9.4 Economy/Comfort function

General

Each day has two settable comfort temperature periods. When the heating systems are not in their comfort periods, they are set to ECO (economy mode) and the setpoint is lowered by five room degrees (settable), each room degree corresponding to a reduction in the supply temperature setpoint by three degrees. When the cooling system is not in its comfort periods, the supply setpoint is increased by a settable number of degrees.

The comfort function is inactive on delivery and must be activated for each of the different systems if economy mode is to be utilised.

A digital output can be configured to activate the comfort mode. The time for the function to be active after the configured input has closed is freely settable.

9.4.1 HS1, HS2, HS3, HW1, HW2 and CS1

```
HS1 ECO/comf mode
On →
5 room-degrees
```

Submenu: Setting of comfort times

For each control system there are 8 separate setting menus, one for each weekday and one extra for holidays. Holiday schedules take precedence over other schedules.

To run the unit 24 hours a day, a period is set to 00:00 – 24:00.

To disable a period, it is set to 00:00 – 00:00.

```
HS1 comfort time
Monday
Per 1: 07:00 – 16:00
Per 2: 00:00 – 00:00
```

```
HS1 comfort time
Tuesday
Per 1: 07:00 – 16:00
Per 2: 00:00 – 00:00
```

```
HS1 comfort time
Wednesday
Per 1: 07:00 – 16:00
Per 2: 00:00 – 00:00
```

```
HS1 comfort time
Thursday
Per 1: 07:00 - 16:00
Per 2: 00:00 - 00:00
```

```
HS1 comfort time
Friday
Per 1: 07:00 - 16:00
Per 2: 00:00 - 00:00
```

```
HS1 comfort time
Saturday
Per 1: 00:00 - 00:00
Per 2: 00:00 - 00:00
```

```
HS1 comfort time
Sunday
Per 1: 00:00 - 00:00
Per 2: 00:00 - 00:00
```

```
HS1 comfort time
Holiday
Per 1: 00:00 - 00:00
Per 2: 00:00 - 00:00
```

This screen is used to set how long the circuit should remain in comfort mode after the digital input has closed. “Time in ext running” is used to show how long the circuit has remained in comfort mode, but can also be changed manually. By setting “Time in ext running = Extended running”, the circuit can be made to return to economy mode.

```
Extended running
0 min
Time in ext running
0 min
```

9.5 Time/Extra timer outputs

General

Exigo has a year-based clock function with automatic change-over between summer time/winter time. For extra timer outputs 1-5 to be shown in the display, they must first be configured.

```
Time/Date
Timer output1
Timer output2
Timer output3
Timer output4
Timer output5
```

9.5.1 Time/Date

This menu displays and permits changing the time and date.

Time is shown in a 24 hour format.

Date is shown in the format YY:MM:DD.

```
Time: 18:21
Date: 10:01:01
Weekday: Wednesday
```

9.5.2 Extra timer outputs

Up to 5 separate digital timer channels can be configured. Each with individual week-schedules with two activation periods per day. Each output has 8 separate setting menus, one for each weekday and one extra for holidays. Holiday schedules take precedence over other schedules.

```
Timer output1
Monday
Per 1: 07:00 - 16:00
Per 2: 00:00 - 00:00
```

9.6 Holidays

Up to 24 separate holiday periods can be set, for one entire year ahead of time.

A holiday period can be any number of consecutive days from one and upwards. The dates are entered using the format: MM:DD.

When the present date falls within a holiday period, the scheduler will use the settings for the weekday "Holiday".

```
Holidays (mm:dd)
1: 01:01 - 02:01
2: 09:04 - 12:04
3: 01:05 - 01:05
```

9.7 Energy/Cold water

In this menu the pulse-counter input results are administered. The pulse constants (pulses/unit) are set in the menu Configuration/Pulse constants.

```
Heating meter
Cold water meter1
Cold water meter2
Electricity meter
Leakage monitoring
```

9.7.1 Heating meter

```
Energy total
1532.3 MWh
Hot water total
387.02 m3
```

The below values can be reset.

```
Energy
Today: 28.15 kWh
Yesterday: 123.45 kWh
D B Y-day: 132.11 kWh
```



```
Consumption
  Today: 28.15  l
Yesterday: 123.45  l
D B Y-day: 132.11  l
```

```
Power consumption
  Instant: 2100.0
Average/h: 3200.0
  Max aver: 5300.0
```

9.7.2 Cold water meters CW1 and CW2

```
CW1 consump total
  276.22  m3
CW1 flow
  156.4  l/min
```

```
CW1 consump
  Today: 88.1  l
  Yesterday: 4123.4  l
D B Y-day: 5012.1  l
```

```
Lowest CW1 consump
  Today: 0.1  l/h
  Yesterday: 0.2  l/h
```

9.7.3 Electricity meter

```
Energy total
  1866.54  MWh
```

The value can be reset.

9.7.4 Leakage power

```
Leakage monitoring
  1.31  kW
```

9.8 Running mode

Running mode is a read-only menu. No changes can be made here. It is only intended for reading of actual values and alarm history.

```
Alarm events
Inputs/Outputs
Extra sensors
```

9.8.1 Alarm events

Exigo has an alarm log which contains the 40 latest alarm events. The latest event is shown at the top of the list. The alarm log is only used to view alarm history, which may simplify troubleshooting of the installation.

```
14 Jul 18:57 B
Sensor error CS1 return

Activated
```

```
14 Jul 19:05 B
Sensor error CS1 return

Acknowledged
```

```
14 Jul 19:10 B
Sensor error CS1 return

Switches off
```

9.8.2 Inputs/Outputs

In the menu Inputs/Outputs you can read the present raw values from the sensors, the output to the analogue outputs and the present status of the digital inputs/outputs.

```
AI
DI
UI
AO
DO
```

```
AI1: -3.5 Outd temp
AI2: 53.7 HS1 supply
AI3: 54.8 HW1 supply
AI4: 50.6 HS1 return
```

```
DO1: On HS1 pumpA
DO2: Off HS1 pumpB
DO3: Off HS1 inc act
DO4: On HS1 dec act
DO5: On HW1 pump
DO6: On HS2 pumpA
DO7: On Sum alarm
```

9.8.3 Extra sensors

Up to five extra temperature sensors can be connected. These are used for temperature measurement only. The sensors can be given any name by pressing the OK button and using the up/down arrows.

```
Extra sensor 1
Act: 51.2 °C
```

Chapter 10 Expansion units

A unit with at least one RS485 port is required in order for expansion units to be used. See model overview in chapter 2.

10.1 Ports 1, RS485

The port can be set as Slave or Expansion units/External sensor.

When the port is configured to Slave, it is possible to connect the Exigo to a SCADA system (Modbus/EXOLine, see 8.16), or to alternatively connect the unit to E tool[®].

When the port is configured to Expansion units/External sensor, it is possible to connect one or two expansion units to the port, as well as one EcoGuard unit. The expansion units must be Exigo controllers of either the second or third generation.

It is completely possible to use a Exigo with display as an expansion unit. However, there is no practical reason to do so as the expansion unit display cannot be used, nor display any information.

The first time you start up a slave controller without display, an external display is required to activate the controller as an expansion controller. If the initiation is done via E tool[®], an external display is not required.

All configuration takes place using E tool[®], or via the display on the master controller. All inputs and outputs can be viewed in the master controller.

10.2 M-Bus

In a unit adapted for M-Bus (HC193DWM-1), it is possible to connect terminals 31 and 32 to an M-Bus meter. A maximum of three meters can be connected.

10.3 Wiring

10.3.1 M-Bus meter

This function requires an Exigo with the letter “M” in its model name (HC193DWM-1). It is possible to connect one district heating meter and two water meters:

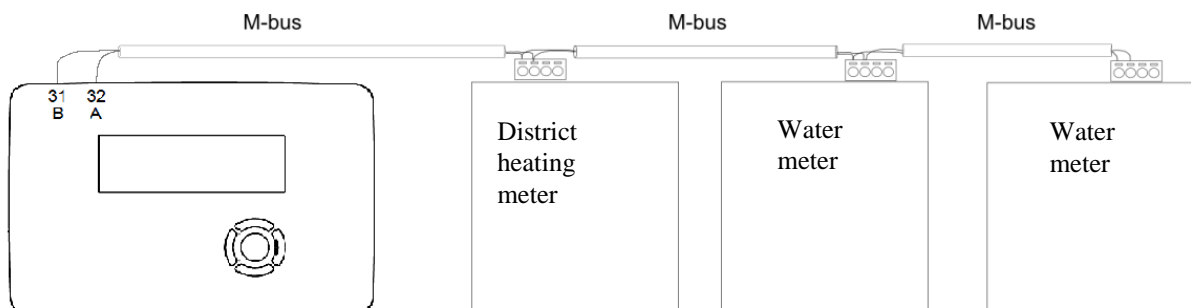

The following variables can be read from the meters:

- Supply temperature
- Return temperature
- Delta temperature Supply/Return
- Energy
- Output
- Volume
- Flow

10.3.2 Expansion units EXOline

The communication between master and expansion units takes place via EXOline. The slave units will be assigned the address 241:1 and 241:2 during initialisation (PLA:ELA).

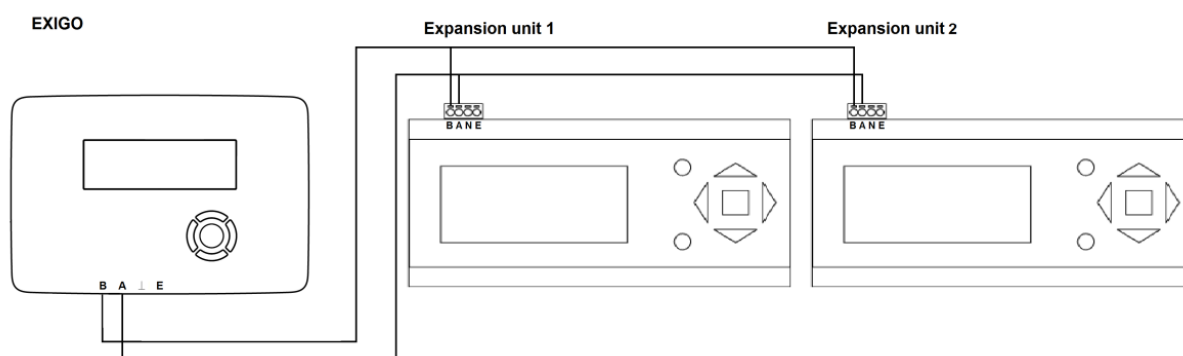

Chapter 11 Other functions

11.1 Alarm handling

Alarms are logged in the alarm list. The list shows the type of alarm, the alarm date and time and the alarm priority (A, B or C alarms).

To access the alarm list, simultaneously press LEFT and UP on the Exigo, or press the alarm button (the one with the red top) on the front of the E3-DSP unit.

```
Sensor error
24 Aug 10:43 Class:B
Reset          ▼
```

If there are multiple alarms, this is indicated by up/down arrow symbols at the right-hand edge of the display.

Use the UP and DOWN buttons to access the other alarms.

At the left end of the bottom display line the alarm status is shown. For active, unacknowledged alarms the space is blank. For alarms that have reset the text: Acknowledged, still active or blocked alarms are indicated by Acknowledged or Blocked.

Alarms are acknowledged by pressing the OK button. You are then given the choice of acknowledging the alarm or blocking the alarm.

Acknowledged alarms will remain on the alarm list until the alarm input signal resets.

Blocked alarms remain on the alarm list until the alarm has reset and the block has been removed. New alarms of the same type will not be activated as long as the block remains.

Since blocking alarms can be potentially hazardous, you need a high log on authority to block alarms.

Class A, B and C alarms will activate alarm output(s) if these have been configured.

Class C alarms are removed from the alarm list and resets without acknowledgment when the reason for the alarm has been removed, e.g. manual mode.

Alarm log

Exigo also has an alarm log which contains the 40 latest alarm events. For more information, [see section 9.8.1](#).

11.4 Optional information screen

If pressing RIGHT once when the start-menu is shown, a menu showing text of your choice is displayed. This text can be used to show information concerning the commissioning company, name and phone number to service personnel, etc. The easiest way to enter text is using E tool[®]. Up to 4 lines of 20 characters each can be entered.

11.5 Revision number

If pressing RIGHT twice when the start-menu is shown, a menu showing the program revision number and ID number is displayed.

Index

A

Actual/Setpoint, 62
Address, 61
Alarm configuration, 49
Alarm list, 49
Alarm settings, 36
Alarms, 31
 Alarm handling, 77
 Alarm list, 49
Analogue inputs, 12
Analogue outputs, 12

B

BACnet/IP, konfigurering, 56
Boiler control, 25
Boost, 58
Building inertia, 58

C

Change language, 60
Change password, 35
Cold water monitoring, 29, 30
Comfort function, 70
Communication, 54
Configuration, 36
 Inputs and outputs, 38
 Running time, 3-position actuators, 48
Control function CS1, 42
Cooling system, 23

D

Dew point control, 42
Digital inputs, 12
Digital outputs, 13
Display, LEDs and buttons, 32
Domestic hot water, 24

E

Economy function, 70
Electricity meter, 31
Energy monitoring, 30
Energy/Cold water, 72
Exercising, 48
Expansion units, 75

H

Heating meter, 72
Heating system, 20

I

Information screen, 77
Inputs and outputs, 12, 38
 Analogue inputs, 12
 Analogue outputs, 12
 Digital inputs, 12
 Digital outputs, 13
 Input and output lists, 13
 Universal inputs, 12

L

Language, change, 60
Leakage monitoring, 48
Log off, 34
Log on, 34

M

Manual/Auto, 67
M-Bus, power limitation, 23

O

Optimisation, 41
Optional information, 77

P

Password, 35
Power limitation M-Bus, 42
Pulse inputs, 49
Pump stop, 45

R

Remote control, 61
Return temperature limitation, 44
Return temperature limits, 42
Revision number, 77
Run indication/Motor protection, 46
Running time, 3-position actuators, 48

S

Setpoint
 Boiler, 44
Summer time adjustment, 61

T

Temperature control

Settings, 62
Timer channel outputs, 31
Twin/Single pump, 46

U

Universal inputs, 12

REGIN - THE CHALLENGER IN BUILDING AUTOMATION

AB Regin

Head office

Box 116, S-428 22 Källered,
Sweden

Phone: +46 31 720 02 00

Fax: +46 31 720 02 50

info@regin.se

www.regincontrols.com



THE CHALLENGER IN BUILDING AUTOMATION