

DTLI50...I650

Differential pressure transmitter for air and non-corrosive gases with settable working range



DTL is a transmitter for differential pressure measurement of air and non-corrosive gases in air handling units etc.

- ✓ Three settable working ranges for each model
- ✓ Output signal 0...10 V DC or 4...20 mA
- ✓ High level of accuracy and stability
- ✓ Quick and easy mounting

Application

A common application area is pressure control in ventilation systems.

Function

The transmitter consists of a plastic sensor housing and a membrane of silicone LSR. The differential pressure affects the membrane which is connected to the sensor element. The element is manufactured with state-of-the-art technology and has a ceramic beam onto which thick-film resistors have been applied. The pressure on the membrane causes a movement which is transferred to the ceramic beam. A change in pressure will lead to a change in resistance. The changes in resistance are transmitted by means of built-in electronics to an analogue output signal. The measuring element gives a rapid response and a high level of accuracy. The properties of the ceramic element ensure that the transmitter has excellent long-term stability.

Sensor housing

The sensor housing is made of transparent plastic. The cable input is on the left hand side and has a cable gland. The cover is closed by a single screw and can easily be detached from the hinges during mounting.

Display

All models are available either with or without display (article number with or without -D).

Installation

The sensor is normally mounted vertically using screws in the mounting holes in the back edge. There are also two mounting holes in the upper side of the sensor housing.

Connection set

A connection set consisting of tubing and pressure outlets is included as an accessory to the transmitter.

Setting the working range

The transmitter has three different working ranges depending on the model. The working ranges are set via two dipswitches in the lower left corner of the circuit board according to the table below. The supply voltage must be disconnected. You can also change the zero point of the pressure measurement by pressing the button above the dipswitches.



	SW1	SW2
Working range 1	ON	OFF
Working range 2	OFF	ON
Working range 3	OFF	OFF

ON
1 2

Technical data

Supply voltage	24 V AC +/- 15 % or 13.5...33 V DC (8...33 V DC for 4...20 mA)
Power consumption	10 mA (0...10 V), 30 mA (4...20 mA)
Output signal	0...10 V DC or 4...20 mA
Load impedance	>10 kOhm (0...10 V), 1250 Ohm (4...20 mA)
Max. allowed diff. pressure	Working ranges up to (and including) 300 Pa: 5 kPa. Working ranges over 300 Pa: 10 kPa
Pressure connections	Connection pipes for 6.2 mm tube
Cable connection	Screw terminals. PG11 strain relief
Cable	Three wire. A flexible cable is recommended
Mounting	Vertically on a wall or similar with the pressure connections downwards
Protection class	IP54
Weight	0.1 kg
Accuracy, linearity	<+/- 1.0 % fs: working ranges within 0...100 Pa, +/- 0.7 % fs: higher working ranges ¹
Accuracy, hysteresis	<+/- 1.0 % fs
Temperature dependence	<0.04 % fs/°C
Ambient temperature	0...70°C
Storage temperature	-10...+70°C
Dynamic response time	<20 ms
Resolution	Working ranges up to (and including) 100 Pa: 0.2 % fs, other working areas: 0.1 % fs

1. fs = fullscale, the complete sensor range



This product carries the CE-mark. More information is available at www.regincontrols.com.

Material

Material, sensor housing	PVC, fireproof according to UL94 V-0
Material, membrane	LSR (silicone)

Models

Article	Working range 1	Working range 2	Working range 3	Output signal
DTL150(-D)	0...100 Pa	0...300 Pa	0...500 Pa	0...10 V DC
DTL150-420(-D)	0...100 Pa	0...300 Pa	0...500 Pa	4...20 mA
DTL310(-D)	0...300 Pa	0...500 Pa	0...1000 Pa	0...10 V DC
DTL310-420(-D)	0...300 Pa	0...500 Pa	0...1000 Pa	4...20 mA
DTL516(-D)	0...500 Pa	0...1000 Pa	0...1600 Pa	0...10 V DC
DTL516-420(-D)	0...500 Pa	0...1000 Pa	0...1600 Pa	4...20 mA
DTL1650(-D)	0...1600 Pa	0...2500 Pa	0...5000 Pa	0...10 V DC
DTL1650-420(-D)	0...1600 Pa	0...2500 Pa	0...5000 Pa	4...20 mA

Accessories

Article	Description
ANS-20	Two pressure outlets (straight) and 2 m plastic tube
ANS-3	Two pressure outlets (metal, 90° angle) and 2 m plastic tube

Dimensions

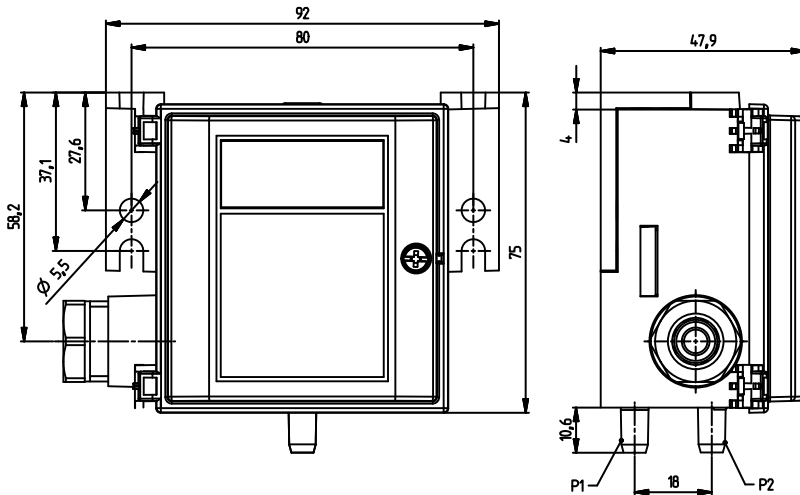

(P1 and P2 = Pressure ports 1 and 2)

[mm]

Wiring

0...10 V

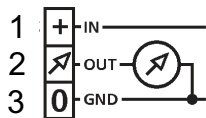

1. Supply voltage 24 V AC / 13,5...33 V DC
2. Output signal 0...10 V DC
3. System neutral

4...20 mA

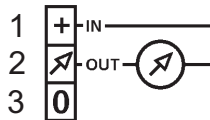

1. Supply voltage 8...33 V DC
2. Output signal 4...20 mA
3. Not connected

Documentation

All documentation can be downloaded from www.regincontrols.com.