



Corrigo E manual

Ventilation application



© Copyright AB Regin, Sweden, 2013



REGIN

THE CHALLENGER IN BUILDING AUTOMATION

DISCLAIMER

The information in this manual has been carefully checked and is believed to be correct. Regin however, makes no warranties as regards the contents of this manual and users are requested to report errors, discrepancies or ambiguities to Regin, so that corrections may be made in future editions. The information in this document is subject to change without prior notification.

The software described in this document is supplied under licence by Regin and may be used or copied only in accordance with the terms of the licence. No part of this document may be reproduced or transmitted in any form, in any fashion, electronically or mechanically, without the express, written permission of Regin.

COPYRIGHT

© AB Regin. All rights reserved.

TRADEMARKS

Corrigo E, E tool[®], EXOdesigner, EXOreal, EXOline, EXO4, EXO4 Web Server, Optigo, Regio and Regio tool are registered trademarks of AB Regin.

Windows, Windows 2000, Windows XP, Windows Vista, Windows 7, Windows 8 and Windows Server 2003 are registered trademarks of Microsoft Corporation.

Some product names mentioned in this document are used for identification purposes only and may be the registered trademarks of their respective companies.

Revision Q, June 2013

Software revision: 3.2

Table of contents

CHAPTER 1 ABOUT THE MANUAL	6
More information	6
CHAPTER 2 ABOUT CORRIGO E	7
2.1 News in version 3.2.....	7
2.2 Application choice	8
2.3 Technical data.....	11
CHAPTER 3 INSTALLATION AND WIRING.....	14
3.1 Installation	14
3.2 Wiring	14
CHAPTER 4 COMMISSIONING	26
4.1 How to do it	26
CHAPTER 5 FUNCTIONAL DESCRIPTION	29
5.1 Temperature control	29
5.2 Extra control circuit	42
5.3 Humidity control.....	42
5.4 Fan control.....	43
5.5 Pump control	49
5.6 Damper control.....	50
5.7 Extended running and External switch	51
5.8 Time-switch outputs	51
5.9 Alarms.....	51
CHAPTER 6 STARTING AND STOPPING THE UNIT	53
6.1 Start conditions.....	53
6.2 Stop conditions	53
6.3 Start sequence	54
6.4 Stop sequence	54
CHAPTER 7 DISPLAY, LEDS AND BUTTONS	55
7.1 Display	55
7.2 LEDs	55
7.3 Buttons	55
7.4 Navigating the menus.....	55
CHAPTER 8 ACCESS RIGHTS.....	57
8.1 Log on	57
8.2 Log off.....	57
8.3 Change password.....	58
8.4 Change password to remove automatic logoff	58
CHAPTER 9 RUNNING MODE	59
9.1 Running mode, unit	59
9.2 Selected functions	59
9.3 Alarm events.....	60
9.4 Inputs/Outputs	60
CHAPTER 10 TEMPERATURE	61
CHAPTER 11 AIR CONTROL.....	65
CHAPTER 12 HUMIDITY CONTROL.....	68
CHAPTER 13 TIME SETTINGS	69
13.1 Time / Date	69
13.2 Timer Normal speed	69
13.3 Timer Reduced speed	70

13.4 Extended running	70
13.5 Timer outputs 1...5.....	70
13.6 Holidays	71
CHAPTER 14 MANUAL / AUTO	72
CHAPTER 15 SETTINGS	75
15.1 Control temp.....	75
15.2 Control pressure	76
15.3 Control flow	76
15.4 Humidity control.....	77
15.5 Control Extra unit.....	77
15.6 Alarm settings.....	77
15.7 Save and restore settings.....	79
CHAPTER 16 CONFIGURATION	80
16.1 Inputs and outputs.....	80
16.2 Control function.....	82
16.3 Fan control.....	83
16.4 Extra control circuit	84
16.6 Extra sequence Y5.....	84
16.7 Heating coil	84
16.8 Exchanger	85
16.9 Chiller.....	85
16.10 Pump control	86
16.11 Free cooling	87
16.12 Support control.....	87
16.13 CO ₂ /VOC Demand control.....	88
16.14 Fire function.....	88
16.15 Humidity control.....	89
16.16 Exchanger de-icing.....	89
16.17 Cooling recovery	89
16.18 Minimum limit dampers	89
16.20 External setpoint.....	89
16.21 Run indication / Motor protection	90
16.22 Actuator type	90
16.23 Running time, 3-position actuators	91
16.24 Step controllers.....	91
16.25 Recirculation	93
16.26 Pretreatment	93
16.27 Alarm setting	94
16.28 Communication	98
16.29 Other parameters	100
16.30 System	103
CHAPTER 17 EXPANSION MODEL.....	106
17.1 Port 1	106
17.2 Port 2	106
17.3 Wiring	106
CHAPTER 18 OTHER FUNCTIONS.....	108
18.1 Alarm handling.....	108
18.2 Free text.....	108
18.3 Revision number	108
18.4 Language.....	109
18.5 Indication LEDs	109
18.6 Changing the battery	109
18.7 Start-up wizard	110
18.8 Energy calculation.....	112
18.9 SFP (Specific Fan Power).....	112
INDEX	113

Chapter 1 About the manual

This manual covers all the models in the Corrigo E series used with the ventilation application. This revision covers program revisions from 3.2.

More information

More information about Corrigo E can be found in:

- *Manual E tool*[®] – Manual of how to configure the controllers using the PC software E tool[®]
- *Corrigo E ventilation user guide* – A simplified manual
- *Lon-interface variable list* – Variable list for the Corrigo E series
- *Network variables for EXOline and Modbus* – Variable list for EXOline and Modbus communication
- *Corrigo E ventilation Modbus Communication Guide* – A guide to Modbus communication and the most common Modbus variables
- *Editable PDF files for Corrigo*
- *CE - Declaration of conformity, Corrigo E*

The information is available for download from Regin's website, www.regin.se.

Chapter 2 About Corrigo E

Corrigo E series comprises three model sizes: 8, 15 or 28 in-/outputs.

In each model of Corrigo E generation 2, all applications are loaded in a separate memory area. The models have article number E...-S (where S stands for Second generation). From version 3.0, there are models with two communication ports. By connecting one/two expansion units to port two on these units, it is possible to increase the number of inputs and outputs. The 2-port Corrigo models have article number E...2-S (where the number two stands for 2 ports). For more detailed information, see chapter 17.

The controllers are available with or without front panel display and buttons. For units without front panel display and buttons a separate, cable-connected terminal E-DSP with display and buttons is available.

All configuration and normal handling can be done using the display and buttons or using the configuration tool E tool[®], installed on a PC and connected via the communication cable E-cable.

2.1 News in version 3.2

- Split of analogue output signal Y1 Heating/Y3 Cooling (change-over).
- Digital output connected to split sequence.
- Extra sequence Y5 added.
- Temperature-dependent air flow compensation has been added. It can be set either to affect normal speed or both normal and reduced speed.
- Air flow compensation depending on controller output, one for heating output and one for cooling output.
- Separate setpoint at reduced speed.
- Runtime indication as digital output.
- New room units for remote control, with or without display or as touch display.
- Outdoor temperature-dependent room/extract air-compensated setpoints.
- Inverted function on digital out alarm indication.
- Communication with two LS frequency converters.
- Extract air fan (EAF) can now be run during recirculation.
- Energy calculation.
- Port 2 has been updated and can now communicate with a SCADA system via Modbus (earlier, port 2 could only communicate with E tool[®]).
- New fan control function. Frequency controlled extract air fan with a supply air fan as slave.
- Possible to change temperature unit from Celsius to Fahrenheit, as well as to set flow unit either to m³/h (cubic meters per hour) or CFM (cubic feet per minute).
- Program date in display (date when software version was manufactured).
- The digital heating output now has a PWM function (Pulse-Width Modulation).
- New analogue input signal, external flow setpoint.
- Configuration of min./max. input signal (volt) for pressure transmitters.
- Modbus communication with EBM fans.

- Frost protection on extra sequence Y4.
- SFP (Specific Fan Power) – A way to calculate power consumption per flow unit (kW / m³/s).
- Romanian language support.
- Changeable X value (outdoor temperature) for outdoor compensated setpoints in display and web site.
- The order of priority for fire alarms has been changed.
- CO₂/VOC control on extra sequence Y4.

2.2 Application choice

On delivery, the main memory in the Corrigo is empty. All the application programs that can be run in the Corrigo are located in a separate memory area.

On the first start-up, the controller will start a special program for downloading a suitable application and suitable languages to the main memory.

For certain customised models, an application has already been selected when the product is delivered. If so, the selected application will be started immediately.

```
Corrigo E Controller
08:01:01  00:00
Select application
with down arrow
```

First press OK to set the date and time. Use the up and down arrows to change values and the right and left arrows to move between fields. When the date has been set, press OK and the cursor will move to the scheduler. Set the time in the same way as the date and press OK to confirm.

Press down arrow to go to "Application choices".

```
→Ventilation
  Heating
  Boiler
  Expansion Unit 1
  Expansion Unit 2
```

Use the up and down arrows to move the cursor in the left edge of the display to the application you wish to load. Press right arrow to choose the selected application and go to Language choice.

```
Ventilation
Choose language
English
Accept changes:No
```

Press OK to choose language. Use the up and down arrows to move between languages and press OK to confirm your choice.

When another language than English is chosen, both English and the selected language will be loaded.

To make the final confirmation of the created programs and language choices, change No to Yes and confirm by pressing OK.

After a few seconds, the display will show a start display in English for the chosen application. After another few seconds, the display text will change to the selected language, if another language than English has been selected.

```
Regulator vent. sys
08:06:03  09:32
System:Stopped
Sp: 19.5 Act: 20.1°C
```

2.2.2 Ventilation application

The temperature controller is based on a supply air PI-controller for heating control with a pre-programmed set of control modes. A number of different control functions as well as analogue and digital in- and output functions can be bound to this controller. The choice of which functions are to be used is free, the only restriction is the physical number of inputs and outputs of the different models. The maximum number of I/Os is 3*28 (a 2-port Corrigo with two expansion units).

The Corrigo is designed for DIN-rail mounting.

The program for an air handling unit contains, apart from other things, the following functions:

Different temperature control modes:

Supply air control.

Outdoor compensated supply air control.

Room temperature control (cascade control).

Extract air control (cascade control).

Outdoor temperature dependent supply air or room temperature control.

Outdoor temperature dependent supply air or extract air control.

Outdoor compensated room temperature control.

Outdoor compensated extract air control.

With control of:

Heat exchanger (Liquid connected- , plate- or rotating) or mixing dampers.

Heating coil; Water with frost protection or electric.

Chiller: Water-heated or DX in up to three steps.

Circulation pumps heating, cooling, exchanger.

Fan control

1- or 2-speed supply air fans and extract air fans.

Frequency controlled supply and extract air fans with pressure or flow control, manual control or external control from a VAV system. Pressure controlled supply air fan with slave connected extract air fan (output dependent or flow dependent). Pressure controlled extract air fan with slave connected supply air fan (output dependent or flow dependent).

Humidity control

Either humidification or dehumidification, or both humidification and dehumidification.

Timer control

For starting and stopping the unit. Up to five timer outputs for control of external functions such as lighting, doorlocks etc.

Demand control

In buildings with strongly varying occupancy the fan speeds or mixing dampers can be controlled by the air quality measured by a CO₂/VOC sensor.

Support control

When using the control function room control or extract air temperature control, it is possible to utilise support-heating and/or support-cooling. Minimum running time is settable 0...720 minutes (factory setting 20 minutes).

Free cooling

The function is used during the summer to cool the building during the night using cool outdoor air thereby reducing the need to run chillers during the day. The function can also be activated during daytime if the temperature so allows.

Enthalpy control for free cooling/heating

This function is used to override the mixing damper to increasing recirculation depending on the result of the enthalpy calculation.

Cooling recovery

If the extract air is colder than the outdoor air and cooling is required, the heat exchanger control is reversed in order to return the cool extract air. This function also activates the heating function "Free heating" (see section titled "Free heating" below).

Free heating

If the extract air is cooler than the outdoor air and heating is required, outdoor air will primarily be used.

Recirculation control

Recirculation of air using a supply air fan and recirculation damper, with or without temperature control.

Pretreatment

Preheating or precooling of the intake air via an underground intake channel.

Step controllers Heating/Cooling

As an alternative to the analogue control of "Actuator heating Y1" or "Actuator cooling Y3", step controllers can be used to control heating or cooling in steps using digital control.

Corrigo E hardware overview

Model	E8-S	E8D-S	E15-S	E15D-S	E28-S	E28D-S
Analogue Inputs	2	2	4	4	4	4
Digital Inputs	3	3	4	4	8	8
Universal Inputs	-	-	-	-	4	4
Analogue Outputs	1	1	3	3	5	5
Digital Outputs	2	2	4	4	7	7
RS485*	Yes	Yes	Yes	Yes	Yes	Yes
LON	Option	Option	Option	Option	Option	Option
WEB (TCP/IP)	Option	Option	Option	Option	Option	Option
2-port	No	No	Option	Option	Option	Option
Display	No	Yes	No	Yes	No	Yes
Ext. display	Option	No	Option	No	Option	No

*Communication port RS485 is not available for option WEB (TCP/IP). However, a 2-port Corrigo with TCP/IP and RS485 can be selected, where RS485 is used for expansion units etc.

Corrigo E model overview

Model with display	Model without display	Description
E8D-S, E15D-S, E28D-S	E8-S, E15-S, E28-S	Standard controller with RS485 port
E8D-S-LON, E15D-S-LON, E28D-S-LON	E8-S-LON, E15-S-LON, E28-S-LON	Controller with both LON and RS485 ports
E8D-S-WEB, E15D-S-WEB, E28D-S-WEB	E8-S-WEB, E15-S-WEB, E28-S-WEB	Controller with TCP/IP port and built-in web server
E152D-S, E282D-S	E152-S, E282-S	Controller with two RS485 ports for connection of expansion units
E152D-S-WEB, E282D-S-WEB	E152-S-WEB, E282-S-WEB	Controller with RS485 port and built-in web server. For connection of expansion units

2.3 Technical data

Protection class	IP20
Display.....	4 rows of 20 characters. Background illumination.
LEDs	
Yellow	Settable parameter
Red	Alarm indication
Clock	Year base 24 hour clock with battery backup.
	Automatic summer-/winter-time changeover.
Operating system	EXoreal
Supply voltage	24 V AC $\pm 15\%$, 50...60 Hz or 21...36 V DC
Power consumption	5 VA, 3 W (DC), model WEB: 9 VA, 5 W (DC)
Dimensions	148x123x60 (WxHxD incl. terminals)
Casing.....	Standard Euronorm (8.5 modules wide)
Mounting	On DIN-rail
Operation	
Climatic conditions according to IEC 721-3-3	Class 3k5
Ambient temperature	0...50°C
Ambient humidity	Max 95% RH
Mechanical requirements according to IEC721-3-3	Class 3M3
Vibration.....	IEC60068-2-6, Test FC, vibration Sinusoidal
Shock	IEC60068-2-27, Test Ea

Transport	
Climatic conditions according to IEC 721-3-2	Class 2k3
Ambient temperature	-20...70°C
Ambient humidity	Max 95% RH
Mechanical requirements according to IEC721-3-2	Class 2M2
Vibration.....	IEC60068-2-6, Test FC, vibration Sinusoidal
Shock	IEC60068-2-27, Test Ea
Free fall.....	IEC60068-2-27, Test Ed
Storage	
Climatic conditions according to IEC 721-3-1	Class 1k3
Ambient temperature	-20...70°C
Ambient humidity.....	Max 95% RH

Battery

Type.....	Replaceable Lithium cell, CR2032
Battery life	Better than 5 years
Warning	Low battery warning
Battery backup.....	Memory and real time clock

Communication

EXOline Port 1, insulated via a built-in RS485 contact.
 EXOline Port 2, insulated via a built-in RS485 contact (only 2-port Corrigo models).
 The basic version of Corrigo E can communicate with Modbus. You do not need an activation code.
 Corrigo E can be ordered with a communication port for TCP/IP or LON.

EMC emission and immunity standard

This product conforms to the requirements of the EMC Directive 2004/108/EC through product standards EN 61000-6-1 and EN 61000-6-3.

RoHS

This product conforms to the Directive 2011/65/EU of the European Parliament and of the Council.

Inputs

Analogue inputs AI.....	Settable 0...10 V DC or PT1000, 12 bit A/D
Digital inputs DI.....	Potential-free closure
Universal inputs UI.....	Can be set to act as either an analogue input or
...	a digital input with specifications as above

Outputs

Analogue outputs AO	Configurable 0...10 V DC; 2...10 V DC;
...	10...0 V DC or 10...2 V DC
	8 bit D/A short-circuit protected
Digital outputs DO	Mosfet outputs, 24 V AC/DC, 2 A continuous.
	Totally max 8 A.

Options

LON.....	FT3150, gives a second communication route
WEB (TCP/IP-port).....	Replaces RS485 for EXOline (Port 1) communication
2-port Corrigo models	Two serial ports or one serial port and one TCP/IP port
External hand terminal, E-DSP	For use with Corrigo E units without display

Position of the terminals on Corrigo E

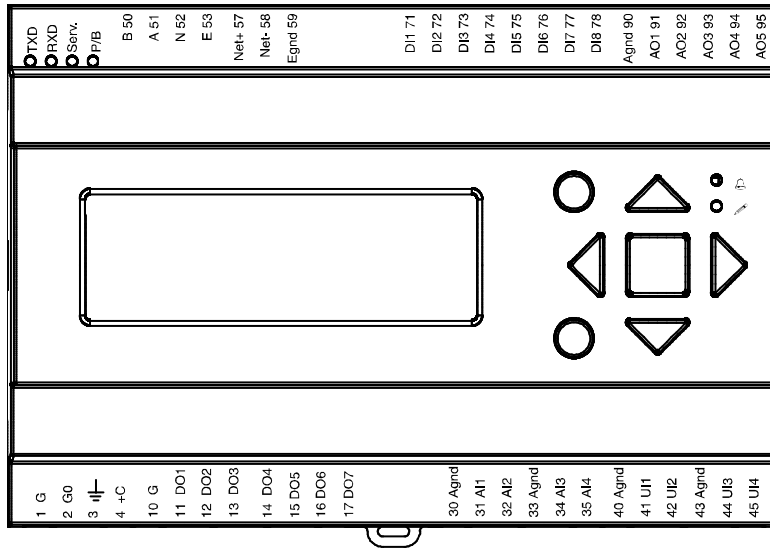

Chapter 3 Installation and wiring

3.1 Installation

Corrigo E can be mounted in a DIN-standard casing (minimum 9 modules), on a DIN-rail in a cabinet or, using a suitable front-mounting kit, in a cabinet door or other control panel.

Ambient temperature: 0...50°C.

Humidity: Max. 90 % RH, non-condensing.

The picture below shows a wiring example for Corrigo E28.

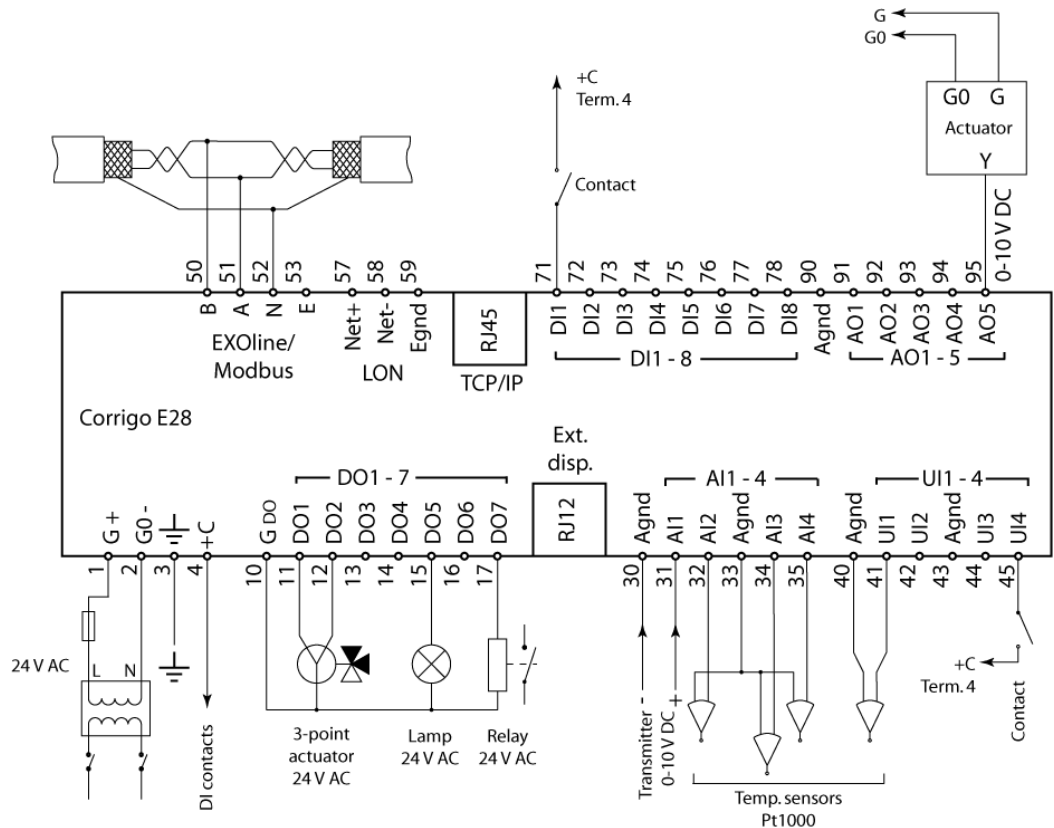

3.2 Wiring

At the end of this chapter there are wiring diagrams showing the factory set configuration. There are also empty wiring diagrams. Since the function of most of the inputs and outputs depends on the programming of the unit the final wiring diagram cannot be filled in until the installer has decided how to use the inputs/outputs. It is important to ensure that the wiring is performed correctly and in accordance with the instructions given in this manual.

3.2.1 Supply voltage

24 V AC $\pm 15\%$, 50...60 Hz or 21...36 V DC

If Corrigo E and its connected actuators share the same transformer, it is essential that the same transformer pole is used as reference for all the equipment. The equipment may otherwise not function as intended and may also suffer damages.

3.2.2 Inputs and outputs

The list of input and output functions in section 3.2.3 is a handy instrument to help you keep track of which inputs and outputs you will need to configure.

Analogue inputs

Analogue inputs must refer to an Agnd terminal placed in the same terminal block as the input being wired.

Analogue inputs can, depending on the configuration, be used for either PT1000 temperature sensors or for 0...10 V DC analogue input signals, for example from a pressure transmitter.

Digital inputs

Digital inputs must refer to +C on terminal 4. Digital inputs may only be wired to voltage-free contacts. Any external voltage applied to a digital input may harm the unit. The input signal can be set to either NO or NC.

Universal inputs

A universal input can be configured to act as either an analogue input or as a digital input.

A universal input configured as an analogue input can, depending on the configuration, be used for either PT1000 temperature sensors or for 0...10 V DC analogue input signals, for example from a pressure transmitter.

Universal inputs configured as an analogue input must refer to an Agnd terminal placed in the same terminal block as the input being wired.

A universal input configured as a digital input must, just like other digital inputs refer to C+ on terminal 4. It may only be wired to voltage-free contacts.

Analogue outputs

Analogue outputs must refer to the Agnd terminal placed in the AO terminal block.

All analogue outputs can be individually set to any one of the following signals:

0...10 V DC

2...10 V DC

10...0 V DC

10...2 V DC

If the Corrigo E and the actuators connected to it share the same transformer it is essential that the same transformer-pole is used as reference for all the equipment. Failure to do so will prevent the equipment from functioning as intended and may also lead to damages.

Digital outputs

Digital outputs should normally refer to G_{DO} on terminal 10. G_{DO} is internally connected to G on terminal 1 and supplies 24 V AC or DC depending on the choice of supply voltage.

All the digital outputs are controlled by MOSFET transistors. The outputs are internally connected with G₀ and can deliver max 2 A per output. However, the total power for all the DOs must not be over 8 A.

A number of different wiring alternatives are possible depending on the type of supply voltage to the Corrigo and the relay type.

24 V AC supply and 24 V AC relays

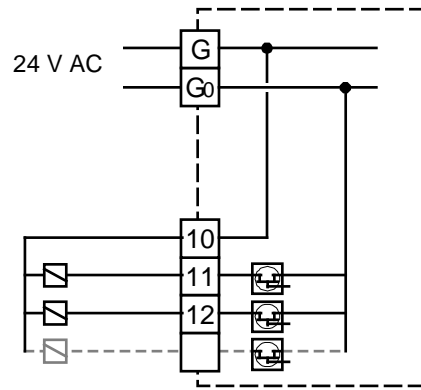

24 V DC supply and 24 V DC relays

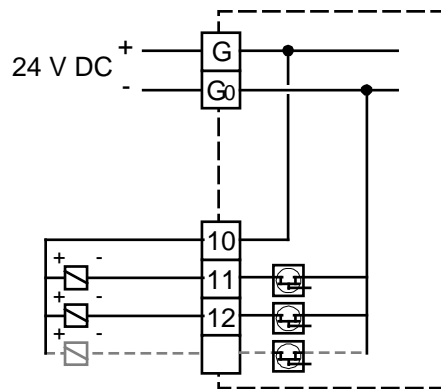

24 V AC supply and 24 V DC relays

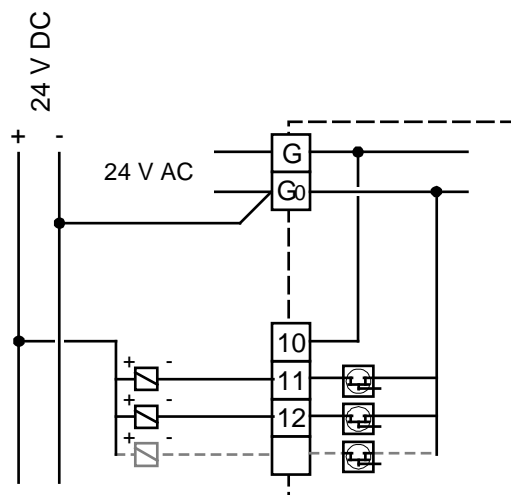

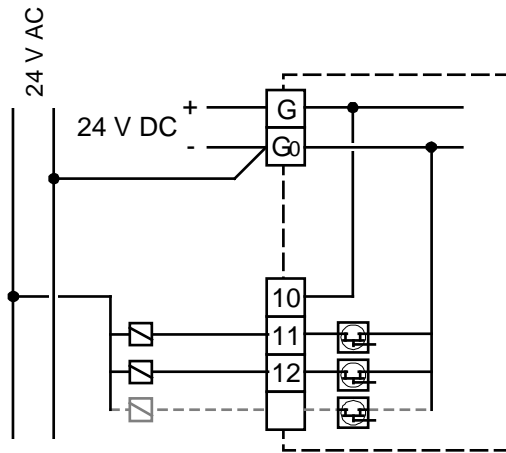

3.2.3 Input and outputlists

The lists below are intended to be used during commissioning to help you keep track of the desired input and output functions.

The left column contains a description of the in-/output signal, the middle column displays the name of the corresponding signal in E tool[®] and the right column shows the text displayed in the Corriego E controller.

Analogue input signal

✓	Description	E tool [®]	Display
	Inactive input	Not used	Not used
	Outdoor temperature sensor	Outdoor Temp	Outdoortemp
	Supply air temperature sensor	Supply Air Temp	Supplytemp
	Extract air temperature sensor	Extract Air Temp	Extracttemp
	Exhaust air temperature sensor	Exhaust Air Temp	Exhausttemp
	Room temperature sensor 1	Room Temp 1	Roomtemp1
	Room temperature sensor 2	Room Temp 2	Roomtemp2
	CO ₂ sensor, 0...10 V DC	CO2 Sensor	CO2
	Pressure transmitter supply air, 0...10 V DC	SAF Pressure	SAF pressure
	Pressure transmitter extract air, 0...10 V DC	EAF Pressure	EAF pressure
	De-icing sensor, heat exchanger	Deicing Temp	Deicingtemp
	Frost protection sensor	Frost Protection Temp	Frost prot. temp
	Room humidity sensor	Humidity Room	Humidity room
	Duct humidity sensor	Humidity Duct	Humidity duct
	Outdoor humidity sensor	Humidity Outdoor	Humidity out
	Temperature sensor, Extra controller	Extra unit temp	Extra unit temp
	External control supply air fan	External control SAF	SAF ext. Ctrl
	External control extract air fan	External control EAF	EAF ext. Ctrl
	Pressure transmitter supply air 2	SAF Pressure 2	SAF pressure 2
	Intake temperature	Intake Temp	Intaketemp

✓	Description	E tool [®]	Display
	Extra temperature sensor 1	Extra Sensor Temp 1	Extrasensor
	Extra temperature sensor 2	Extra Sensor Temp 2	Extrasensor 2
	Extra temperature sensor 3	Extra Sensor Temp 3	Extrasensor 3
	Extra temperature sensor 4	Extra Sensor Temp 4	Extrasensor 4
	Extra temperature sensor 5	Extra Sensor Temp 5	Extrasensor 5
	Extra pressure transmitter supply air	Extra SAF Pressure	Extra SAF Pressure
	Extra pressure transmitter extract air	Extra EAF Pressure	Extra EAF Pressure
	External flow pressure transmitter	External flow setpoint	Ext sp flow

Digital input signal

✓	Description	E tool [®]	Display
	Inactive input	Not used	Not used
	Filter guard, supply air	Filter Guard 1	Filter alarm 1
	Filter guard, extract air	Filter Guard 2	Filter alarm 2
	Run-indication/alarm circulation pump, Heating	Heat Pump Indication	P1-Heating
	Run-indication/alarm circulation pump, exchanger	Exchange Pump Indication	P1-Exchanger
	Run-indication/alarm circulation pump, Cooling	Cooling Pump Indication	P1-Cooling
	Fire alarm	Fire Alarm	Fire alarm
	Fire damper end-switch monitoring	Fire Damper Indication	Fire damper-ind
	Extended operation, Normal	Extended Operation, Normal	Ext run 1/1
	Extended operation, Reduced	Extended Operation, Reduced	Ext run 1/2
	External switch	External Switch	External switch
	External alarm	External Alarm	External alarm
	Flow switch	Flow Switch	Flow guard
	Rotation guard exchanger	Exchange Rotation	Rot.sent.exch
	Run-indication/alarm supply air fan	SAF Indication	SAF-Ind
	Run-indication/alarm extract air fan	EAF Indication	EAF-Ind
	Deicing thermostat exchanger	Deicing	De-icing
	Frost protection thermostat water heater	Frost Protection	Frostprotection
	High temperature limit switch	Overheated Electric heater	Overheatprotection
	Recirculation start	Recirculation	Recirculation
	Change over	Change over	Change over

The universal inputs on Corrigo E28 can be individually configured as either analogue inputs, using any of the analogue input signals above, or as digital inputs using any of the digital inputs above.

Analogue output signal

✓	Description	E tool®	Display
	Inactive output	Not used	Not used
	Y1 Actuator Heating	Heating Y1	Y1-Heating
	Y2 Actuator Exchanger	Exchanger Y2	Y2-Exchanger
	Y3 Actuator Cooling	Cooling Y3	Y3-Cooling
	Frequency converter, supply air fan	SAF	SAF
	Frequency converter, extract air fan	EAF	EAF
	Actuator Humidity control	Dehumidification/ Humidification	Humidity
	Split of any one of temp outputs Y1, Y2, Y3 or Y1 Heating/Y3 Cooling outputs	Split	Sequence
	Extra controller	Extra unit control	ExtraUnitCtrlVa
	Y1 Heating / Y3 Cooling, Change-over output	Y1 Heating/Y3 Cooling	Y1-Heat/Y3-Cool
	Y4 Extra Sequence	Extra Sequence Y4	Y4-extra sequence
	Y5 Extra Sequence	Extra Sequence Y5	Y5-extra sequence

Digital output signal

✓	Description	E tool®	Display
	Inactive output	Not used	Not used
	Start/stop Supply air fan Normal	SAF Start 1/1 Normal Speed	SAF 1/1-speed
	Start/stop Extract air fan Normal	EAF Start 1/1 Normal Speed	EAF 1/1-speed
	Start/stop Supply air fan Reduced	SAF Start 1/2 Reduced Speed	SAF 1/2-speed
	Start/stop Extract air fan Reduced	EAF Start 1/2 Reduced Speed	EAF 1/2-speed
	Start/stop circulation pump, heating	Heating Pump Start	P1-Heating
	Fire damper	Fire Damper	Fire damper
	Sum alarm A- and B-alarm	Sum Alarm	Sum alarm
	Sum alarm A-alarm	Sum Alarm A	A-sum alarm
	Sum alarm B-alarm	Sum Alarm B	B-sum alarm
	Start/stop circulation pump, cooling	Cooling Pump Start	P1-Cooling
	Start/stop circulation pump, liquid exchanger	Exchanger Start	P1-Exchanger
	Activation-signal SAF frequency converter	SAF Freq Start	SAF-frequence
	Activation-signal EAF frequency converter	EAF Freq Start	EAF-frequence
	Activate heating	Heating Activate	Heat start
	Activate cooling	Cooling Activate	Cool start
	Activate exchanger	Exchanger Activate	Exch start
	Exhaust air close-off damper	Exhaust Air Damper	Exhaust air d
	Fresh air close-off damper	Outdoor Air Damper	Fresh air dam
	Recirculation damper	Recirculation Air Damper	Recirc. damper
	Heating 3-position actuator, increase	Heating Increase	Heat-inc

✓	Description	E tool®	Display
	Heating 3-position actuator, decrease	Heating Decrease	Heat-dec
	Exchanger 3-position actuator, increase	Exchanger Increase	Exch-inc
	Exchanger 3-position actuator, decrease	Exchanger Decrease	Exch-dec
	Cooling 3-position actuator, increase	Cooling Increase	Cool-inc
	Cooling 3-position actuator, decrease	Cooling Decrease	Cool-dec
	Step controller heating, step 1	Heat Step 1	Heat step1
	Step controller heating, step 2	Heat Step 2	Heat step2
	Step controller heating, step 3	Heat Step 3	Heat step3
	Step controller heating, step 4	Heat Step 4	Heat step4
	Step controller cooling, step 1	Cool Step 1	Cool step1
	Step controller cooling, step 2	Cool Step 2	Cool step2
	Step controller cooling, step 3	Cool Step 3	Cool step3
	Extra time channel 1	Time Channel 1	Timer 1
	Extra time channel 2	Time Channel 2	Timer 2
	Extra time channel 3	Time Channel 3	Timer 3
	Extra time channel 4	Time Channel 4	Timer 4
	Extra time channel 5	Time Channel 5	Timer 5
	Humidity	Humidity/DeHumidity	Humidity
	External controller active	Extra unit active	ExtraUnitActi
	Heating/cooling step 1	Heat/cool step 1	HeatCoolStep1
	Heating/cooling step 2	Heat/cool step 2	HeatCoolStep2
	Heating/cooling step 3	Heat/cool step 3	HeatCoolStep3
	Free cooling operation	Free cool run	Free cool run
	Pretreatment	Pretreatment	Pretreatment
	Free cooling operation	Free cool run	Free cool run
	Pretreatment	Pretreatment	Pretreatment
	Split sequence active	Split Sequence	Split sequence
	Run indication	Run indication	Run ind.
	Pulse modulated heating output	Heating PWM	Heating PWM

Wiring diagram Corrigo E28-S (default in- and output configuration)

(See also picture of terminal positions on page 13)

1	G	Supply voltage 24 V AC or 24 V DC, ±15%. 50/60 Hz
2	G0	
3		Protective earth
4	+C	+24 V DC. Reference for digital inputs DI.

50	B	RS485 EXOline / Modbus (not in WEB (TCP/IP) models)
51	A	
52	N	
53	E	

10	G _{DO}	Reference for digital outputs DO.
11	DO1	Start/stop supply air fan (SAF) 1/1-speed
12	DO2	Start/stop extract air fan (EAF) 1/1-speed
13	DO3	Start/stop supply air fan (SAF) 1/2-speed
14	DO4	Start/stop extract air fan (EAF) 1/2-speed
15	DO5	Start/stop Circulation pump, Heating
16	DO6	Fire damper
17	DO7	Sum alarm A + B

57	Net+	LON-connection (LON-versions only)
58	Net-	
59	Egnd	

30	Agnd	Reference pole for analogue inputs AI
31	AI1	Outdoor temperature sensor
32	AI2	Supply air temperature sensor
33	Agnd	Reference pole for analogue inputs AI
34	AI3	Extract air temperature sensor
35	AI4	Room temperature sensor 1

71	DI1	Filter guard, supply air and extract air
72	DI2	Run indication /alarm, Circ. pump Heating
73	DI3	Run indication /alarm, Circ. pump Cooling
74	DI4	Fire alarm
75	DI5	Fire damper end-switch monitoring
76	DI6	Extended running 1/1-speed
77	DI7	External alarm
78	DI8	External switch

40	Agnd	Reference pole for universal inputs UI
41	UI1	DI Run indication / Motor protection SAF
42	UI2	DI Run indication / Motor protection EAF
43	Agnd	Reference pole for universal inputs UI
44	UI3	De-icing sensor, heat exchanger
45	UI4	Frost protection sensor

90	Agnd	Reference pole for analogue outputs AO
91	AO1	Y1 Actuator Heating
92	AO2	Y2 Actuator Exchanger
93	AO3	Y3 Actuator Cooling
94	AO4	Not used
95	AO5	Not used

Wiring diagram Corrigo E15-S (default in- and output configuration)

1	G	Supply voltage 24 V AC or 24 V DC, ±15%. 50/60 Hz	50	B	RS485 EXOline / Modbus (not in WEB (TCP/IP) models)
2	G0		51	A	
3		Protective earth	52	N	
4	+C	+24 V DC. Reference for digital inputs DI.	53	E	
10	G _{DO}	Reference for digital outputs DO.	57	Net+	LON-connection (LON-versions only)
11	DO1	Start/stop supply air fan (SAF) 1/1-speed	58	Net-	
12	DO2	Start/stop extract air fan (EAF) 1/1-speed	59	Egnd	
13	DO3	Start/stop Circulation pump, Heating			
14	DO4	Sum alarm A + B			
30	Agnd	Reference pole for analogue inputs AI	71	DI1	Run indication / Motor protection SAF
31	AI1	Outdoor temperature sensor	72	DI2	Run indication / Motor protection EAF
32	AI2	Supply air temperature sensor	73	DI3	Run indication /alarm, Circ. pump Heating
33	Agnd	Reference pole for analogue inputs AI	74	DI4	Extended running
34	AI3	Frost protection sensor			
35	AI4	Room temperature sensor 1			
90	Agnd	Reference pole for analogue outputs AO	90	Agnd	Reference pole for analogue outputs AO
			91	AO1	Y1 Actuator Heating
			92	AO2	Y2 Actuator Exchanger
			93	AO3	Y3 Actuator Cooling

Wiring diagram Corrigo E8-S (default in- and output configuration)

1	G	Supply voltage 24 V AC or 24 V DC, ±15%. 50/60 Hz	50	B	RS485 EXOline / Modbus (not in WEB (TCP/IP) models)
2	G0		51	A	
3		Protective earth	52	N	
4	+C	+24 V DC. Reference for digital inputs DI.	53	E	
10	G _{DO}	Reference for digital outputs DO.	57	Net+	LON-connection (LON-versions only)
11	DO1	Start/stop supply air fan (SAF) 1/1-speed	58	Net-	
12	DO2	Start/stop Circulation pump, Heating	59	Egnd	
30	Agnd	Reference pole for analogue inputs AI	71	DI1	Run indication / Motor protection SAF
31	AI1	Outdoor temperature sensor	72	DI2	Run indication /alarm, Circ. pump Heating
32	AI2	Supply air temperature sensor	73	DI3	High temp. limit switch / Frost prot. thermostat
90	Agnd	Reference pole for analogue outputs AO	90	Agnd	Reference pole for analogue outputs AO
			91	AO1	Y1 Actuator Heating

Empty wiring diagram Corrigo E28-S

1	G	Supply voltage 24 V AC or 24 V DC, ±15%. 50/60 Hz
2	G0	
3		Protective earth
4	+C	+24 V DC. Reference for digital inputs DI.

50	B	RS485 EXOline / Modbus (not in WEB (TCP/IP) models)
51	A	
52	N	
53	E	

10	G _{DO}	Reference for digital outputs DO.
11	DO1	
12	DO2	
13	DO3	
14	DO4	
15	DO5	
16	DO6	
17	DO7	

57	Net+	LON-connection (LON-versions only)
58	Net-	
59	Egnd	

30	Agnd	Reference pole for analogue inputs AI
31	AI1	
32	AI2	
33	Agnd	Reference pole for analogue inputs AI
34	AI3	
35	AI4	

71	DI1	
72	DI2	
73	DI3	
74	DI4	
75	DI5	
76	DI6	
77	DI7	
78	DI8	

40	Agnd	Reference pole for universal inputs UI
41	UI1	
42	UI2	
43	Agnd	Reference pole for universal inputs UI
44	UI3	
45	UI4	

90	Agnd	Reference pole for analogue outputs AO
91	AO1	
92	AO2	
93	AO3	
94	AO4	
95	AO5	

Empty wiring diagram Corrigo E15-S

1	G	Supply voltage 24 V AC or 24 V DC, ±15%. 50/60 Hz
2	G0	
3		Protective earth
4	+C	+24 V DC. Reference for digital inputs DI.

50	B	RS485 EXOline / Modbus (not in WEB (TCP/IP) models)
51	A	
52	N	
53	E	

10	G _{DO}	Reference for digital outputs DO.
11	DO1	
12	DO2	
13	DO3	
14	DO4	

57	Net+	LON-connection (LON-versions only)
58	Net-	
59	Egnd	

30	Agnd	Reference pole for analogue inputs AI
31	AI1	
32	AI2	
33	Agnd	Reference pole for analogue inputs AI
34	AI3	
35	AI4	

71	DI1	
72	DI2	
73	DI3	
74	DI4	

90	Agnd	Reference pole for analogue outputs AO
91	AO1	
92	AO2	
93	AO3	

90	Agnd	Reference pole for analogue outputs AO
91	AO1	
92	AO2	
93	AO3	

Empty wiring diagram Corrigo E8-S

1	G	Supply voltage 24 V AC or 24 V DC, ±15%. 50/60 Hz
2	G0	
3		Protective earth
4	+C	+24 V DC. Reference for digital inputs DI.

50	B	RS485 EXOline / Modbus (not in WEB (TCP/IP) models)
51	A	
52	N	
53	E	

10	G _{DO}	Reference for digital outputs DO.
11	DO1	
12	DO2	

57	Net+	LON-connection (LON-versions only)
58	Net-	
59	Egnd	

30	Agnd	Reference pole for analogue inputs AI
31	AI1	
32	AI2	

71	DI1	
72	DI2	
73	DI3	

90	Agnd	Reference pole for analogue outputs AO
91	AO1	

Empty wiring diagram Corrigo E282-S

1	G	Supply voltage 24 V AC or 24 V DC, ±15%. 50/60 Hz
2	G0	
3		Protective earth
4	+C	+24 V DC. Reference for digital inputs DI.

50	B	RS485 EXOline / Modbus (Port 1)
51	A	
52	N	
53	E	

10	G _{DO}	Reference for digital outputs DO.
11	DO1	
12	DO2	
13	DO3	
14	DO4	
15	DO5	
16	DO6	
17	DO7	

54	B	RS485 EXOline / Modbus (Port 2)
55	A	
56	N	
57	E	

30	Agnd	Reference pole for analogue inputs AI
31	AI1	
32	AI2	
33	Agnd	Reference pole for analogue inputs AI
34	AI3	
35	AI4	

71	DI1	
72	DI2	
73	DI3	
74	DI4	
75	DI5	
76	DI6	
77	DI7	
78	DI8	

40	Agnd	Reference pole for universal inputs UI
41	UI1	
42	UI2	
43	Agnd	Reference pole for universal inputs UI
44	UI3	
45	UI4	

90	Agnd	Reference pole for analogue outputs AO
91	AO1	
92	AO2	
93	AO3	
94	AO4	
95	AO5	

Empty wiring diagram Corrigo E152-S

1	G	Supply voltage 24 V AC or 24 V DC, ±15%. 50/60 Hz
2	G0	
3		Protective earth
4	+C	+24 V DC. Reference for digital inputs DI.

10	G _{DO}	Reference for digital outputs DO.
11	DO1	
12	DO2	
13	DO3	
14	DO4	

30	Agnd	Reference pole for analogue inputs AI
31	AI1	
32	AI2	
33	Agnd	Reference pole for analogue inputs AI
34	AI3	
35	AI4	

50	B	RS485 EXOline / Modbus (Port 1)
51	A	
52	N	
53	E	
54	B	RS485 EXOline / Modbus (Port 2)
55	A	
56	N	
57	E	

71	DI1	
72	DI2	
73	DI3	
74	DI4	

90	Agnd	Reference pole for analogue outputs AO
91	AO1	
92	AO2	
93	AO3	

Chapter 4 Commissioning

General

Before the Corrigo can be used, all inputs and outputs must first be configured, as well as all relevant parameters.

All commissioning can be done using the Corrigo front panel display and buttons or using the display unit E-DSP.

E tool[®]

The best way however, is to configure the Corrigo E by using E tool[®].

E tool[®] is a PC-based configuration program specially developed to simplify the commissioning of the Corrigo E series.

When using E tool[®] the whole configuration and all settings can be done on the computer and then be downloaded to the Corrigo. An infinite number of different configurations can be saved in computer memory for later use.

A communication cable is required in order to configure Corrigo E. E-CABLE-USB, E-CABLE2-USB or E-CABLE-RS232 are used for controllers featuring RS485 communication, and E-CABLE-TCP/IP for controllers with a TCP/IP port.

The Corrigo must be powered up and the application selected in order for it to be configured.

4.1 How to do it

For configuration using E tool[®], see the E tool[®] manual.

For configuration using the front panel there are two ways to go depending on how much help you need.

Option 1:

- Jump straight to chapter 7 and 8, *Display, LEDs and buttons* and *Access rights*.
- After learning how to use the buttons and menu system, connect power to your Corrigo, log on as Admin and go to the menu "Configuration".
- For the time being, skip the configuration menu In-/Outputs and start by configuring control functions.
- Run through the configuration menus in order and set whatever functions and parameters you wish to include. Use chapter 6 of this manual for reference. Keep track of which inputs and outputs you will need. To help you, there is a list of input and output functions provided in chapter 3, (3.2.3 Input / Output list.)
- Finally, configure In-/Outputs.
- Exit the "Configuration" menu and go to "Settings".
- Set the control values in "Settings".
- Set the clock and scheduler functions in "Time Settings".
- Set the control setpoints in temperature and air control as well as in humidity control if humidity control has been configured

Your Corrigo should now be ready to run.

Option 2:

Read this manual in the order given below: The manual has been designed to act as a guide through the commissioning. The last chapters of the manual, not listed below, cover menus and functions that are not used during commissioning.

Functional description

Start by reading chapter 5. *Functional description* below. Some functions are essential to the working of the unit and must be included. Others are more of the nature of optional extras which can be excluded.

At the end of each function description there is a table of the necessary inputs and outputs to implement the function. At the end of the manual there is a list of all the analogue and digital inputs and outputs. As you read, mark in the list the inputs and outputs you will be using for the application you are building. Note that the universal inputs in Corrigo E28 can, individually, be configured as either analogue or digital inputs.

Display, buttons and LEDs

Read chapter 7 on how to use the front panel buttons to navigate the Corrigo E menu system.

Access rights

Chapter 8. Learn how to log on to the Corrigo E.

Configuration

Chapter 16. Configuration.

Connect power to the Corrigo. Using the buttons and menu system, go through the configuration menus covering the functions you wish to use.

On delivery the units already have the inputs and outputs assigned to various functions. These can, of course, be changed. In chapter 3 *Installation and wiring* there are two sets of wiring diagrams, one set showing the pre-configured input / output configuration and one set where you can fill your own configuration choices.

Settings

Chapter 15

Set the control parameters, P-band, I-time for the temperature control.

Set the control parameters for the pressure control if you have pressure- or flow- controlled fans.

Set the control parameters for the humidity control if activated.

Set the alarm parameters; alarm levels and delay times.

Time settings

Chapter 13

Set the clock and calendar functions.

Setpoints

Chapters 10, 11 and 12:

Set all the setpoints for all active control loops.

Manual/Auto

Chapter 14

Learn to use manual control. Very useful for testing out your system.

Other functions

Chapter 18

Alarm handling etc.

Chapter 5 Functional description

5.1 Temperature control

General

Corrigo E has a choice of the following control modes:

1. Supply air control
2. Outdoor temperature compensated supply air control
3. Cascaded room temperature control
4. Cascade connected extract air temperature control
5. Outdoor temperature dependent switching between supply air control and room temperature control
6. Outdoor temperature dependent switching between supply air control and extract air control
7. Outdoor compensated room temperature control
8. Outdoor compensated extract air control

The supply air temperature controller is reverse acting, i. e. the output will increase for decreasing temperature. The controller is a PI-controller with settable P-band and I-time.

In the first two modes the supply air temperature will be controlled using the supply air temperature and the user setpoint values as control inputs.

In modes three and four the supply air is controlled as part of a cascade controller together with the room/extract temperature controller. The room/extract temperature offset will dictate the supply air temperature setpoint.

Mode five and six vary according to the outdoor temperature: Supply air control in winter and cascaded room control or cascaded extract air control in summer.

In applications with mixing dampers instead of heat exchanger the signal for the damper control will be reversed compared to the signal for heat exchanger control i. e. decreasing signal on increasing heat demand. This is done automatically on configuring the exchanger output = dampers.

The heater can be either a hot water heater battery or an electric heater.

Outputs

The supply air controller output is split between one or more of the output blocks "Heating Y1", "Exchanger Y2" and "Cooling Y3". Each of these output blocks can be bound to either an analogue 0...10 V DC output or to two digital 3-position increase/decrease outputs.

Each output block has two parameters for setting the control range:

Heating Controller Output signal (HCO_{out}) at which the output should be 0 %

Heating Controller Output signal (HCO_{out}) at which the output should be 100 %

These settings are used to establish the output activation order and to split the P-band between the outputs.

Example:

0 % Cooling at HCO_{out} = 30 %

100 % Cooling at HCO_{out} = 0 %

0 % heat exch. at HCO_{out} = 32 %

100 % heat exch. at HCO_{out} = 50 %

0 % Heating at HCO_{out} = 54 %

100 % Heating at HCO_{out} = 100 %

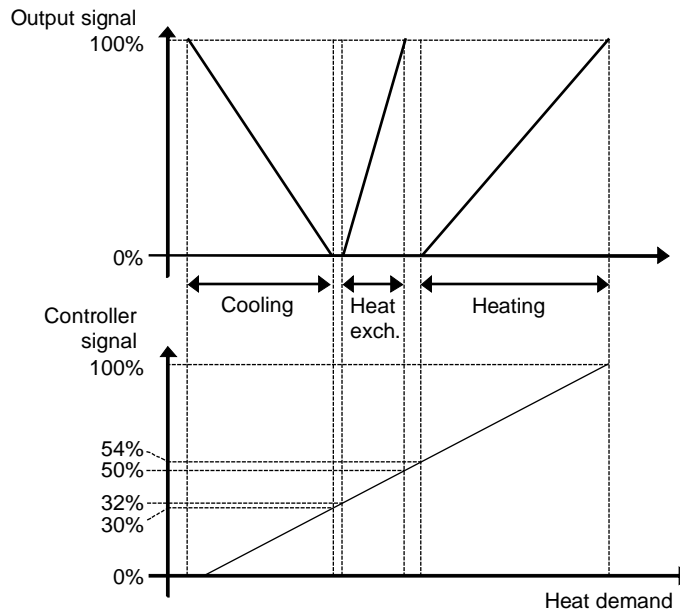

In addition to these three, it is possible to connect two additional analogue output signals for control of optional sequences, Y4 Extra sequence and Y5 Extra sequence. "Y4 Extra sequence" and "Y5 Extra sequence" are both set in the same way as above. It is also possible to select whether "Y4 Extra sequence" should be affected by the enthalpy control and/or the cooling recovery.

A change-over signal can also be configured, "Y1 Heating/Y3 Cooling".

0 % at HCO_{out} = 0 % (HCO_{out}= Heating Controller Output)

100 % at HCO_{out} = 0 %

It is also possible to split one of the three analogue outputs Heating, Heat exchanger or Cooling into two equal parts if an additional output function is desired.

Y4 Extra sequence and Y1 Heating/Y3 Cooling can also be split.

There is also a pulse-width modulated digital output, "Heating PWM".

Its period time is settable with a default setting of 60 s.

Example:

With a controller output of 50 % and a period time of 60 s, the output will be on for 30 s and off for 30 s. With a controller output of 25 % the output will be on for 15 s and off for 45 s.

5.1.1 Control modes

1. Supply air control

The supply air temperature is kept at the setpoint value by controlling the output signals for "Heating Y1", "Exchanger Y2", "Cooling Y3", "Extra sequence Y4" and "Extra sequence Y5". A single PI control loop is used.

The setpoint value is set using the front panel or alternatively using an external setpoint device.

Alarms which are activated when the supply air temperature is too high or too low are active.

Alarm for control offset of the supply air temperature is active.

2. Outdoor temperature compensated supply air control

The supply air temperature setpoint is outdoor temperature compensated using a control curve with 6 node points.

The supply air temperature is kept at the setpoint value by controlling the output signals for "Y1 Heating", "Y2 Heat exchanger", "Y3 Cooling", "Extra sequence Y4" and "Extra sequence Y5". A single PI control loop is used.

Alarms which are activated when the supply air temperature is too high or too low are active.

Alarm for control offset of the supply air temperature is active.

3. Cascaded room temperature control

Cascade control of room temperature and supply air temperature to achieve a constant, settable room temperature. The room controller output signal generates the supply air controller's setpoint value.

One or two room sensors can be connected. If two sensors are connected the average of their values will be used. The number of room sensors is detected automatically. The room temperature is kept at the setpoint value by controlling the output signals for "Y1 Heating", "Y2 Heat exchanger", "Y3 Cooling", "Extra sequence Y4" and "Extra sequence Y5". Two PI loops are used.

The room setpoint value is set using the front panel or alternatively using an external setpoint device.

4. Cascaded extract air temperature control

Cascade control of extract air temperature and supply air temperature to achieve a constant, settable room temperature. The extract air controller output signal generates the supply air controller's setpoint value.

The extract air temperature is kept at the setpoint value by controlling the output signals for "Y1 Heating", "Y2 Heat exchanger", "Y3 Cooling", "Extra sequence Y4" and "Extra sequence Y5". Two PI loops are used.

The extract air setpoint value is set using the front panel or, alternatively, by using an external setpoint device.

5. Outdoor temperature dependent switching between supply air temperature control and room temperature control

When the outdoor temperature is lower than a settable limit (winter), outdoor compensated supply air temperature control will be active, otherwise (summer) cascaded room temperature control.

6. Outdoor temperature dependent switching between supply air temperature control and extract air temperature control

When the outdoor temperature is lower than a settable limit (winter), outdoor compensated supply air temperature control will be active, otherwise (summer) cascaded room temperature control as in control mode 4.

7. Outdoor compensated room temperature control

The room temperature can be compensated when the outdoor temperature increases. One can, for instance, imagine accepting a slightly higher room temperature if it is warm outside or, conversely, a slightly lower temperature if it is chilly. This function is included to conserve energy.

8. Outdoor compensated extract air control

The extract air temperature can be compensated when the outdoor temperature increases. One can, for instance, imagine accepting a slightly higher extract air temperature if it is warm outside or, conversely, a slightly lower extract air temperature if it is chilly. This function is included to conserve energy.

In- and outputs

1	2	3	4	5	6	7	8	Control mode
AI	AI	AI	AI	AI	AI	AI	AI	Supply air sensor
	AI			AI	AI	AI	AI	Outdoor temperature sensor
		AI		AI		AI		Room sensor
			AI		AI		AI	Extract air sensor
AO	AO	AO	AO	AO	AO	AO	AO	Y1 Heating 0...10 V DC **
AO	AO	AO	AO	AO	AO	AO	AO	Y2 Exchanger 0...10 V DC **
AO	AO	AO	AO	AO	AO	AO	AO	Y3 Cooling 0...10 V DC **
AO	AO	AO	AO	AO	AO	AO	AO	Y4 Extra sequence 0...10 V DC
AO	AO	AO	AO	AO	AO	AO	AO	Extra split Y1, Y2 or Y3 0...10 V DC (optional)
AO	AO	AO	AO	AO	AO	AO	AO	Y1 Heating/Y3 Cooling Change-over (option)
DO	DO	DO	DO	DO	DO	DO	DO	Heating 3-pos. increase **
DO	DO	DO	DO	DO	DO	DO	DO	Heating 3-pos. decrease **
DO	DO	DO	DO	DO	DO	DO	DO	Exch. 3-pos. increase **
DO	DO	DO	DO	DO	DO	DO	DO	Exch. 3-pos. decrease **
DO	DO	DO	DO	DO	DO	DO	DO	Cooling 3-pos. increase **
DO	DO	DO	DO	DO	DO	DO	DO	Cooling 3-pos. decrease **

** Choose output type depending on the actuator type: Either AO 0...10 V or DO 3-position increase/decrease.

5.1.2 Heater types

5.1.2.1 Water heating

Control

When the unit is in running mode the heating valve is controlled by the analogue output "Y1 Heating" or by two digital outputs "Heating 3-pos. actuator, increase" and "Heating, 3-pos. actuator, decrease".

Frost protection

The heater return water temperature is measured using the analogue input "Frost prot.temp". Low temperatures will generate an internal, proportional signal that is used to force the heating valve open thereby preventing freeze-up of the heater.

The internal signal ("Internal signal") will begin to rise as the frost protection temperature falls below "Alarm level" + "Prop. Band" in order to reach 100 % output when the signal has fallen to "Alarm level".

When "Internal signal" reaches 100 % or the digital input "Deicing Heat exchanger" is activated, the unit is shut down, the heating output is set to completely open mode and an alarm is activated. The unit is restarted when the alarm has been acknowledged and the temperature for the frost protection sensor has risen above "Alarm limit frost" + "P-Band".

Frost protection control is available on Y1 Heating, Y4 Extra sequence or on both Y1 and Y4.

The frost protection alarm level is set in the menu *Settings/Alarm settings/Alarm limit*.

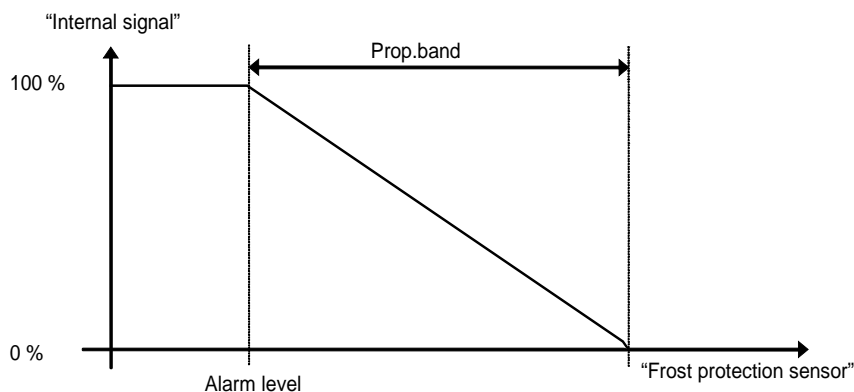

Shutdown mode

If frost protection is activated the controller will go into "Shutdown mode" when the running mode switches to "Off". The shutdown controller will control the heating output to maintain a constant settable temperature at the frost protection sensor.

5.1.2.2 Electric heating

Control

The heating is controlled using the analogue output "Y1 Heating". On activation of the digital input "High temp limit switch" the unit will be shut down, either according to the stop sequence described in section *Start/stop of unit* or as an emergency shutdown. The unit will restart after the alarm has been acknowledged and "High temp limit switch" has reset. Note that activation of the input signal "Flow switch" will also stop the unit.

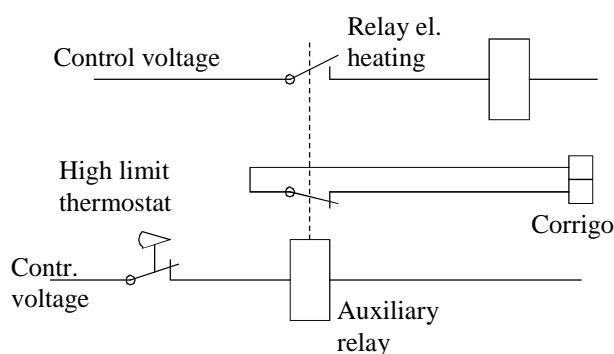

Wiring suggestion high temp limit when using electric heating.

Contactors drawn **inactivated**.

Note: It is important that the high temperature thermostat is hardwired to disconnect the power to the heater to ensure that the heating is shut down when the thermostat is activated even if the Corrigo should be faulty.

5.1.2.3 Water heating and electric heating

The water heating is controlled by "Y1 Heating", and the electric heating is controlled by the sequence "Split". Split (see the section Split of optional temp sequence) must always be set to "Heating". On increasing heat demand, the water heating is first activated and then, if needed, the electric heating.

Frost protection and overheating protection are both active. If "step controller heating" is used, the function is tied to the output signal "Split".

5.1.2.4 Fast stop on overheating

If the function "fast stop on overheating" is active, the fans will be immediately stopped when there is an overheating alarm, regardless of the set cool-down time.

In- and outputs

Water heating	Electric heating	
AI		Frost protection sensor (optional)
DI**		Frost protection thermostat water heater (optional)
	DI	High temperature limit switch
	DI	Flow switch (optional)

**Frost protection can also be created using the digital input "Frost protection thermostat water heater" and an external thermostat. Activation of the input will force the running mode to Off and an alarm will be activated. The heating output is set to completely open, the remaining control outputs are set to zero.

Frost protection thermostat cannot be combined with shutdown mode.

5.1.3 Heat exchangers

The heat exchanger unit can be set to one of the following alternatives:

- Plate exchanger
- Rotating exchanger
- Liquid connected exchanger
- Mixing dampers

Plate exchanger

Control

The airflow through the exchanger is controlled by a shut-off damper and a by-pass damper. Both dampers are controlled by the same analogue output "Y2 Heat exchanger" or by two digital outputs "Exchanger 3-pos. actuator, increase" and "Exchanger, 3-pos. actuator, decrease", and are wired so that one opens as the other closes.

De-icing

De-icing is activated either when the digital input signal "De-icing exchanger" is activated or when the value of the analogue input "Deicingtemp" falls below the de-icing limit (-3°C). It is deactivated when the digital input is reset or the analogue input rises above the limit value plus a settable differential.

On de-icing:

A PI-controller compares the de-icing setpoint with the signal "De-icing Exchanger". The lesser of the output signal from this controller and the output from the ordinary controller is used as output to the dampers.

Rotating exchanger

Control

Rotational speed is controlled by the analogue signal "Y2 Heat exchanger" or by two digital outputs "Exchanger 3-pos. actuator, increase" and "Exchanger, 3-pos. actuator, decrease". A rotation sentinel can be connected to the digital input "Rotation sentinel Exchanger". An alarm is generated if this input is activated at the same time as the analogue output signal is higher than 1.0V.

Liquid connected exchanger

Control

A mixing valve in the exchanger circulation system is controlled by the analogue signal "Y2 Heat exchanger" or by two digital outputs "Exchanger 3-pos. actuator, increase" and "Exchanger, 3-pos. actuator, decrease".

The circulation pump (digital output "Start/stop circulation pump, liquid exchanger") is started as soon as the actuator control signal exceeds 0.1 V and is stopped when the valve has been closed for more than 5 minutes.

De-icing

De-icing is activated either when the digital input signal "De-icing exchanger" is activated or when the value of the analogue input "Deicingtemp" falls below the de-icing limit (-3°C). It is deactivated when the digital input is reset or the analogue input rises above the limit value plus a settable differential.

On de-icing:

A PI-controller compares the de-icing setpoint with the signal "De-icing Exchanger". The lesser of the output signal from this controller and the output from the ordinary controller is used as output to the actuator.

Outdoor temp control of exchanger

Instead of using Y2 for analogue control of the heat exchanger it can be set to run on-off against outdoor temperature. The function controls a digital output "Exch control", which is activated when the outdoor temperature falls below a set value.

Mixing dampers

Control

The analogue output signal "Exchanger Y2", or the two digital output signals "Exchanger 3-position, increase" and "Exchanger 3-position, decrease", control two dampers for gradual mixing of outdoor air and recirculated air. In this mode the output signal decreases with increasing heat demand.

CO₂

If demand controlled ventilation (see 5.4.2) is activated in combination with mixing dampers, and the CO₂-value rises above the setpoint value, the dampers will let in more outdoor air. The function is controlled by a PI-controller. Factory settings: P-band 100ppm and I-time 100 seconds. These values can only be changed in E tool[®].

CO₂/VOC control can be used on "Y2 Exchanger" or "Y4 Extra sequence". The control is selectable for use on Y2, Y4 or on both outputs.

Minimum limit

An outdoor air minimum limit for can be set using the front panel. The limit value is settable between 0 and 100 %.

In- and outputs

Plate	Rotating Exch.	Liquid	Dampers	
AI	AI	AI	AI	Outdoor temp. sensor (optional, outd. temp start)
DO	DO	DO	DO	Activate exchanger (optional, outd. temp start)
AI		AI		De-icing sensor (optional)
DI		DI		De-icing signal (optional)
	DI			Rotation sentinel (optional)

Start delay exchanger

This function delays the exchanger start at start-up of the unit.

100 % exchanger output at start-up

After the delay described above, the exchanger output will be 100 % during the set time.

5.1.4 Types of chillers

Step controller Heating / DX cooling

As alternative or complement to the above mentioned analogue control, heating and cooling can be activated in steps. The internal signal is then used to activate digital outputs for control of the heaters/chillers. Up to four heater outputs and three cooler outputs can be configured. There are two possible modes:

Sequential

Each output step has individually settable on and off values in percent of the control signal. The number of steps is equal to the number of heater/chiller groups. Minimum on and off times can be set, i.e. the minimum time the step has to be inactive or active for a change to occur.

Binary

The heater power outputs should be binary weighted (1:2:4:8 for heating, 1:2:4 for cooling). The number of loads to be controlled is set. Thereafter the program will automatically calculate the individual activation levels. Switching differential and minimum on/off times can be set. The number of heating steps will be: $2^{\text{no. of groups}} - 1$. In binary mode, the analogue output signal may be used to fill out between the steps. The signal will go 0...100 % between the activation of each step. The load connected to the analogue signal should have the same size as the smallest of the binary groups. In the example below there are 4 heater groups (1:1:2:4) and the total number of heating steps is eight.

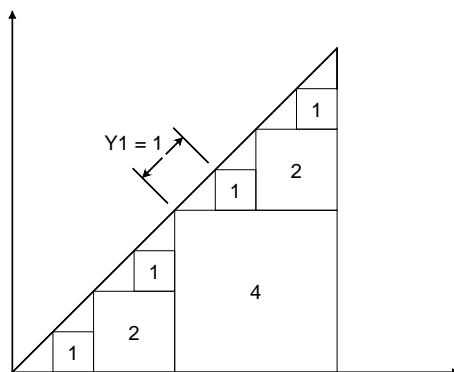

Step controllers and Change-over

The digital output signals "Heating/cooling step 1", "Heating/cooling step 2" and "Heating/cooling step 3" are used for step controllers during Change-over control (see section 5.1.12). They have the same functions as other step controller outputs, but are set to either heating or cooling depending on whether heating or cooling is required.

DX cooling with room or extract air control

If DX cooling is used in conjunction with room temperature control or extract air temperature control, there are two configuration alternatives, DX cooling or DX cooling with exchanger control.

DX cooling without exchanger control

When running cascade control, the supply air controller setpoint is normally controlled by the room/extract air controller output signal.

When DX cooling is activated, the supply air controller setpoint is lowered to five degrees (adjustable) below the setpoint given by the room/extract air controller. This prevents the DX cooling from being activated/deactivated too often.

DX cooling with exchanger control

When running cascade control, the supply air controller setpoint is normally controlled by the room/extract air controller output signal.

When DX cooling is activated, the supply air controller setpoint is lowered to five degrees (adjustable) below the setpoint given by the room/extract air controller. This prevents the DX cooling from being activated/deactivated too often. If the supply air temperature falls below the setpoint given by the room/extract air controller, the heat exchanger output will be activated in order to try to maintain the supply air setpoint given by the room/extract air controller. The output uses P-control with a P-band of half the setpoint lowering (adjustable, 2.5°C as default). The setpoint given by the room/extract air controller cannot drop below the set min limit. When there is no longer a cooling demand, the supply air controller setpoint will return to the value given by the room/extract air controller.

Note: The function cannot be used if the exchanger signal controls a mixing damper.

Example:

The room controller gives a supply air setpoint of 16°C. If there is a cooling demand, the supply air controller setpoint is lowered to 11°C (16 – 5) and DX cooling is activated. Should the supply air temperature fall below 16°C, the exchanger output will be activated and reach 100 % output when the supply air temperature has fallen to 13.5°C (16 - 2.5).

Blocking of DX cooling at low outdoor temperature

DX cooling can be blocked when the outdoor temperature is low. It is possible to block the three cooling steps individually or to block all DX cooling. The temperature limits are adjustable (+13°C default) and have a fixed one degree hysteresis.

When two DX cooling steps are used with binary function, the cooling effect is divided into three steps. The desired blocking level can be set individually for each of these steps.

When three DX cooling steps are used with binary function, the cooling effect is divided into seven steps. However, the controller still only has three blocking level settings. Therefore, Blocking step 1 will apply to binary steps 1 and 2, Blocking step 2 to binary steps 3 and 4, and Blocking step 3 to binary steps 5, 6 and 7.

Blocking of DX cooling at low supply air fan speed

When DX cooling is used in conjunction with pressure controlled or flow controlled fans it is possible to block DX cooling if the supply air fan control signal falls below a preset values. For sequential control, the blocking level is individually settable for each DX cooling step.

When two DX cooling steps are used with binary function, the cooling effect is divided into three steps. The desired blocking level can be set individually for each of these steps.

When three DX cooling steps are used with binary function, the cooling effect is divided into seven steps. However, the controller still only has three blocking level settings. Therefore, Blocking step 1 will apply to binary steps 1 and 2, Blocking step 2 to binary steps 3 and 4, and Blocking step 3 to binary steps 5, 6 and 7.

Blocking of DX cooling on cooling pump alarm

Corrigo can be configured to block DX cooling on cooling pump alarm.

In- and outputs

Heating	Cooling	Heating/Cooling Change-over	
DO	DO	DO	Step controller, step 1 (optional)
DO	DO	DO	Step controller, step 2 (optional)
DO	DO	DO	Step controller, step 3 (optional)
DO			Step controller, step 4 (optional)

Override of reduced speed for DX cooling

Override to normal quantity of air for DX cooling when the unit runs on reduced quantity of air. The fans can be set to normal operation when cooling is required at high outdoor temperatures (e.g. >14°C, the same temperature limit as for blocking of DX cooling).

5.1.5 Support control

Support control is normally used when room temperature control or extract air control has been configured. When extract air control is configured a room sensor must be installed. "Support control Heating" or "Support control Cooling" will run if Support control is configured, the running mode is in Off-state (timer control OFF and not in extended running) and if conditions call for support control (see below). Minimum run time is settable 0 to 720 minutes (FS= 20 minutes).

Support control can also be configured when supply air temperature control is used, if a room sensor is installed. The controller uses the configured min. (FS=15°C) and max. (FS=30°C) limitation values as support control setpoints. However, in this case the min. and max. limitation values cannot be changed. To change the values, temporarily configure room control, change the min. and max. values and then change back to supply air control.

Support control can also be configured to start only with the supply air fan. In this mode, the extract air fan is not active. This requires a digital output to be configured, which controls the recirculation damper to open completely so the supply air fan can circulate the air to and from the room. The digital output is called "recirculation damper".

Support control heating

Demand for support control heating is when the room temperature is lower than the start value which is settable 0 to 30°C. The fans will run at the preset speed, the heater and the heat exchanger are controlled by the supply air temperature controller with the configured max limitation for the supply air (FS=30°C) as setpoint and the cooling is shut off (0%). Support control heating stops when the room temperature rises to the stop value and the minimum run time has been exceeded or the running mode changes to "On".

Support control cooling

Demand for support control cooling is when the room temperature is higher than the start value which is settable 20 to 50°C. The fans will run at the preset speed, the heater and the heat exchanger are shut down (0 %) and the cooling is controlled by the supply air temperature controller with the configured minimum limitation (FS=15°C) as setpoint. Support control cooling stops when the temperature falls below the stop value and the minimum run time has been exceeded or the running mode changes to "On".

5.1.6 Free cooling

This function is used during the summer to cool the building night-time using cool outdoor air, thereby reducing the need for cooling during the day and saving energy.

Free cooling requires an outdoor sensor (or an inlet temperature sensor) and either a room sensor *or* an extract air sensor. The outdoor sensor can be placed in the fresh air inlet duct.

Free cooling is only activated when all the start conditions are fulfilled.

Start conditions:

- Less than four days have passed since the unit was last in running mode.
- The outdoor temperature during the previous running period exceeded a set limit (22°C).
- It is between 00:00 and 07:00:00 in the day (settable).
- The timer outputs for "normal speed", "Extended running, Normal" and "External switch" are Off.
- A timer channel will be On sometime during the recently started 24 hours.

If the outdoor sensor is located in the fresh air inlet duct and/or an extract air sensor is selected and ALL the start conditions are fulfilled, free cooling is activated and will run for 3 minutes to ensure that the temperature measurement when using an extract air sensor reflects the corresponding room temperature and that the outdoor temperature sensor senses the outdoor temperature even if it is placed in the fresh air inlet duct. If the outdoor sensor is not located in the fresh air inlet duct and a room sensor is selected, the unit will not start free cooling as long as all the temperatures are not within the start and stop temperature intervals.

After three minutes, the stop conditions will be controlled.

Stop conditions:

- Outdoor temp above the set max. value (18°C) or below the set min. value (condensation risk, 10°C).
- The room temp/extract air temp. is below the set stop value (18°C).
- The timer outputs for "normal speed", "Extended running, Normal" or "External switch" are On.
- It is past 07:00:00 in the day.

If any stop condition is fulfilled after three minutes, the unit will stop again. Otherwise, operation will continue until a stop condition is fulfilled.

When free cooling is active, the fans run at normal speed or the set value for pressure/flow control and the digital output "Free cooling operation" is active. The outputs "Y1-Heating", "Y2-Heat exchanger" and "Y3-Cooling" are shut down. After free cooling has been active, the heating output is blocked for 60 minutes (configurable time).

In- and outputs

AI	Outdoor temperature sensor <i>or</i> Intake temperature
AI	Room sensor <i>or</i> Extract air sensor
DO	Free cooling operation

5.1.7 Cooling recovery

If the extract air temperature is a settable amount lower than the outdoor temperature, cooling recovery can be activated. When cooling recovery is activated the heat exchanger signal will be reversed to give increasing recovery on increasing cooling demand. The function also activates the heating function "Free heating": if heating is required and the outdoor temperature is higher than the extract air temperature, outdoor air will primarily be used.

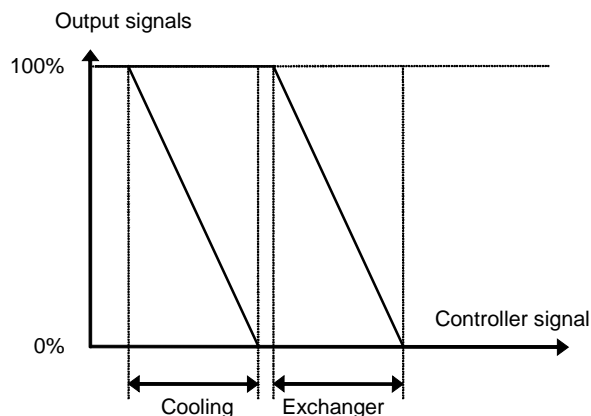

In- and outputs

AI	Outdoor temperature sensor
AI	Extract air sensor

5.1.8 Enthalpy control

Calculating the enthalpy means to calculate the energy content of the air, taking into consideration both the temperature and the air humidity. The value is given in energy per kilogram air (kJ/kg). If enthalpy control is configured, the enthalpy is calculated both indoors and outdoors. If the enthalpy is higher outdoors than indoors, the recirculation damper will be overridden to increase the recirculation. The function is not active when using free cooling, in this case outdoor air is used for cooling the room instead. For the enthalpy calculation to be made, four sensors are required:

In- and outputs

AI	Outdoor temperature sensor
AI	Outdoor humidity sensor
AI	Room/Extract air temperature sensor
AI	Room humidity sensor

5.1.9 Heat exchanger efficiency monitoring

General

The function calculates the heat exchanger temperature efficiency in percent when the output signal to the exchanger is higher than 5 % and the outdoor temperature is lower than 10°C.

When the control signal is lower than 5 % or the outdoor temperature is higher than 10°C the display will show 0 %.

The heat exchanger efficiency is calculated using the following formula:

$$\text{Efficiency} = (\text{Extractairtemp} - \text{Exhaustairtemp}) / (\text{Extractairtemp} - \text{Outdoortemp}) * 100$$

Alarm

An alarm is activated if the efficiency falls below the set alarm level (50 %).

In- and outputs

AI	Outdoor temperature sensor
AI	Extract air sensor
AI	Exhaust air sensor

5.1.10 External setpoint

An external setpoint device, e.g. TBI-PT1000 or TG-R4/PT1000 can be connected. The setpoint device must follow the PT1000 resistance curve. The unit is connected to the analogue input signal "Extra temperature sensor 1". The function must be activated in the menu "Configuration/External setpoint". The setting range can be min/max limited via a setting in the controller. The factory setting is min: +12, max: +30.

In- and outputs

AI	Extra temperature sensor 1
----	----------------------------

5.1.11 Recirculation

Recirculation is a function for distributing the air in the room using the supply air fan. The function can be used even when there is no heating or cooling demand. When using recirculation control, the extract air fan stops and a recirculation damper opens which allows the air to circulate through the unit.

Recirculation is activated either via a digital input signal or by connecting it to "Timer output 5". If timer output for normal/reduced speed is activated during recirculation via "Timer output 5", normal/reduced speed gets priority. If timer output for normal/reduced speed is activated during recirculation via a digital input, recirculation gets priority.

Recirculation control can be configured as either air circulation (temperature control inactive) or air circulation with temperature control. (Only heating, only cooling or both heating and cooling). Recirculation control has its own setpoint. However, the other settings are the same as for normal operation, i. e. if normal operation has been configured as room control, room control will also be used during recirculation.

The recirculation setpoint can be configured as constant or offset. Constant means that the recirculation setpoint will be used. Offset is based on an offset from the supply air setpoint.

To lower the temperature, it is possible to configure free cooling to be used during recirculation, if the conditions for free cooling are fulfilled. Then, the recirculation damper closes, the supply and extract air dampers open and the extract air fan starts (the supply air fan also starts, if it is not already running). If the free cooling function is not configured for recirculation control and you want to cool down the supply air via a low recirculation setpoint, the cooling battery will be used. A max. room temperature can be configured for recirculation control. If the room temperature rises above the set value (FS 25°C), recirculation will be stopped. When the room temperature has fallen 1 K below the set max limit, recirculation will start again if the start conditions are still fulfilled.

When running frequency controlled fans and using recirculation control you can, depending on the type of fan control, configure a special pressure/flow offset for the setpoint or a manual output signal for the supply air fan.

5.1.12 Change-over

Change-over is a function for installations with 2-pipe systems. It makes it possible to use the same pipe for both heating and cooling, depending on whether heating or cooling is required.

A special analogue output signal, "Y1 Heating/Y3 Cooling", is used for Change-over control. Switching between heating and cooling can be done in two ways. A digital Change-over input signal is normally used. Open contact gives heating control and closed contact gives cooling control. If the input has not been configured, change-over is handled by the internal controller signal. The output signal will follow the two regular output signals "Y1 Heating" and "Y3 Cooling". For heating control, the digital outputs "Heating Activate" and "Heat Step 1-4" are active. For cooling control "Cooling Activate" and "Cool Step 1-3" are active.

If frost protection sensor has been configured, it will function in the usual way when heating is active. However, when cooling is active, it will only be used for indicating temperature.

Three digital output signals, "Heat/Cool Step 1", "Heat/Cool Step 2" and "Heat/Cool Step 3", are also connected with change-over. The signals can be used for reversing a step controlled heating pump etc. See also section 5.1.4 Step controller Heating/ DX cooling.

The change-over function can be split if needed. If so, set the analogue output to “Split” and select the function Y1 Heating/Y3 Cooling.

A digital function called “Split Sequence” is connected to the split signal. It is active when the corresponding analogue signal exceeds 0.1 V.

5.1.13 Extra temperature sensor

The input signals ”Extra Sensor Temp 1”, ”Extra Sensor Temp 2”, ”...”, ”Extra Sensor Temp 5”, can be used to add extra temperature sensors for supervision of temperatures that are not related to any control functions. These sensors will only generate sensor error alarms. “Extra Sensor Temp 1” should be used for external setpoint input.

5.1.14 Extra flow sensors supply air and extract air

The input signals ”Extra SAF Pressure” and ”Extra EAF Pressure” can be used to display the flow in the supply air and extract air ducts. The K- and X-constants for each fan are used to calculate the flow.

5.2 Extra control circuit

An independent temperature control circuit for control of for example after-heaters. The circuit can be configured to heating or cooling. It has an analogue input signal for temperature sensors and an analogue output signal 0...10 V. There is also a digital output signal which is activated when the analogue output signal is above 1 V and deactivated when the analogue signal is below 0.1 V. The circuit can be configured to be active all the time or to be active only when the main unit is running at normal speed.

5.3 Humidity control

General

Humidity control can be configured as Humidification, Dehumidification or both Humidification and Dehumidification.

Two humidity sensors can be connected, a room sensor for control and an optional duct sensor for maximum limiting. The limit sensor can be omitted.

The humidity control is handled by a PI-controller.

The humidity sensors must give 0...10 V DC for 0...100 % RH.

Humidification

An analogue output is used to control a humidifier. The output will increase on decreasing humidity. A digital output can also be used to start a humidifier.

Maximum limitation function using duct humidity sensor:

If the maximum limitation is 80 % RH and the hysteresis is 20 % RH, the controller output signal will begin decreasing at 60 % RH. When halfway to 80 % RH (i.e. when at 70 % RH), half the output signal will be damped. If the humidity in the duct still reaches 80 % RH, the entire output signal will be damped.

Dehumidification

An analogue output is used to control a dehumidifier. The output will increase on increasing humidity. A digital output can also be used to start a dehumidifier.

Humidification/dehumidification

An analogue output is used to control a humidifier. The output will increase on decreasing humidity.

The cooling output Y3 will be activated for dehumidification through condensation. The output will increase on increasing humidity. This signal overrides the cooling signal from the temperature controller so the output can be activated for dehumidification even if the temperature controller demand is zero.

For good temperature control when using cooling for dehumidification it is important that the cooler is placed first in the air stream so that the exchanger and heater can be used to reheat the air after dehumidification.

Digital humidity signal

A digital output signal, "Dehumidification/Humidification", can be used for on/off control of humidifiers/dehumidifiers. The output signal has an activation value and a deactivation value which are connected to the humidity controller output. The signal is activated when the humidity controller output rises above the set activation value and is deactivated when the humidity controller output drops below the set deactivation value.

If a start signal is needed for a cooling unit or a magnetic valve for DX dehumidification, the digital output signal "Start P1-Cooling" should be used. In this case, the "pump" stop delay should be set to 0 s.

Inputs and outputs

AI	Room humidity sensor
AI	Duct humidity sensor
AO	Humidity control output 0...10 V DC
DO	Dehumidification/Humidification

5.4 Fan control

General

Fans can be 1-speed, 2-speed or variable speed via a frequency converter.

1-speed fans are controlled using the digital outputs "Start SAF-Normal" and "Start EAF-Normal".

2-speed fans are controlled using the digital outputs "Start SAF-Normal" and "Start EAF-Normal" as well as "Start SAF-reduced" and "Start EAF-reduced" giving normal and reduced speed respectively.

Variable speed control uses an analogue output per fan for controlling a frequency converter. There are two setpoints for each fan, "Normal" and "Reduced". Pressure or air flow control can be used.

Variable speed fans can also be configured to be run with fixed output values.

Compensation curve

When running pressure control, it is also possible to temperature compensate the pressure.

Crosswise interlock

Crosswise interlock of fans can be configured, which e.g. means that if one fan stops, the other fan will also stop.

Timer outputs, interlock at low outdoor temperatures

The fans are normally controlled by the timer channels for normal and reduced speed. At very low outdoor temperatures, "2-speed fans" or "pressure controlled fans" can be forced to "reduced speed". The limit temperature is settable and the function has a differential of 2K.

Normal, reduced speed

Units with 2-speed or pressure control fans are always started at "reduced speed". After a settable time, Corrigo switches to "Normal speed" if normal speed is valid at start-up. When 2-speed fans are switched from "Reduced speed" to "Normal speed", "Reduced speed" is first disengaged. About 2 sec later, "Normal speed" is activated.

When Corrigo switches from "Normal speed" to "Reduced speed", there is a settable retardation time from disengagement to activation. See the section Retardation time.

The extract air fan and the supply air fan have individual start and stop delays which are normally set so that the extract air fan is started before the supply air fan. If there are not enough digital outputs for individual control, both fans will have to be started using the signal for the supply air fan, and the delay be created using an external time relay.

5.4.1 Pressure control

Frequency control pressure

During pressure control, two separate analogue output signals are used for supply and extract air and two separate analogue input signals for supply and extract air for pressure transmitters. The fan speeds are controlled via frequency converters, thereby maintaining constant pressure. The pressure transmitter inputs are scalable using "Min volt input (Vmin)" and "Max volt input (Vmax)".

A digital activation signal is normally used for each fan ("Start SAF frequency converter" and "Start EAF frequency converter"), for sending a start signal to the frequency converters. The start signal is activated as long as the fan is expected to be running.

For the supply and extract air fans, there are two individually settable setpoint values, one corresponding to normal speed and one corresponding to reduced speed. Changing between the two setpoint values is done using the timer channels for normal and reduced speed or using digital input signals ("Extended Operation, Normal" and "Extended Operation, Reduced").

Outdoor compensation

When running pressure control, it is also possible to outdoor compensate the pressure setpoint value.

The outdoor compensation is linear and is set using two parameter pairs which give the value of the compensation at two different outdoor temperatures. The compensation can be positive or negative.

The outdoor compensation is set in the menu Actual/Setpoint.

Using E tool[®], you can also choose to only outdoor compensate the pressure value of the supply air fan. In that case, the extract air fan is controlled with constant flow, independent of the outdoor temperature.

The compensation can be selected to apply to both normal and reduced speed, or for normal speed only (factory setting = both speeds).

Extra compensation curve

As a complement to the above outdoor compensation, there is a function called "Extra compensation curve" which can be used to set a compensation based on the room, extract air or supply air temperature. The curve has three parameter pairs which correspond to the value of the compensation at three different temperatures.

Controller output-dependent extra compensation curve

The compensation is made using the control curve, one for heating demand and one for cooling demand. It is possible to select whether the compensation (0...100) should increase or decrease the pressure setpoint. The 0...100 compensation follows the current control quantity for the fans, in this case pressure.

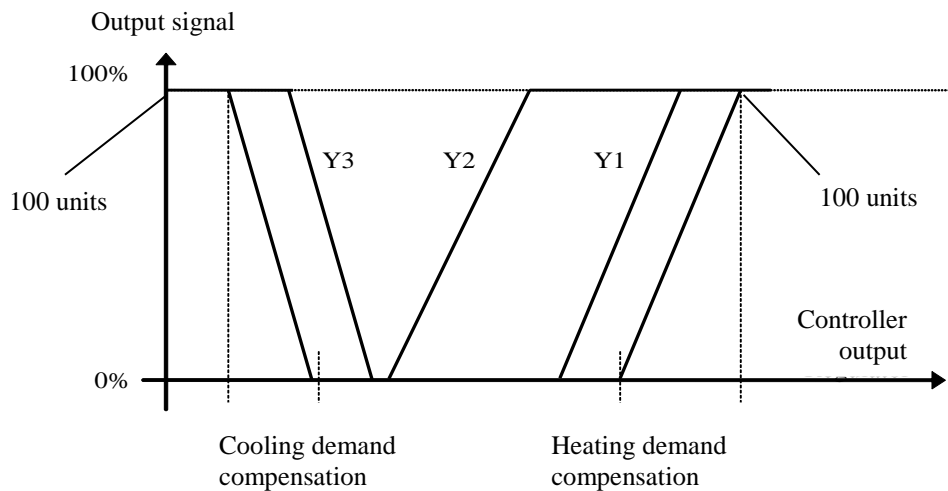

Frequency control flow

Instead of giving a pressure setpoint value, it is possible to use an airflow volume value in m³/h. The value from the pressure transmitter is recalculated to a volume flow using the formula below and the fans will be controlled to give a constant flow.

$$\text{Flow} = K * \Delta P^x$$

Where K and ^x are settable constants dependent on the fan size and ΔP is the differential pressure, measured in Pa, over the fan. Each fan has its own set of parameters.

^x is normally 0.5 indicating that the flow is proportional to the square root of the differential pressure.

Outdoor compensation

Also when running flow control, it is possible to outdoor compensate the setpoint value.

The outdoor compensation is linear and is set using two parameter pairs which give the value of the compensation at two different outdoor temperatures. The compensation can be positive or negative.

The outdoor compensation is set using the menu **Air control>Pressure contr. SAF/EAF>Pressure contr. SAF/EAF>Down arrow**.

Using E tool[®], you can also choose to only outdoor compensate the flow of the supply air fan. In that case, the extract air fan is controlled using constant flow, independent of the outdoor temperature.

The compensation can be selected to apply to both normal and reduced speed, or for normal speed only (factory setting = both speeds).

Extra compensation curve

As a complement to the above outdoor compensation, there is a function called "Extra compensation curve" which can be used to set a compensation based on the room, extract air or supply air temperature. The curve has three parameter pairs which correspond to the value of the compensation at three different temperatures.

Controller output-dependent extra compensation curve

The compensation is made using the control curve, one for heating demand and one for cooling demand. It is possible to select whether the compensation (0...100) should increase or decrease the pressure setpoint. The 0...100 compensation follows the current control quantity for the fans, in this case pressure.

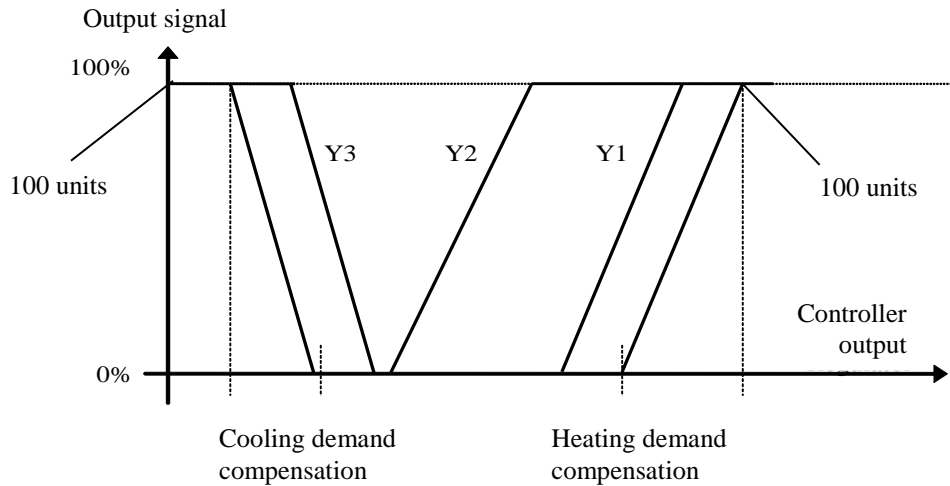

Frequency control manual

Frequency controlled fans can be controlled at a fixed rotational speed. The rotational speed is selected by setting a fixed output signal (0 – 100%). Values for normal and reduced speed can be configured for each fan.

Fans that are run with a fixed output signal can also be compensated (see the section above). In this mode, pressure sensors are not needed.

Frequency control external control signal

Two 0...10 V input signals are used for direct control of frequency controlled fans. The signal is received from e.g. a VAV unit. The signal controls the fans 0...100% (0...10 V on the analogue output). Pressure transmitters are not used in this control mode.

Frequency control SAF with EAF slave

The rotational speed of the supply air fan is controlled by a pressure transmitter which is placed in the supply air duct. The extract air fan does not have a pressure transmitter, instead you let the output for the extract air fan follow the control signal for the supply air fan. A scaling factor can be added if the characteristics of the extract air fan are not the same as the characteristics of the supply air fan. (Only pressure control of the supply air fan is possible using this function.) The extract air fan will start directly at 50% after the start delay. Then the heating of the exchanger will work for this operating mode as well. When the supply air fan starts, the extract air fan will be slave controlled by the supply air flow.

Frequency control EAF with SAF slave

The rotational speed of the extract air fan is controlled by a pressure transmitter which is placed in the extract air duct. The supply air fan has no pressure transmitter. Instead, the supply air fan output is made to follow the extract air fan control signal. A scaling factor can be added if the supply air fan characteristics are not the same as the characteristics of the extract air fan (only pressure control of the extract air fan is possible using this function).

Frequency control SAF with flow control EAF

The rotational speed of the supply air fan is controlled by a pressure transmitter which is placed in the supply air duct. The extract air fan is controlled by the supply air flow, in order to achieve a balanced ventilation. A pressure transmitter which is placed in the supply air fan cone ("Pressure transmitter SAF 2") gives a measured value of the present supply air flow. A corresponding pressure transmitter is placed in the extract air fan cone and gives a measured value of the extract air flow.

The supply air flow is the setpoint used for control of the extract air fan. A scaling factor can be added if the extract air fan does not have the same characteristics as the supply air fan.

Frequency control EAF with flow control SAF

The rotational speed of the extract air fan is controlled by a pressure transmitter which is placed in the extract air duct. The supply air fan is controlled by the extract air duct flow in order to achieve a balanced ventilation. A pressure transmitter placed in the extract air fan cone ("Extra SAF Pressure") provides a measurement of the current extract air flow. A corresponding pressure transmitter is placed in the supply air fan cone, providing a measurement of the supply air flow.

The supply air fan is controlled using the extract air flow as a setpoint. A scaling factor can be added if the supply air fan does not have the same characteristics as the extract air fan.

Frequency control SAF and EAF with external flow setpoint

This signal can be used to control the SAF and EAF flow setpoints from an external VAV system if the "Frequency control external" fan type is used.

If this signal is configured as an analogue input signal, the flow setpoint for the SAF and EAF will be controlled in normal speed.

The signal can be configured by using scaling: Min volt input (Vmin)/Min flow and Max volt input (Vmax)/Max flow.

Minimum limit

For frequency controlled fans an adjustable minimum limit can be set individually on the supply air and extract air fan control signals.

In- and outputs

1-speed	2-speed	Pressure/ Flow	
DO	DO		Start SAF Normal
DO	DO		Start EAF Normal
	DO		Start SAF reduced
	DO		Start EAF reduced
		DO	SAF frequency start
		DO	EAF frequency start
DI	DI		Indication/alarm SAF
DI	DI		Indication/alarm EAF
		AI	Pressure transmitter SAF
		AI	Pressure transmitter EAF
		AI	Pressure transmitter 2 SAF
		AI	Extra pressure transmitter SAF
		AI	Extra EAF Pressure
		AI	External flow setpoint
		AO	Frequency converter SAF
		AO	Frequency converter EAF

5.4.2 Demand controlled ventilation

In applications with varying occupancy the fan speeds or mixing dampers can be controlled by the air quality as measured by a CO₂/VOC-sensor.

You can choose to activate the function "1. Always", "2. Only when the running mode is On", "3. Only when the running mode is Off".

When the function is activated and combined with pressure controlled fans and the CO₂/VOC-value rises above control value one the fans will start at reduced speed, if they are not already running. Should the CO₂/VOC-value continue to rise the fan speed will also increase until the CO₂/VOC-value reaches control value two at which point the fans will be running at normal speed. The fans will stop when the CO₂/VOC-value falls 160 ppm below control value one.

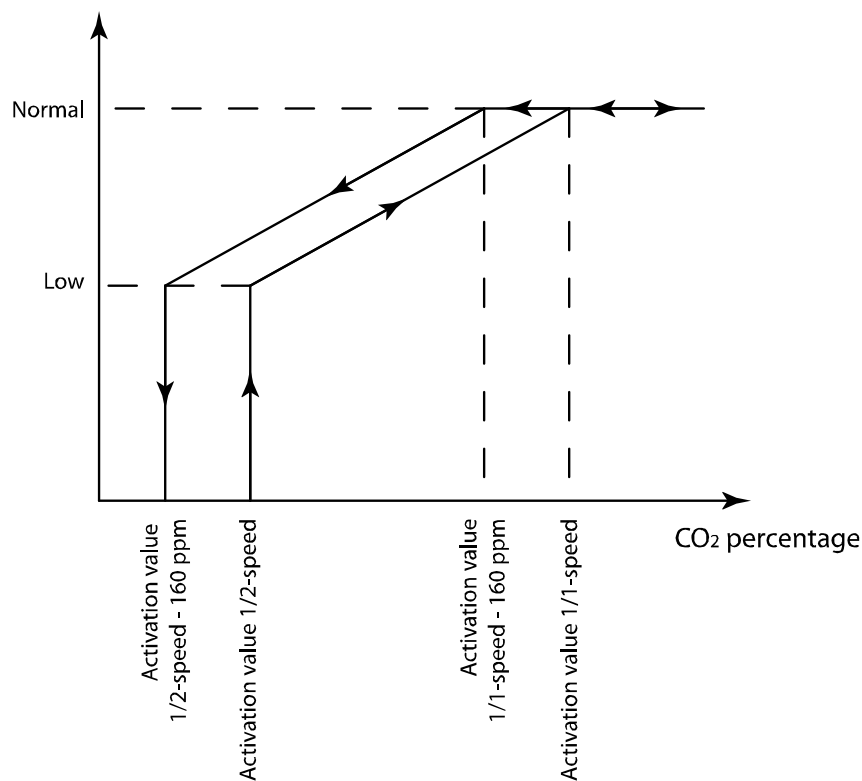

When used with 2-speed fans they will start using reduced speed when the CO₂/VOC-value rises above control value one and switch to normal speed when the CO₂/VOC-value reaches control value two. The fans will stop when the CO₂/VOC-value falls 160 ppm below control value one.

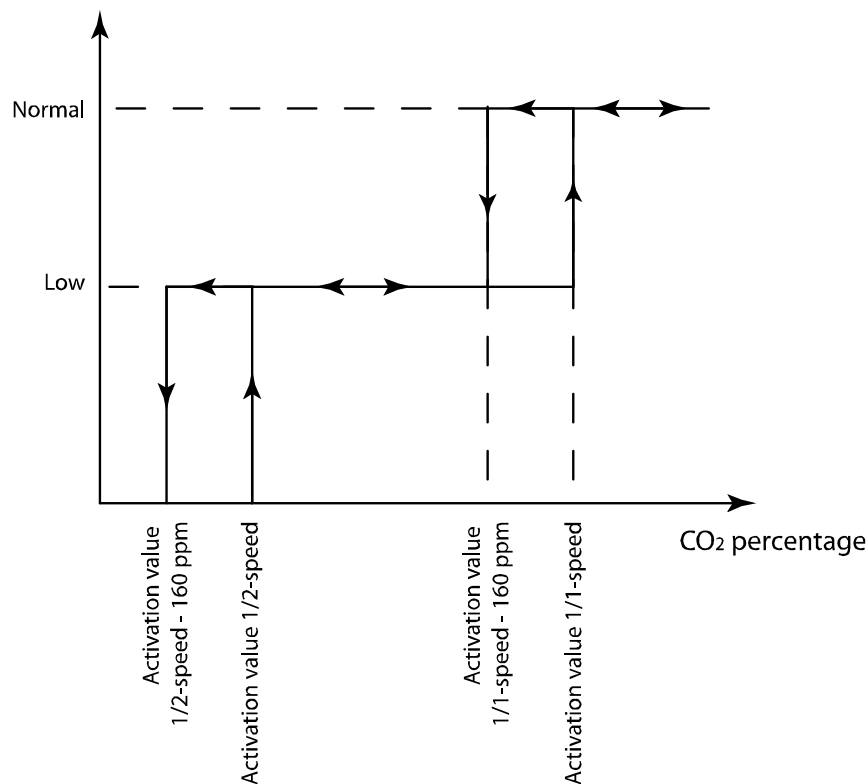

If demand controlled ventilation is activated in combination with mixing dampers, and the CO₂-value rises above the setpoint value, the dampers will let in more outdoor air. The function is controlled by a PI-controller. See section 5.1.3 Heat exchanger types.

The function has a settable minimum running time.

In- and outputs

AI	CO ₂ sensors
-----------	-------------------------

5.5 Pump control

Digital inputs and outputs can be configured for pump control.

All the pumps can use run indication with malfunction alarm *or* an alarm input connected to a motor protection or similar.

5.5.1 Heating circuit

The circulation pump for the heating circuit will always run when the outdoor temperature is lower than a settable value (FS +10°C). At higher outdoor temperatures the pump will run when the heating output is larger than 0V.

If no outdoor temperature sensor has been configured, the stop temperature can be set to 0°C. Then the pump will only run on heat demand.

The pump has a settable stop delay.

The pump will be exercised once daily at 3 p.m. for one minute or the set shortest running time, whichever is the longest.

5.5.2 Exchanger circuit, liquid connected exchangers

The circulation pump for the exchanger circuit will run when the output to the exchanger valve is larger than 0V.

The pump has a settable, shortest running time.

The pump will be exercised once daily at 3 p.m. for 1 minute, or the set stop delay, whichever is the longest.

5.5.3 Cooling circuit

The circulation pump for the cooling circuit will run when the output to the cooling valve is larger than 0V.

The pump has a settable, shortest running time.

The pump will be exercised once daily at 3 p.m. for 1 minute, or the set stop delay, whichever is the longest.

Corrigo E can be configured to block DX cooling if a "Malfunction P1-Cooling" alarm should occur.

In- and outputs

Heating	Exch.	Cooling	
AI			Outdoor temperature sensor
DO	DO	DO	Start/stop circulation pump
DI	DI	DI	Run ind/alarm, circ. pump

5.6 Damper control

5.6.1 Close-off dampers

The outdoor air and exhaust air ducts close-off dampers can be controlled by digital outputs or be hard-wired to the supply air fan relays for normal and reduced speed in such a fashion that the damper is open when the supply air fan is running. When using pressure controlled fans the digital activation signal is activated as soon as the fan has start conditions. This signal can be used to open the close-off damper.

5.6.2 Fire dampers

Fire dampers are normally configured to open on fire alarm. However, via the display you can configure them to be normally open instead.

In Corrigo controllers of generation 1, it was possible to choose whether the extract air fan should be activated on fire alarm or if both fans should be stopped.

For generation 2 controllers, you can use E tool[®] to configure the air handling unit's running mode on fire alarm. The following choices are possible: Stopped, continuous run, run via normal start/stop conditions, only supply air fan in operation, only extract air fan in operation.

For compatibility reasons, the old function has not been removed in generation 2 controllers. This means that old configuration files can be used in new Corrigo controllers as well. If the running mode in the new application has been set to another value than "Stopped", this value will take precedence over the value in the old application.

There is a digital input for detection of open and closed position of the fire dampers.

As of software version 3.2, fire alarm priority has been altered so that the unit will not stop for any other alarm (e.g. frost protection) when it has been configured for continued operation during fire alarms. The digital input "external switch" will still stop the unit.

Fire damper exercising

Fire damper exercising can be configured. The exercise interval is settable. To be able to use this function, all the dampers must have end-position switches.

The digital input: "Fire damper end-switch monitoring" should be wired to all the fire damper end position switches.

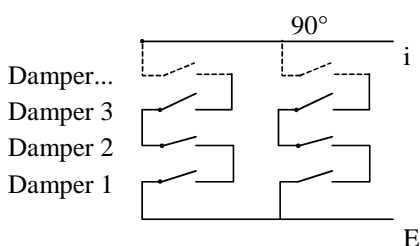

When the test cycle is initiated, the output "Fire dampers" will be activated and the dampers will begin to move. Within the set time (90 sec) the signal on "Fire damper end-switch monitoring" must change to indicate that the dampers have left their normal positions. If not an alarm will be triggered.

Then, within the set time, "Fire damper, end-switch monitoring" must change again to indicate that all the dampers have reached the other end position. If not an alarm will be triggered.

When all dampers have reached the end position the output "Fire dampers" will be reset to drive the dampers back to normal position. Again, within the set time (90 sec) the signal on the input "Fire damper end-switch monitoring" must change to indicate that the dampers have left the end positions. If not an alarm will be triggered.

Then, within the set time, "Fire damper end-switch monitoring" must change again to indicate that all the dampers are back to their normal positions. If not an alarm will be triggered.

The controller can be configured to stop the air handling unit during the damper testing.

All dampers must be wired to the same output in order to get correct results.

The fire alarm input can be configured as normally closed or normally open.

In- and outputs

DO	Outdoor air damper
DO	Exhaust air damper
DO	Fire damper
DI	Fire alarm
DI	Fire damper end switch monitoring

5.7 Extended running and External switch

The digital inputs for extended running can be used to force the unit to start although the timer says the running mode should be "Off". Normal running always takes precedence over reduced speed. "Extended Operation, Normal" takes precedence over the timer output for reduced speed.

For 2-speed fans and pressure/flow controlled fans there are inputs for normal speed and reduced speed. The unit will run for the set time. If the running time is set to 0 the unit will only run as long as the digital input is closed.

The signal "External switch" will stop the unit, even if the timer or one of the signals "Extended Operation, Normal" or "Extended Operation, Reduced" says it should stay in running mode.

In- and outputs

DI	Extended Operation, Normal
DI	Extended Operation, Reduced
DI	External switch

5.8 Time-switch outputs

Up to five digital time-switch outputs can be configured. Each timer channel has a separate scheduler with two periods per week-day.

Timer output five can be used to control the function Recirculation. See 5.1.11.

In- and outputs

DO	Extra time channel 1
DO	Extra time channel 2
DO	Extra time channel 3
DO	Extra time channel 4
DO	Extra time channel 5

5.9 Alarms

Alarm handling

Alarms are indicated by the red alarm LED on the front or on E-DSP.

All alarms can be monitored, acknowledged and blocked using the display and buttons.

Alarm priorities

Alarms can be given different priority levels, A-alarm, B-alarm, C-alarm or not active. Digital outputs can be bound to act as alarm outputs for A-alarms or B/C-alarms or both A- and B/C alarms. The digital outputs can be inverted, so that an inoperative alarm gives a high output and vice versa. A- and B-alarms must be acknowledged to reset. C-alarms automatically reset as soon as there is no longer a cause for alarm.

Stop function

For each alarm there is the possibility of choosing whether activated alarm should stop control or not. Automatic restart will take place after removal of the alarm cause and the alarm has been acknowledged.

For some alarm types such as electric heating high temperature limit and water heating frost protection it would be dangerous to not stop the unit on alarm. Therefore, for such alarm types, the program will always reset the stop function to "Active" even if the operator should choose "Inactive".

Unfortunately it is not possible to remove the display text concerning the stop function for these alarm types. This since the available program space demands that all alarms are treated in the same way in the display.

Note: For alarms that have been set to "Inactive", the extra stop function should also be set to "Inactive", or unexpected malfunctions may occur.

Alarm text

The alarm text that should be shown in the display when there is an alarm can be changed using E tool[®]. For more information, see the E tool[®] manual.

In- and outputs

DO	Sum alarm A + B
DO	Sum alarm A
DO	Sum alarm B/C

Chapter 6 Starting and stopping the unit

6.1 Start conditions

The unit will be started and will run when any one of the following conditions is met:

1. Timer output for normal speed or timer output for reduced speed is ON
2. The unit is started manually using the Corrigo E front panel
3. Digital input for extended running is activated
4. Support control is activated and the present room temperature is higher/lower than the preset starting value (Support heating/cooling)
5. Demand controlled ventilation is activated and the value at the CO₂ sensor is higher than the preset start condition.
6. Recirculation control has been configured and the conditions for recirculation control are fulfilled.

Possibility to block automatic restart at power-up

The function "Automatic restart at power-up" makes it possible to block automatic restart of the unit at power-up. At power-up, the B-alarm "Restart blocked after power on" is generated. Once this alarm has been acknowledged, the unit will start.

6.2 Stop conditions

The unit will be stopped when any of the following conditions are met:

1. Timer output for normal speed or timer output for reduced speed are OFF, and the signal for extended running is OFF.
2. Activated frost protection alarm. The unit will restart on resetting of the alarm.
3. Activated fire detector if the function has been configured. The unit will restart on resetting of the alarm.
4. If the unit has electric heating and the supply fan flow switch alarm or the high temperature limit alarm is activated.
5. Activation of external switch.
6. The unit is stopped manually using the Corrigo E front panel.
7. Support control is activated and the present room temperature is higher/lower than the pre-set stop value (support heating/cooling)
8. Demand controlled ventilation is activated and the value at the CO₂ sensor falls below the pre-set start condition less the set differential.
9. Recirculation control is active and the conditions for recirculation control are no longer fulfilled.
10. At an activated alarm configured with the extra function of stopping the unit on activation. The unit will restart on resetting of the alarm.

6.3 Start sequence

Start of the unit will run according to the following sequence:

1. If the controller is configured for water heating and has an outdoor temperature sensor and the outdoor temperature is below +3°C the heating valve is opened and the heating circulation pump is started.
2. If the controller is configured with a heat exchanger and has an outdoor temperature sensor and the outdoor temperature is below +15°C the heat exchanger will be run at 100% capacity for a pre-set time.
3. Signals for outdoor air and exhaust air dampers are activated.
4. The extract air fan or the pressure control of the extract air fan will be started after a preset time.
5. The supply air fan or the control of the supply air pressure will be started after a preset time.
6. Thereafter temperature control according to the configured control mode is started. Electric heating, if configured, is not started until a run signal from the supply air fan or flow switch has been received. And not yet activated pumps will be started.
7. After a pre-set delay, the alarm handling system is activated. The unit is in normal running mode.

6.4 Stop sequence

Stopping of the unit will run according to the following sequence:

1. Deactivation of the alarm handling system.
2. Electric heating, if configured, is shut down.
3. After individually set delay times the fans are stopped.
4. Outdoor air and exhaust air dampers are shut down.
5. Actuator signals are set to zero and the pumps are stopped.
6. If shutdown mode is configured, it will be activated.

In order to maintain an acceptable supply air temperature as long as possible, the heat exchanger will continue to run during the stop sequence until everything else is stopped.

Chapter 7 Display, LEDs and buttons



This section is applicable to Corrigo E units with display and buttons but also to the hand terminal E-DSP which can be connected to Corrigo E units without display and buttons.

Room units are available with or without display, or as a touch display (see instructions and product sheets for ED-RU..., ED-RU-D... and ED-TCV).

7.1 Display

The display has four rows of 20 characters and is backlit. The illumination is normally off, but is activated as soon as a button is pressed. The illumination will be turned off again after a period of inactivity.

7.2 LEDs

There are two LEDs on the front: The alarm LED marked with the  symbol. The “write enable” LED marked with the  symbol.

The four LEDs placed next to the upper terminal strip will be described later.

7.3 Buttons

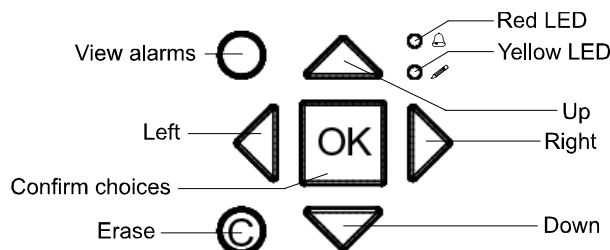

There are seven buttons: four arrow buttons which will be called UP, DOWN, RIGHT and LEFT. The menus in the Corrigo E are organized in a horizontal tree structure. The UP/DOWN buttons are used to move between menus at the present menu level. The RIGHT/LEFT buttons are used to move between menu levels. When changing parameters the UP/DOWN buttons are used to increase/decrease the value of the parameter and the RIGHT/LEFT buttons to move between digits within the parameter.

- The OK button is used to confirm the choice of a parameter setting. See more in the section "Change parameters" below.
- The C button is used to abort an initiated parameter change and restore the original value.
- The ALARM button, marked with a red button top, is used to access the alarm list.

7.4 Navigating the menus

The choice of access level/user access determines which menus are shown in the menu system.

The start display, the display normally shown, is at the root of the menu tree.

```
Regulator vent. sys
2008-11-20 13:30
System: Running
Sp: 18.0 Act: 18.2°C
```

Pressing DOWN will move you through the menu choices at this, the lowest level. UP will move you back through the choices. Which menus are shown depends on which access level you are using (see chapter eight for more information about logging on to higher levels).

Using Normal access, the access which normally does not require logging on, only a few basic menus are shown:

```
Running mode
Temperature
Air control
Humidity control
Time settings
Access rights
```

In the menu "Running mode", you can view and set the unit's running mode, view selected control functions and view the alarm events.

In the menus "Temperature", "Air control" and "Humidity control", you can view actual values and setpoint values. Setpoints can only be changed if you have Operator or Admin access.

In "Time settings", the time, date and set running times are shown. Values can only be changed if you have Operator or Admin access.

Without logging on to Operator or System level, you are only authorised to change the unit's running mode and acknowledge alarms.

With Operator access, you can access more information and change other operation parameters like setpoints and time functions.

With Admin access, you have full access to the complete menu system and can change all parameters.

To enter a higher menu level, use UP or DOWN to place the display marker opposite the menu you wish to access and press RIGHT. At each level there may be several new menus through which you may move using the UP and DOWN buttons.

Sometimes there are further submenus linked to a menu or menu item. This is indicated by an arrow symbol at the right-hand edge of the display. To choose one, use RIGHT again. To back down to a lower menu level, use LEFT.

Change parameters

In some menus there are parameters that can be set. This is indicated by the yellow LED with  flashing.

A quick blinking (2 times/s) indicates that the parameter can be changed using the present user access.

A slower blinking (1 time/s) indicates that a higher user access is required to change the parameter.

To change a parameter, first press the OK button. If you need higher authority than you have to change the parameter, a log on menu will be displayed, see chapter eight below. Otherwise, a cursor will appear at the first settable value. If you wish to change the value, do so by pressing the UP and DOWN buttons.

In numbers containing several digits you can move between the digits using the LEFT / RIGHT-buttons.

When the desired value is displayed press OK.

If there are further settable values displayed the cursor will automatically move to the next one.

To pass a value without changing it, press RIGHT.

To abort a change and return to the initial setting, press and hold the C-button until the cursor disappears.

Chapter 8 Access rights

There are four different access levels. The Admin level has the highest access, while the Service, Operator and basic "no-log on" level have the lowest. The choice of access level determines which menus are shown, as well as which parameters can be changed in the displayed menus.

Admin level gives full read/write access to all settings and parameters in all menus.

Service level gives access to all menus except the submenus "Configuration"/"In- and Outputs" and "Configuration"/"System".

Operator level gives access to all menus except "Configuration".

The basic level only permits changes in "Running mode" and gives read-only access to a limited number of menus.

Repeatedly press the DOWN button when the start-up display is shown until the arrow-marker to the left of the text-list points to "Access rights". Press RIGHT.

```
Log on
Log off
Change password
```

8.1 Log on

```
Log on
Enter password:****
Present level:Normal
```

In this menu it is possible to log on to any access level by entering the appropriate 4-digit code.

The log on menu will also be displayed should you try to gain access to a menu or try to do an operation requiring higher authority than you have.

Press the OK button and a cursor marker will appear at the first digit position. Repeatedly press the UP button until the correct digit is displayed. Press the RIGHT button to move to the next position. Repeat the procedure until all four digits are displayed. Then press OK to confirm. After a short while the text on the line: Present level will change to display the new log on level. Press the LEFT button to leave the menu.

8.2 Log off

Use this menu to log off from the present level to the basic "no-log on" level.

```
Log off?
No
Present level:Admin
```

Automatic logoff

If the access level is Operator, Service or Admin, the user will automatically be logged off to Normal after a settable time of inactivity. See also the section "Automatic logoff". It is possible to remove the automatic logoff, see 8.4 below.

8.3 Change password

As default Corrigo comes with the following passwords for the different levels:

Admin	1111
Service	2222
Operator	3333
Normal	5555

You can only change the password for log on levels lower or equal to the presently active level, i.e. if you are logged in as Admin you can change all passwords, but as Operator you can only change the Operator and Normal passwords. There is no point in changing the Basic password since access to that level is granted automatically to all users.

```
Change password for
level:Operator
New password: ****
```

Note: Do not set the password for Admin to the same value as the password for a lower level since this will prevent access to the Admin level.

Forgotten your password? If the password for Admin has been changed and then lost, a temporary password can be obtained from Regin. This code is date dependent and only valid for one day.

8.4 Change password to remove automatic logoff

If you want to remove the automatic logoff, change the password of the desired level to 0000. After changing the password, the level will always be activated.

Note: This should be done with consideration, since no alarm is continuously given that a certain level has been activated. However, it is very useful in certain cases, if the unit is intended to be used by educated personnel or for instance at commissioning.

Chapter 9 Running mode

Collected here are a number of menus showing running mode, selected functions, alarm events and status of inputs and outputs.

```
Running mode
Selected functions
Alarm events
Input/Output
```

9.1 Running mode, unit

The unit's running mode can be changed without logging on.

```
Running mode
Auto
```

```
Running time
SAF: 14.6 h
Running time
EAF: 14.6 h
```

9.2 Selected functions

Shows the present configuration. These are read-only menus. No changes can be made here.

```
Control function
Supply air control
Fan control
1-speed.
```

```
Heating: Water
Exchanger: Plate exc
Cooling: Water
```

```
Free cool active: No
```

```
Support control
Active: Yes
CO2/VOC active
If time channel on
```

```
Fire damper function
Not active
Operation when alarm
Stopped
```

```
Frost protection
Active
Cooling recovery
No
```

```
External setpoint
Not active
```

9.3 Alarm events

Alarm log which contains the 40 latest alarm events. The most recent event is listed first. The alarm log can only be used for viewing the alarm history. Alarms are handled in a special area, see section 18.1.

```
24 Nov 14:32 B
Malf. SAF

Acknowledged
```

9.4 Inputs/Outputs

This is a read-only menu block showing the present values for all configured inputs and outputs. If correction factors have been applied to input values, the corrected values will be shown.

This is a read-only menu. No changes can be made here.

```
AI
DI
UI
AO
DO
```

Analogue inputs and digital outputs are shown here as examples.

Analogue inputs

```
AI1: 18.5 Outdoortemp
AI2: 20.3 Supplytemp
AI3: 28.2 Extracttemp
AI4: 19.9 Roomtemp1
```

Digital outputs

```
DO1:Off SAF 1/1-speed
DO2:Off EAF 1/1-speed
DO3: On P1-Heating
DO4:Off Sum alarm
```

Chapter 10 Temperature

Here you can view all actual and setpoint values for temperature control. The menu is visible to all users, regardless of log on level. However, to make changes you need at least Operator authority.

The below menus are available, providing the corresponding input has been activated.

Setpoints are available with a separate value for reduced speed. This is achieved using a temperature offset when the unit runs in reduced speed.

The temperature is available in either Celsius (°C) or Fahrenheit (°F).

Setpoint.

Control mode 1: Supply air control.

```
Outdoor temp.: 18.4°C
Supply air temp
Act.: 19.8°C Setp →
Setp.: 20.0°C
```

Submenu: Setpoint

```
Supply air temp
Setp.: 20.0°C
```

Setpoint.

Control mode 2: Outdoor compensated supply air control.

Control mode 5: Outdoor temperature dependent supply air or room temperature control.

Control mode 6: Outdoor temperature dependent supply air or extract air control.

```
Outdoor temp.: 18.4°C
Supply air temp
Act.: 19.8°C Setp →
Setp.: 20.0°C
```

Submenu: "Setpoint curve"

In control modes five and six, the setpoint relationship is used when supply air control is active.

Use the eight breakpoints to generate a "setpoint"/"outdoor temperature" relationship.

Both the outdoor and supply air temperatures are changeable for the curve.

```
Outdoor comp. setp.
-20.0°C = 25.0°C
-15.0°C = 24.0°C
-10.0°C = 23.0°C
```

```
Outdoor comp. setp.
-5.0°C = 23.0°C
0.0°C = 22.0°C
5.0°C = 20.0°C
```

```
Outdoor comp. setp.  
10.0°C = 18.0°C  
15.0°C = 18.0°C
```

In-between-values are calculated using straight lines between breakpoints. Setpoints for temperatures lower than the lowest breakpoint and higher than the highest breakpoint are calculated by extending the line between the two last breakpoints at either end.

Example: At the lower end the setpoint is increasing by 1°C for every 5 °C lowering of the outdoor temperature. So the setpoint at -23°C would be 25°C + .6x 1.0°C = 25.6°C.

Setpoint. Control mode 3 and 5: Cascaded room temperature control.

```
Room temp.1  
Actual: 22.0°C  
Setpoint: 21.5°C →
```

In control mode five, the setpoint is used when cascade connected room control is active.

Submenu for setting the min and max limitation temperatures for the supply air.

```
If cascade control  
max/min supply setp.  
Max: 30.0°C  
Min: 12.0°C
```

If two room sensors have been configured you will also get the following menu:

```
Room temp.2  
Actual: 21.8°C
```

Setpoint.

Control mode 4: Cascade connected extract air control.

Control mode 6: Outdoor temperature-dependent supply or extract air control.

```
Extract air temp.  
Actual: 21.0°C  
Setpoint: 21.1°C
```

In control mode six, the setpoint is used when cascade connected extract air control is active.

Submenu for setting the min. and max. limitation temperatures for the supply air.

```
If cascade control  
max/min supply setp.  
Max: 30.0°C  
Min: 12.0°C
```

Setpoint

Control mode 8: Outdoor temperature compensated extract air control.

```
Extract air temp  
Actual: 21.0°C  
Setp.: 21.1°C
```

```
Outdoor comp. setp.  
-20.0°C = 25.0°C  
-15.0°C = 24.0°C  
-10.0°C = 23.0°C
```

```
Outdoor comp. setp.  
-5.0°C = 23.0°C  
0.0°C = 22.0°C  
5.0°C = 20.0°C
```

```
Outdoor comp. setp.  
10.0°C = 18.0°C  
15.0°C = 18.0°C
```

```
If cascade control  
max/min supply setp.  
Max: 30.0°C  
Min: 12.0°C
```

In control mode 8, the extract air setpoint is compensated based on outdoor temperature. Note that the curve must be adjusted for optimal functionality.

Both the outdoor and extract air temperature are changeable for the curve.

Support control heating

```
Support heating  
Room temp for  
Start: 15.0°C  
Stop: 21.0°C
```

Support control cooling

```
Support cooling  
Room temp for  
Start: 30.0°C  
Stop: 28.0°C
```

Frost protection temperature

```
Frost protection  
Actual: 30.9°C
```

De-icing exchanger

```
De-icing exchanger  
Actual: 11.2°C  
Setpoint: -3.0°C  
Hysteresis: 1.0°C
```

Heat exchanger efficiency monitoring

```
Efficiency exch.  
Actual: 93%  
Output exchanger  
Actual: 100%
```

Recirculation (see 5.1.11)

```
Temp.setpoint when  
recirc. (Supply/  
Extract/Room)  
18.0°C
```

```
Offset SAF when  
frequency control  
and recirculation:  
0.0 Pa
```

"Offset SAF" makes it possible to add an offset to the setpoint during normal operation. If pressure control has been configured, the offset is set in Pa. If flow control has been configured, it is set in m³/h. If manual control has been configured, the offset is set in percent.

Extra control circuit (see 5.2)

```
Extra control circuit  
Actual: 21.2°C  
Setpoint: 20.0°C
```

Enthalpy control

```
Enthalpy indoor:  
33.8 KJ/Kg  
Enthalpy outdoor:  
35.0 KJ/Kg
```

Submenus

```
Outdoortemp  
Act.: 12.8 °C  
Humidity Outdoor  
Act.: 98.7% RH
```

```
Indoortemp  
Act.: 17.2 °C  
Humidity indoor  
Act.: 55.7 % RH
```

Status enthalpy control

```
Override cool Recovery  
due to Enthalpy:  
Active
```

Chapter 11 Air control

Pressure control SAF and EAF

When using pressure or flow controlled fans, the setpoint can be temperature compensated.

The compensation has the default value 0 Pa, i.e. no compensation is added. The compensation is linear between the setting points. The compensation can be positive or negative.

The same compensation normally applies to both fans. Using E tool[®], you can choose to compensate only the supply air fan.

The same compensation is applied to both "Normal" and "Reduced", which means that you need to take caution when using this function so the pressure does not become too low or even negative when running reduced speed.

Depending on the choice of fan control, different combinations of the menus below will be shown.

Pressure control SAF (there are corresponding menus for EAF).

```
Pressure contr. SAF
Actual: 480 Pa
Setp.: 490 Pa   →
```

Submenu "Setpoint"

```
Pressure contr. SAF
Setp 1/1: 490 Pa
Setp 1/2: 300 Pa
```

Submenu "Outdoor compensation"

```
Outd. comp. setp.
-20 °C = -50 Pa
 10 °C =  0 Pa
Act. Comp: -5 Pa
```

Submenu "Extra compensation curve"

```
Comp.sens.:Roomtempl
15 °C = 0 Pa
20 °C = 0 Pa
25 °C = 0 Pa
```

Submenu "Controller output compensation if cooling"

```
Controller output
comp if cooling
0 at HCOUT= 0%
100 at HCOUT= 0%
```

Submenu "Controller output compensation if heating"

```
Controller output
comp if heating
0 at HCOUT= 0%
100 at HCOUT= 0%
```

The compensation follows the current control quantity, in this case pressure.

Submenu "Controller output compensation"

```
Controller output
compensation
Not active
```

Submenu "Compensation only when"

```
Compensation only
when:
1/1-speed: No
defrosting: No
```

Flow units can be measured in both m³/h (cubic meters per hour) and in CFM (cubic feet per minute).

Flow control SAF (there are corresponding menus for EAF).

```
Flow control SAF
Actual: 1800 m3/h
Setp.: 2000 m3/h →
```

Submenu "Setpoint"

```
Flow control SAF
Setp 1/1: 2000 m3/h
Setp 1/2: 1000 m3/h
```

Submenu "Outdoor compensation"

```
Outdoor comp. setp.
-20 °C = 0.0 m3/h
10 °C = 0.0 m3/h
Act. Comp: 0.0 m3/h
```

Submenu "Extra compensation curve"

```
Comp.sens.:Roomtempl
15 °C = 0 m3/h
20 °C = 0 m3/h
25 °C = 0 m3/h
```

Submenu "Controller output compensation if cooling"

```
Controller output
comp if cooling
0 at HCOUT= 0%
100 at HCOUT= 0%
```

Submenu "Controller output compensation if heating"

```
Controller output
comp if heating
0 at HCOUT= 0%
100 at HCOUT= 0%
```

The compensation follows the current control quantity, in this case pressure.

Submenu "Controller output compensation"

```
Controller output
compensation
Not active
```

Submenu "Compensation only when"

```
Compensation only
when:
1/1-speed: No
defrosting: No
```

Flow units can be measured in both m³/h (cubic meters per hour) and in CFM (cubic feet per minute).

Manual frequency control SAF (there are corresponding menus for EAF).

```
Frequency control
manual SAF
Output: 75% →
```

Submenu "Setpoint"

```
Frequency control
manual SAF
Output 1/1: 75%
Output 1/2: 50%
```

Submenu "Outdoor compensation"

```
Outdoor comp. outp.
-20 °C = 0 %
10 °C = 0 %
Act. Comp: 0 %
```

Submenu "Extra compensation curve"

```
Comp.sens.:Roomtemp1
15 °C = 0 %
20 °C = 0 %
25 °C = 0 %
```

Submenu "Controller output compensation if cooling"

```
Controller output
comp if cooling
0 at HCOU= 0%
100 at HCOU= 0%
```

Submenu "Controller output compensation if heating"

```
Controller output
comp if heating
0 at HCOU= 0%
100 at HCOU= 0%
```

The compensation follows the current control quantity, in this case %. The function should not be used when fan setpoint is set to %, as the fans will then risk stopping in some modes.

Submenu "Controller output compensation"

```
Controller output
compensation
Not active
```

Submenu "Compensation only when"

```
Compensation only
when:
1/1-speed: No
defrosting: No
```

Flow units can be measured in both m³/h (cubic meters per hour) and in CFM (cubic feet per minute).

CO₂ / VCO

```
CO2
Actual:920ppm
Setp:850pm
```

Chapter 12 Humidity control

Humidity control can be configured as Humidification, Dehumidification or both Humidification and Dehumidification.

Two humidity sensors can be connected, a room sensor for control and an optional duct sensor for maximum limiting. The limit sensor can be omitted.

The humidity control is handled by a PI-controller.

The humidity sensors must give 0...10 V DC for 0...100 % RH.

Humidity sensor room

```
Humidity room
Actual: 51.9% RH
Setp: 50.0% RH
```

Humidity sensor duct

```
Humidity duct
Actual: 72.2% RH
Max limit: 80.0% RH
Hyst.: 20.0% RH
```

If the maximum limitation is 80 % RH and the hysteresis is 20 % RH, the controller output signal will begin decreasing at 60 % RH. When halfway to 80 % RH (i.e. when at 70 % RH), half the output signal will be damped. If the humidity in the duct still reaches 80 % RH, the entire output signal will be damped.

Chapter 13 Time settings

General

Corrigo has a year-base clock function. This means that a week-schedule with holiday periods for a full year can be set. The clock has an automatic summertime/wintertime change-over.

Individual schedules for each week-day plus a separate holiday setting. Up to 24 individual holiday periods can be configured. A holiday period can be anything from one day up to 365 days. Holiday schedules take precedence over other schedules.

Each day has up to two individual running periods. For two-speed fans and pressure controlled fans there are daily individual schedules for normal speed and reduced speed, each with up to two running periods.

Up to 5 digital outputs can be used as timer controlled outputs. Each with individual week-schedules with two activation periods per day. These outputs can be used to control lighting, doorlocks etc.

```
Time/Date
Timer Normal speed
Timer Reduced speed
Extended running
Timer output 1    →
Timer output 2    →
Timer output 3    →
Timer output 4    →
Timer output 5    →
Holidays          →
```

13.1 Time / Date

This menu shows and permits the setting of time and date.

Time is shown in 24-hour format.

Date is shown in the format YY:MM:DD.

```
Time: 18:21
Date: 04-08-04
Weekday: Wednesday
```

13.2 Timer Normal speed

There are eight separate setting menus, one for each weekday and one extra for holidays. Holiday schedules take precedence over other schedules.

For 24 hour running, set a period to 0:00 – 24:00.

To inactivate a period, set the time to 00:00 – 00:00. If both periods of a day are set to 0:00 – 0:00, the unit will not run at 1/1-speed that day.

```
Normal speed
Monday
Per 1: 07:00 - 16:00
Per.2: 00:00 - 00:00
```

If you want to run the unit from one day to another, e.g. from Mon 22:00 to Tue 09:00, the desired running time for both days must be entered.

```
Normal speed
Monday
Per 1: 07:00 - 16:00
Per.2: 22:00 - 24:00
```

```
Normal speed
Tuesday
Per 1: 00:00 - 09:00
Per.2: 00:00 - 00:00
```

13.3 Timer Reduced speed

These settings will be ignored if single speed fans are configured.

Should periods for normal speed and periods for reduced speed overlap, normal speed takes precedence.

There are eight separate setting menus, one for each weekday and one extra for holidays. Holiday schedules take precedence over other schedules. For 24 hour running, set a period to 00:00 – 24:00. To disable a period, set it to 00:00 – 00:00. If both periods of a day are set to 00:00 – 00:00, the unit will not run at "Reduced speed" that day.

```
Reduced speed
Sunday
Per 1: 10:00 - 16:00
Per.2: 00:00 - 00:00
```

13.4 Extended running

Digital inputs can be used to force the unit to start although the timer says the running mode should be "Off".

For 2-speed fans and pressure/flow controlled fans, inputs for normal speed and reduced speed can normally be used.

The unit will run for the set time. If the running time is set to zero the unit will only run as long as the digital input is closed.

```
Extended running
60 min
Time in ext. Running
0 min
```

13.5 Timer outputs 1...5

Up to 5 digital outputs can be used as timer controlled outputs. Each with individual week-schedules with two activation periods per day. Each output has eight separate setting menus, one for each weekday and one extra for holidays. Holiday schedules take precedence over other schedules.

Only the time channels which have been configured, i.e. have been wired to a digital output, will be shown.

```
Timer output 2
Wednesday
Per.1: 05:30 - 08:00
Per.2: 17:00 - 23:00
```

If the function "Recirculation" has been configured (see 5.1.11), "Timer output 5" can be used to control start/stop of the recirculation function.

13.6 Holidays

Up to 24 separate holiday periods for a full year can be set.

A holiday period can be any number of consecutive days from 1...365. The dates are in the format: MM:DD.

When the present date falls within a holiday period, the scheduler will use the settings for the weekday "Holiday".

Holidays (mm:dd)
1: 01-01 - 02-01
2: 09-04 - 12-04
3: 01-05 - 01-05

Chapter 14 Manual / Auto

General

In this menu the running mode of all the configured output signals and a number of control functions can be manually controlled. This is a very handy feature which simplifies the checking of individual functions in the Corrigo.

The running mode for the whole unit is set in the menu "Running mode". See section 9.1.

The supply air controller's output signal can be manually set (Manual/Auto) to any value between 0 and 100 %. The temperature output signals will change accordingly if they are in "Auto" mode. It is also possible to manually control each of the temperature output signals individually.

All the configured digital outputs can be set to "Auto", "Off" or "On".

Since leaving any of the outputs in manual control will disrupt the normal control, an alarm will be generated as soon as any output is set to a manual mode.

Since the menus vary according to the configuration of the outputs only the most common ones will be shown here. For the digital signals you can normally choose between "Auto" and "On" and "Off" or similar words indicating the two possible manual states of the digital output.

Manual/Auto

Supply air controller running mode

Can be set to "Auto", "On" or "Off". In manual "On" mode the output signal can be set 0...100 %. The outputs "Y1", "Y2" and "Y3", if in "Auto" mode, will follow the signal according to the set split values.

```
Supply temp contr.  
Auto  
Manual set: 42.0
```

Start signal "SAF" and "EAF"

Can be set to manual 1/1-speed, manual 1/2-speed and off. Manual 1/2-speed is not valid for single speed fans.

```
SAF  
Auto
```

```
EAF  
Auto
```

With pressure controlled fans you get the following menu: Can be set to "Auto", "Manual normal", "Manual reduced", "Manual" and "Off". In "Manual" mode the output signal can be set 0...10 V.

```
Pressure SAF: Auto  
Manual set: 0.0
```

EAF: Auto
Manual set: 0.0

Y1 heating output

Heating
Auto
Manual set: 0.0

Y2 heat exchanger

Exchanger
Auto
Manual set: 0.0

Y3 cooling

Cooling
Auto
Manual set: 0.0

Humidification/dehumidification

Humidification/Dehumidification
Auto
Manual set: 0%

Circulation pumps: Heating, Exchanger and Cooling

P1-Heating
Auto
P1-Exchanger
Auto

P1-Cooling
Auto

Dampers: Outdoor air, Recirculation air, Exhaust air and Fire dampers

Outdoor air damper
Auto

Exhaust air damper
Auto

Extra control circuit

Extra ctrl. unit
Auto
Manual set: 0.0

Extra sequence Y4

Extra sequence Y4
Auto
Manual set: 0.0

Extra sequence Y5

Extra sequence Y5
Auto
Manual set: 0.0

Chapter 15 Settings

In this menu group all settings for all activated functions should be available. The menu group is only available when logging on as Admin. Depending on what choices have been made during configuration, some of the alternatives in this menu group may not be shown.

Settings

```
Control temp
Control pressure
Control flow
Control humidity
Control CO2
Control extra unit
Alarm settings
```

15.1 Control temp

Supply air controller

```
Supply air control
P-band: 33.0 °C
I-time: 100.0 sec
```

The set P-band for the supply air controller is for the whole controller signal. This means that the P-band for each sequence is proportionate to the split percentage values given to sequences.

For example:

P-band for the supply air controller is set to 25 K. The split is set so that cooling gets 0...20 % = 20 %, the exchanger gets 30...50 % = 20 % and the heater gets 50...100 % = 50 %.

The individual P-bands will then be:

Chiller: 20 % of 25°C = 5°C

Exchanger: 20 % of 25°C = 5°C

Heating: 50 % of 25°C = 12.5°C

The remaining 2.5°C are the neutral zone between cooling and exchanger.

The split values are set in the configuration submenu *Other parameters*. See section 16.24.6.

```
If cascade control
max/min supply setp.
Max: 30°C
Min: 12°C
```

Room controller

```
Room control
P-band: 100.0 °C
I-time: 300.0 sec
```

Extract air controller

```
Extract air control
P-band: 100.0 °C
I-time: 300.0 sec
```

Shutdown mode

```
Shutdown mode
P-band: 100.0 °C
I-time: 100 sec
```

Frost protection temperature

```
Frost protection
temperature →
```

```
Frost protection
Active
Setp shutdown: 25°C
P-band active: 5°C
```

```
Fast stop at
frost-protection alarm
Yes
```

"Setp shutdown" is the shutdown mode setpoint.

P-band active 5°C means that the frost protection controller will start overriding the heating output when the frost protection temperature is less than five degrees above the set frost alarm limit. The default alarm limit is 7°C. It can be changed in the menu Settings/Alarm settings/Alarm limits/Alarm limit frost protection.

Exchanger de-icing

```
De-iceing
P-band: 100 °C
I-time: 100 sec
```

15.2 Control pressure

Pressure control SAF

```
Pressure control SAF
P-band: 500 Pa
I-time: 60 sec
Min Output: 0 %
```

Pressure control EAF

```
Pressure control EAF
P-band: 500 Pa
I-time: 60 sec
Min Output: 0 %
```

15.3 Control flow

Flow control SAF

```
Flow control SAF
P-band: 1000 m3/h
I-time: 60 sec
Min Output: 0 %
```

Flow control EAF

```
Flow control EAF
P-band: 1000 m3/h
I-time: 60 sec
Min Output: 0 %
```

15.4 Humidity control

```
Control humidity
P-band: 100.0 %RH
I-time: 300.0 sec
```

15.5 Control Extra unit

```
Control extra
unit
P-band: 33.0 °C
I-time: 100.0 sec
```

15.6 Alarm settings

Alarm settings

```
Alarm limits →
Alarm delays →
Restore alarm →
```

15.6.1 Alarm limits

Alarm limits, supply air

```
Al. lim. supply air
Control dev: 10.0 °C
High temp: 30.0 °C
Low temp: 10.0
```

Alarm limits, extract air

```
Al. lim. extract air
High temp: 30.0 °C
Low temp: 10.0 °C
```

Alarm limits, room

```
Al. lim. room air
High temp: 30.0 °C
Low temp: 10.0 °C
```

Alarm limit frost protection

```
Alarm limit frost
protection
7.0 °C
```

Alarm limit, pressure

```
Control dev SAF
40.0 Pa
Control dev EAF
40.0 Pa
```

Alarm limit Humidity

```
Control deviation
humidity
10 %
```

Alarm limit, exchanger efficiency

```
Low efficiency
50.0 %
```

Service alarm filter

```
Service alarm
(Filter alarm)
Time until alarm
Activates: 0 month
```

15.6.2 Alarm delays

Alarm delay, supply air

```
Al. del. supply air
Control dev: 30 min
High temp: 5 sec
Low temp: 5 sec
```

Alarm delay, extract air

```
Al. del. extract air
High temp: 30.0 min
Low temp: 30.0 min
```

Alarm delay, room

```
Al. del. room air
High temp: 30.0 min
Low temp: 30.0 min
```

Alarm delay, frost protection

```
Alarm delay
Frost prot.: 0 sec
Frost risk: 0 sec
```

Alarm delay control SAF and EAF

```
Alarm delay control
dev. pressure
SAF: 30 min
EAF: 30 min
```

Alarm delay, Humidity

```
Alarm delay control
deviation humidity 30
Min
```

Alarm delay, exchanger efficiency

```
Low efficiency
30 min
```

Alarm delay, fan malfunction

```
Alarm delay malfunc.
SAF: 120 sec
EAF: 120 sec
```

Alarm delay, pump malfunction

```
Alarm delay malfunc.
P1-Heating: 5 sec
P1-Cooling: 5 sec
P1-Exchan.: 20 sec
```

Alarm delay, misc.

```
Alarm delay
Filter mon.: 180 sec
Flow switch: 5 sec
Frost prot.: 0 sec
```

Ext. Frost prot. DI refers to the digital input signal Deicing Heat exchanger.

Alarm delay, misc. 2

```
Alarm delay
Deicing DI: 0 sec
Fire alarm: 0 sec
Ext. alarm: 0 sec
```

Frost protection DI refers to the digital input signal De-icing thermostat exchanger.

Alarm delay, misc. 3

```
Alarm delay
Elec. heat: 0 sec
Sensor error: 5 sec
Rot.sent.exch: 20 sec
```

15.6.3 Restore alarm

```
Service alarm
(filter alarm)
Time counter set to
zero: No
```

15.7 Save and restore settings

```
Restore factory
settings: No
Restore user settings:
No
```

In this menu, it is possible to restore all parameters to their factory settings or to the user settings they were saved as earlier, see below.

```
Save user settings: No
```

The present configuration can be saved in a separate memory area and can later be restored using the previous menu, "Restore user settings".

Chapter 16 Configuration

Start by logging on as Admin. See chapter 8.

Move the marker using the DOWN and UP buttons until it is opposite the menu "Configuration" and press RIGHT.

The configuration main menu is shown (different menus are visible depending on the configured inputs and outputs).

```
Inputs/Outputs
Control function
Fan control
Extra control unit
Extra sequence Y4
Extra sequence Y5
Heating
Exchanger
Cooling
Pump control
Free cooling
Support control
CO2/VOC control
Fire function
Humidity control
Exchanger de-icing
Cooling recovery
Enthalpy control
Min lim. dampers
External setpoint
Run ind/Motor prot.
Actuator type
Actuator run time
Actuat. period time
Step controllers
Recirculation
Pretreatment
Alarm settings
Communication
Other parameters
System
```

16.1 Inputs and outputs

```
AI
DI
UI
AO
DO
```

General

Free configuration

Any control signal can be bound to any in- and output, the only restriction being that digital signals cannot be bound to analogue inputs and vice versa. It is up to the user doing the binding to make sure that activated functions are bound to appropriate in- and outputs.

Delivery setting

On delivery all the physical in- and outputs have already been bound to a signal.

The delivery settings are suggestions only and can easily be changed.

16.1.1 Analogue inputs AI

```
AI1
Sign: Outdoor temp
Raw value: 18.4
Compensation:0.0
```

All analogue inputs are for PT1000 or 0...10 V.

Input signals can be compensated e.g. for wiring resistance.

The raw value will show the actual, uncompensated input value.

If inputs have been assigned to pressure or flow control of fans, alternatively humidity or CO₂ control, the following menus will appear:

```
SAF Pressure at
0V: 0.0 Pa
10V:500.0 Pa
Filter factor: 0.2
```

```
CO2 at
0V: 0.0 ppm
10V: 2000 ppm
Filter factor: 0.2
```

Set the parameter values that should correspond to the input signal levels 0 V and 10 V.

The filter factor is the damping you want the program to work with in order to reduce the influence of potential signal fluctuations on the sensor input. The filter factor can be changed via the display or E tool[®] and is found after "analogue inputs" in "configuration". A new value is calculated using the following formula:

```
New value = old value * filter factor + raw value * (1 - filter factor)
```

16.1.2 Digital inputs DI

```
DI1
NO/NC: NO Signal:
Filter alarm 1
Status: No
```

To simplify adaptation to external functions, all digital inputs can be configured to be either normally open, NO, or normally closed, NC.

The inputs are as standard normally open, i. e. if the input is closed, the function connected to the input in Corrigo is activated.

Be careful when changing the input from NO to NC since some digital functions can be configured to either NO or NC themselves. For example, you can choose if the Fire alarm input should be activated when it is closed or opened. Therefore, there is a risk that the signal is changed twice and the result is the opposite of the desired.

16.1.3 Universal inputs UI

On the largest hardware version, E28 there are universal inputs. These can individually be configured as either analogue inputs or as digital inputs. When configured as analogue inputs they can be bound to any of the analogue signals described under Analogue signals.

When configured as digital inputs they can be bound to any of the digital signals described under "Digital signals".

```
UI1 →
Choose AI or DI sign
AI sign: SAF pressure
DI sign: Not used
```

After choosing AI or DI signal (the unused alternative must be set to *not active*) there are submenus with settings. These menus are accessed by pressing RIGHT.

```
UA11
Sign: SAF pressure
Raw Value:8.5
Compensation: 0.0
```

```
UD11
NO/NC: NO Signal
Not used
Status: No
```

To simplify adaptation to external functions, all universal inputs configured as digital inputs can be set to be either normally open, NO, or normally closed, NC.

The inputs are as standard normally open, i. e. if the input is closed, the function connected to the input in Corrigo is activated.

Be careful when changing the input from NO to NC since some digital functions can be configured to either NO or NC themselves. For example, you can choose if the Fire alarm input should be activated when it is closed or opened. Therefore, there is a risk that the signal is changed twice and the result is the opposite of the desired.

16.1.4 Analogue outputs

Analogue outputs are 0...10 V DC.

```
AO1
Sign: Y1-Heating
Auto
Value: 0.0 V
```

Analogue outputs can be set in run mode "Auto", "Manual" or "Off".

16.1.5 Digital outputs

```
DO1
Signal: SAF 1/1-speed
Auto
Status: On
```

Digital outputs can be set in run mode "Auto", "Manual-On" or "Manual-Off".

16.2 Control function

```
Control function
Mode:
Supply air control
```

There are six different control functions to choose from:

1. Supply air control.
2. Outdoor-temperature compensated supply air control.
3. Cascaded room temperature control
4. Cascade connected extract air temperature control.
5. Outdoor temperature dependent switching between outdoor compensated supply air temperature control and room temperature control
6. Outdoor-temperature controlled switching between Outdoor-temperature compensated supply air control and Cascade connected extract air temperature control.

For detailed description of the control modes, see section 5.1.1 Control modes.

In control modes five and six, there is a submenu for setting of the change-over outdoor temperature.

```
Outdoor temp for
control mode change
13°C
```

16.3 Fan control

```
Fan control
1-speed
```

Choose between "Single-speed", "Two-speed", "Pressure control", "Flow control", "Frequency manual" (fixed output), "Frequency external control", "SAF with EAF slave", or "SAF with EAF flow control".

For detailed description of fan control alternatives, see section 5.4 Fan control.

Flow control

If flow control has been configured, there is a submenu for setting of calculation parameters for conversion of pressure to flow. There are two menus, one for "SAF" and one for "EAF".

```
SAF flow control
factors
K-constant: 100
X-constant: 0.50
```

For more detailed description, see the section Air flow control under 5.4.1 Pressure control.

SAF with EAF slave / EAF with SAF slave

If fan slave operation has been configured, there is a submenu for setting the CAV factor, a factor which determines the slave fan output in relation to the output of the controlling fan.

```
SAF/EAF CAV factor:
1.00
```

For more detailed description, see the section SAF with EAF slave under 5.4.1 Pressure control.

SAF with EAF flow control / EAF with SAF flow control

If fan slave operation and flow control has been configured, there are submenus for setting the flow calculation factors for "SAF" and "EAF", and the CAV factor for "SAF/EAF".

```
SAF flow control
factors
K-constant: 100
X-constant: 0.50
```

```
EAF flow control
factors
K-constant: 100
X-constant: 0.50
```

```
SAF/EAF CAV factor:  
1.00
```

For more detailed description, see the section SAF with EAF flow control / EAF with SAF flow control under 5.4.1 Pressure control.

Crosswise interlock between fans

Crosswise interlock means that if one of the fans stops running, the other fan will automatically stop as well.

```
Crosswise interlock  
between SAF and EAF  
No
```

16.4 Extra control circuit

The extra control circuit can be configured to be either constantly active or to be active only when the regular control circuit is active.

```
Mode extra unit  
Running if  
unit runs
```

The extra control circuit can be configured to be either a heating or a cooling circuit.

```
Control mode extra  
unit:  
Heating
```

16.5 Extra sequence Y4

"Extra sequence Y4" can be configured to one of the following alternatives: "Active", "Active with cooling recovery", "Active with enthalpy control" and "Active with both cooling recovery and enthalpy control".

```
Mode Extra Seq-  
uence Y4  
  
Not active
```

16.6 Extra sequence Y5

"Extra sequence Y5" can be configured to "Active" or "Not active".

```
Mode Extra Seq-  
uence Y5  
  
Not active
```

16.7 Heating coil

```
Heating  
water
```

The heater can be set to "Water", "Electric", "Water/Electric" or "Not used".
For detailed description of heater alternatives, see section 5.1.2 Heater types.

16.8 Exchanger

```
Exchanger
Rot. Exch
```

The heat exchanger unit can be set to one of the following alternatives:

- Plate exchanger
- Rotating exchanger
- Liquid connected exchanger
- Mixing dampers
- Not connected
- Damper limiting for minimum outdoor air percentage is settable 0...100%.

In the submenu parameters for outdoor temperature control of exchanger can be set.

```
Outd. temp control of
exch: Off
Outd. temp start: 10°C
Diff. stop: 0.2°C
```

For detailed description of exchanger alternatives, see section 5.1.3 Heat exchanger.

16.9 Chiller

```
Cooling
Water
```

Select chiller type: "Water", "DX", "DX with exchanger control" or "Not used".

For detailed description of DX-cooling, see section 5.1.4 Step controllers.

If DX cooling has been configured, there are submenus for setting of certain operation parameters.

Min limit lowering

If DX cooling is used in combination with room or extract air control, the supply air temperature minimum limit value can be lowered to give smoother (more continuous) running of the chillers. The set lowering of the limit value is activated when the DX cooling is running.

```
Lowering of min
limit for supply air
control on active
DX cooling: 5.0°C
```

This parameter is also used for setting the lowering of the cooling setpoint when running "DX cooling with exchanger control".

See 5.1.4.

Blocking the DX cooling at low outdoor temp

Outdoor temperature dependent blocking of DX cooling is individually settable for each cooling step. If the outdoor temperature is below the set value, it is not possible to activate the cooling step. The function has a 1K hysteresis, i.e. if a cooling step is blocked, it can only be activated again when the outdoor temperature has risen to 1K above the set value.

```
Block DX-cooling,  
step1, at outdoor temp.  
lower than 13.0 °C
```

Blocking of DX cooling on cooling pump alarm

DX cooling can be blocked on activation of the cooling pump alarm.

```
Block DX-cooling on  
alarm  
"Run error P1-  
cooler":No
```

Override of reduced speed for DX cooling

Override to normal quantity of air for DX cooling when the unit runs on reduced quantity of air. The fans can be set to normal operation when cooling is required at high outdoor temperatures (e.g. >14°C, the same temperature limit as for blocking of DX cooling).

```
Force normal  
speed if active  
DX-cooling:Yes
```

16.10 Pump control

```
P1-Heating      →  
P1-Exchanger    →  
P1-Cooling      →
```

In these menus the parameters for pump control are set.

If, for any of the control circuits, no output is configured for pump control these settings will be ignored.

P1 Heating

```
Pump stop: Yes  
Stop delay: 5 min  
Outd. Temp stop: 10°C  
Differential: 1.0°C
```

P1 Exchanger

```
P1-Exchanger  
Stop delay: 5 min
```

P1 Cooling

```
P1-Cooling  
Stop delay: 5 min
```

For a detailed description of pump functions, see the section Pump control.

16.11 Free cooling

```
Free cool active:Yes
Outd. temp activation
22.0°C
```

```
Outd. Temp night
    High: 18.0°C
    Low: 10.0°C
Room temp min 18.0°C
```

```
Hour for start/stop
Free cooling
Start: 0
Stop: 7
```

```
Time to block heat
output after
free cooling
60 min
```

```
Fan output
when free cooling
SAF: 0 %
EAF: 0 %
```

```
Outdoor sensor
placed in intake
channel
No
```

For detailed description, see section 5.1.6 Free cooling.

16.12 Support control

Note: If you select the function support control without EAF (extract air fan), a recirculation damper must be used. See more in section 5.1.5.

```
Support control
Active: Yes
EAF running during
support contr: Yes
```

Minimum running time

```
Min. run time for
support ctrl: 20 min
```

For detailed description, see 5.1.5 Support control.

16.13 CO2/VOC Demand control

```
CO2/VOC active
Never
Type: Mixing dampers
Min. time: 20 min
```

```
Activation level
1/2-speed: 800 ppm
1/1-speed: 1000 ppm
diff: 160 ppm
```

For detailed description, see the section Demand control.

16.14 Fire function

Fire dampers are normally configured to open on fire alarm. However, via the display you can configure them to be normally open instead.

In Corrigo controllers of generation 1, it was possible to choose whether the extract air fan should be activated on fire alarm or if both fans should be stopped.

For generation 2 controllers, you can use E tool[®] to configure the air handling unit's running mode on fire alarm. The following choices are possible: "stopped", "continuous run", "run via normal start/stop conditions", "only supply air fan in operation", "only extract air fan in operation".

For compatibility reasons, the old function has not been removed in generation 2 controllers. This means that old configuration files can be used in new Corrigo controllers as well. If the running mode in the new application has been set to another value than "stopped", this value will take precedence over the value in the old application.

As of software version 3.2, fire alarm priority has been altered so that the unit will not stop for any other alarm (e.g. frost protection) when it has been configured for continued operation during fire alarms. The digital input "external switch" will still stop the unit.

There is a digital input for detection of open and closed position of the fire dampers.

All dampers must be wired to the same output in order to get correct results.

```
Fire damper function
Not active
Operation when alarm
Stopped
```

Select if fire alarm should be normally closed or normally open and activation of fire damper exercising if the unit should be stopped or not: "No", "Yes unit running" →, "Yes unit stopped" →,

```
Fire alarm input
Normally open
Damper exercise
No
```

Set the parameters for damper exercise in the submenu.

```
Damper exercise
Running time: 90 sec
Interval in days: 1
Hour for exerc.: 00
```

Running time is the time the damper actuator needs to open or close.

Hour for exercise is the hour of the day at which you want the function to be run.

For detailed description of damper exercising, see the section Damper control.

16.15 Humidity control

Humidity control can be configured as either humidification or dehumidification or as combined humidification/dehumidification.

These settings are for the digital output "Humidification/Dehumidification".

```
Humidity control
Humid-/Dehumidificat
Start limit: 15%
Stop limit: 5%
```

For a detailed description, see the section Humidity control.

16.16 Exchanger de-icing

```
Exchanger de-icing
Yes
```

De-icing parameters

```
Setp.De-icing:-3.0°C
Hysteresis: 1.0 °C
Stoptemp SAF:-10.0°C
Min. run time: 5 min
```

For detailed description of exchanger alternatives, see section 5.1.3 Heat exchanger.

16.17 Cooling recovery

```
Cooling recovery
Off
Cooling limit: 0.0°C
```

Cooling limit is the difference in temperature between extract air and outdoor air.

For details, see section 5.1.7 Cooling recovery.

16.18 Minimum limit dampers

```
Min limit dampers
Not active
Min limit.: 5%
```

For detailed description of exchanger alternatives, see section 5.1.3 Heat exchanger.

16.19 Enthalpy control

```
Cooling recovery
run when enthalpy is
greater outdoor than
indoor : Active
```

For a detailed description, see section 5.1.8 Enthalpy control.

16.20 External setpoint

An external setpoint device, for example TBI-PT1000 or TG-R4/PT1000 can be connected. The setpoint device must follow the PT1000 resistance curve. The setting range can be restricted.

```
External setpoint
Not active
Min setp.: 12.0°C
Max setp.: 30.0°C
```

For details, see section 5.1.10 External setpoint.

16.21 Run indication / Motor protection

Digital input signals are used to supervise fans and pumps. They can be configured either for indication of the motor running or for monitoring of motor protection contacts.

An input configured for run indication should normally be closed during operation.

Open input when the motor is running, i.e. motor control output is activated, will generate an alarm.

For supply air fans and extract air fans, there is also a conflict alarm, i. e. an alarm if the run indication input is closed even though the motor control output is not activated. See alarm 33 Supply Air Fan external operation and alarm 34 Extract Air Fan external operation in the section Alarm configuration.

An input configured as motor protection should be normally open, i. e. closed contact when the motor is running, i.e. motor control output is activated, will generate an alarm.

```
Run ind./Motor prot
SAF: Motor protection
EAF: Motor protection
```

```
Run ind./Motor prot
P1 Heat: Motor
protection
P1 Exch: Motor
protection
P1 Cool: Motor
protection
```

When running frequency controlled fans, the pressure signal from each respective fan's pressure transmitter is normally used as run indication signal. If the pressure falls below the set value during normal operation, a malfunction alarm is activated.

```
Min pressure for
run indication
SAF: 25.0 Pa
EAF: 25.0 Pa
```

Alarm from frequency converter

When running frequency controlled fans, you sometimes want to use both a pressure signal from a pressure transmitter and a digital alarm signal from a frequency converter. An analogue input for a pressure transmitter *and* a digital input for "SAF Indication" or "EAF Indication" must then be configured. The setting "Run indication/Motor protection SAF" or "EAF Indication" must be set to "Motor protection". A fan alarm will be activated both when there is no pressure signal from the pressure transmitter, and when the digital signal "SAF Indication" or "EAF Indication" is activated.

16.22 Actuator type

Choose output signals to the actuators connected to the analogue control outputs: 0...10 V DC, 2...10 V DC, 10...0 V DC or 10...2 V DC.

```
Actuator type
Y1 Heating: 0-10V
Y2 Exchan.: 0-10V
Y3 Cooling: 0-10V
```

```
Actuator type
  SAF: 0-10V
  EAF: 0-10V
  Split: 0-10V
```

```
Actuator type
Y6 Humidity: 0-10V
Extra unit: 0-10V
Y1 Heat/Y3 cool 0-10V
```

```
Actuator type
Y4 Extra seq.: 0-10V
```

```
Actuator type
Y5 Extra seq.: 0-10V
```

NOTE: Even though many manufacturers state 0...10 V DC as control signal for many actuators, the *actual* control signal is more often than not 2...10 V DC. Check the actuator documentation carefully. If uncertain, choose 0...10V DC. Although control might be less accurate, it will ensure that the valve always can be driven to its fully opened and fully closed positions.

16.23 Running time, 3-position actuators

These parameters have no function if analogue actuators are configured.

The values are used to determine the control parameters for 3-position actuators.

It is important to set correct values since incorrect values lead to sloppy control.

```
Actuator run time
Heating: 255 sec
Exchanger: 255 sec
Cooling: 255 sec
```

16.24 Step controllers

```
Step contr. heating →
Step contr. Cooling →
```

16.24.1 Step controller heating

Step controller heating can be set to sequential or binary.

```
Step contr. heating
Activation levels →
Binary steps →
```

Step controller Heating activation levels for sequential control.

For binary control the activation levels are calculated by the controller depending on the number of steps involved

```
Start step 1: 10 %
Stop step 1: 5 %
Start step 2: 45 %
Stop step 2: 40 %
```

```
Start step 3: 70 %
Stop step 3: 65 %
Start step 4: 95 %
Stop step 4: 90 %
```

Control parameters. Heater groups is used to calculate activation levels for binary control. "Hyst." is the switching differential used for each step when running binary control.

```
Heater groups: 4
Minimum on/off-
time: 60 sec
Hyst.: 0.5 %
```

16.24.2 Step controller cooling

"Step controller Cooling" can be set to sequential or binary.

```
Step contr. cooling
Sequential →
```

"Step controller Cooling" activation levels for sequential control.

For binary control the activation levels are calculated by the controller depending on the number of steps involved

```
Start step 1: 10 %
Stop step 1: 5 %
Start step 2: 50 %
Stop step 2: 45 %
```

```
Start step 3: 95 %
Stop step 3: 90 %
```

Control parameters. Chiller groups is used to calculate activation levels for binary control. "Hyst." is the switching differential used for each step when running binary control.

```
Chiller groups: 3
Minimum on/off-
time: 60 sec
Hyst.: 0.5 %
```

When DX cooling is used in conjunction with pressure controlled or flow controlled fans it is possible to block DX cooling if the supply air fan control signal falls below a preset values. The blocking level is individually settable for each DX cooling step.

```
At lower SAF-output
block step 1: 0 %
block step 2: 0 %
block step 3: 0 %
```

For a more detailed description, see section 5.1.4 Step controllers.

16.24.3 Step controllers Change-over

The digital output signals "Heating/cooling step 1", "Heating/cooling step 2" and "Heating/cooling step 3" are used for step controllers during Change-over control (see section 5.1.12). They have the same functions as other step controller outputs, but are set to either heating or cooling depending on whether heating or cooling is required. In other words, when heating is active, they will follow the settings for "Heating 1-3" and when cooling is active they will follow the settings for "Cooling 1-3".

16.25 Recirculation

Recirculation is a function for distributing the air in the room using the supply air fan. The extract air fan can also be used, if desired. The function can be used even when there is no heating or cooling demand. When using recirculation control, the extract air fan stops and a recirculation damper opens which allows the air to circulate through the unit.

```
Enable temp control
when recirculation:
No
```

Recirculation control can be configured as either air circulation (temperature control inactive) or air circulation with temperature control. (Only heating, only cooling or both heating and cooling.) Recirculation control can either have a unique setpoint or follow the supply air setpoint, with an adjustable offset. The other settings are the same as for normal operation, i.e. if normal operation has been configured as room control, room control will also be used during recirculation.

```
End recirculation
control when room
temp. exceeds:
25.0°C
```

If the room temperature rises above the set limit value, recirculation will be stopped.

```
Enable free cool
when recirculation:
No
```

To lower the temperature, it is possible to configure free cooling to be used during recirculation, if the conditions for free cooling are fulfilled.

```
Use extra time
group 5 to start
recirculation: No
```

Recirculation is activated either via a digital input signal or by connecting it to "Timer output 5".

```
EAF in operation at
recirculation: No
```

The extract air fan can be selected to run during recirculation.

16.26 Pretreatment

Control of dampers and pump for preheated or pre-cooled outdoor air via an underground intake channel. The digital output "Pretreatment" is set to preheating when the unit is started and the outdoor temperature is below the set heating start limit (default 8°C) or to precooling when the outdoor temperature is above the set cooling start limit (default 19°C).

If the outdoor temperature exceeds the set heating start limit by more than 1°C (fixed), preheating will be aborted, as well as if the outdoor temperature falls below the cooling start limit by 1°C.

If a sensor is configured in the intake duct ("intaketemp") this temperature will be compared with the outdoor temperature. If the temperature in the intake duct does not exceed the outdoor temperature by more than 1°C (adjustable) 5 minutes (fixed) after start-up when using preheating, preheating will be aborted. The same conditions apply to precooling, i.e. if the intake temperature is not more than 1°C (adjustable) cooler than the outdoor temperature, precooling will be aborted.

Pretreatment always starts at start-up of the unit, if the outdoor temperature so permits. If pretreatment is aborted due to a small difference between the intake temperature and the outdoor temperature, pretreatment will be blocked for 6 hours. Then pretreatment will start (if the outdoor temperature so permits) and run for at least 5 minutes.

```

Outdoortemp for
activating
preheating: 8.0 °C
precooling: 19.0°C

```

```

Minimum diff.
outdoortemp-
intaketemp: 1.0°C

```

16.27 Alarm setting

Permits configuration of all alarms.

Select the appropriate alarm number (from the alarm list). The alarm text for the alarm will be displayed and the alarm priority can be set; "A-alarm", "B-alarm", "C-alarm" or "not active". The extra stop function gives, for each alarm, the option to stop or not stop the unit on alarm activation.

```

Run Error supply air
Priority: B-alarm
Extra stop function
Active

```

Alarm text

The alarm text that should be shown in the display when there is an alarm can be changed using E tool[®]. For more information, see the E tool[®] manual.

Alarm list

The alarm text and priority columns show the factory set values.

	Alarm text	Pri	Description
1	Run Error Supply Air Fan	B	Malfunction Supply air fan
2	Run Error Extract Air Fan	B	Malfunction Extract air fan
3	Run Error P1-Heater	B	Malfunction pump, Heating circuit
4	Run Error P1-Cooler	B	Malfunction pump, Cooling circuit
5	Run Error P1-Exchanger	B	Malfunction pump, Liquid connected exchanger
6	Filter guard	B	Filter guard pressure switch activated
7	Flow switch	B	Flow switch activated
8	External frost guard	A	External Frost protection thermostat activated
9	Deicing pressure guard	-	Exchanger de-icing pressure switch activated
10	Fire alarm	A	Fire alarm activated

	Alarm text	Pri	Description
11	External switch	C	"External switch" activated
12	External alarm	B	External alarm activated
13	Supply Air control error	B	Supply air temp deviates too much from the setpoint for too long.
14	Humidity control error	-	The room humidity deviates too much from the setpoint.
15	High supply air temp	B	Supply air temp too high
16	Low supply air temp	B	Supply air temp too low
17	Supply air temp max	-	Maximum limiting of supply air temp active
18	Supply air temp min	-	Minimum limiting of supply air temp active
19	High room temp	B	Room temp too high during room temp control
20	Low room temp	B	Room temp too low during room temp control
21	High extract air temp	B	High extract air temp during extract air control
22	Low extract air temp	B	Low extract air temp during extract air control
23	Electric heating is overheated	A	Heater high temperature limit switch activated
24	Frost risk	B	Frost protection function is overriding the control of the heater output
25	Low frostguard temp	A	Frost protection temperature below frost limit value
26	Low efficiency	B	Heat exchanger efficiency below limit value
27	Sensor error Outdoor temp	B	Malfunction of connected sensor
28	Analogue de-icing	-	Exchanger de-icing activated by de-icing sensor
29	Rotation guard exchanger	B	Exchanger rotation sentinel alarm activated
30	Fire damper is out of operation	B	Fire damper exercise test failed
31	Supply Air Fan control error	-	Supply air pressure deviates too much from the setpoint for too long.
32	Extract Air Fan control error	-	Extract air pressure deviates too much from the setpoint for too long.
33	Supply Air Fan external operation	C	SAF run-signal received when unit is stopped
34	Extract Air Fan external operation	C	EAF run-signal received when unit is stopped
35	Ventilation Manual mode	C	The unit is in manual mode
36	Manual supply air control	C	Supply air temp controller in manual control
37	Manual supply Air Fan mode	C	Supply air fan in manual control
38	Manual Supply Air	C	The SAF is in manual mode
39	Manual Extract Air Fan mode	C	Extract air fan in manual control
40	Manual Extract Air	C	The EAF is in manual mode
41	Manual Heater Control	C	The heater is in manual mode
42	Manual exchanger control	C	Heat exchanger output in manual control
43	Manual cooler control	C	Cooling output in manual control

	Alarm text	Pri	Description
44	Manual P1-Heater	C	Heating circulation pump in manual control
45	Manual P1-Exchanger	C	Exchanger circulation pump in manual control
46	Manual P1-Cooler	C	Cooling circulation pump in manual control
47	Fire damp. Manual	C	Fire dampers in manual control
48	Internal battery error	A	Internal battery needs replacing
49	Sensor error Supply Air temp	B	Malfunction of connected sensor
50	Sensor error Extract Air temp	B	Malfunction of connected sensor
51	Sensor error Room temp 1	B	Malfunction of connected sensor
52	Sensor error Room temp 2	B	Malfunction of connected sensor
53	Sensor error Exhaust air temp	B	Malfunction of connected sensor
54	Sensor error Extra sensor	B	Sensor error Extra sensor 1
55	Sensor error SAF pressure	B	Malfunction of connected sensor
56	Sensor error EAF pressure	B	Malfunction of connected sensor
57	Sensor error Deicing temp	B	Malfunction of connected sensor
58	Sensor error Frost Protection temp	B	Malfunction of connected sensor
59	Sensor error CO ₂	B	Malfunction of connected sensor
60	Sensor error Humidity Room	B	Malfunction of connected sensor
61	Sensor error Humidity Duct	B	Malfunction of connected sensor
62	Sensor error Extra unit temp	B	Malfunction of connected sensor
63	Sensor error External control SAF	B	Malfunction of connected sensor
64	Sensor error External control EAF	B	Malfunction of connected sensor
65	Sensor error SAF Pressure 2	B	Malfunction of connected sensor
66	Sensor error Humidity outdoor	B	Malfunction of connected sensor
67	Sensor error Intake temp	B	Malfunction of connected sensor
68	Sensor error Extra sensor 2	B	Malfunction of connected sensor
69	Sensor error Extra sensor 3	B	Malfunction of connected sensor
70	Sensor error Extra sensor 4	B	Malfunction of connected sensor
71	Sensor error Extra sensor 5	B	Malfunction of connected sensor

	Alarm text	Pri	Description
72	Sensor error Extra SAF pressure	B	Malfunction of connected sensor
73	Sensor error Extra EAF pressure	B	Malfunction of connected sensor
77	Alarm frequency converter SAF	A	Malfunction of frequency converter SAF
78	Alarm frequency converter EAF	A	Malfunction of frequency converter EAF
79	Communication error Frequency SAF	C	Communication error Vacon NXL/Lenze SMV/Omron V1000/Emerson
80	Communication error Frequency EAF	C	Communication error Vacon NXL/Lenze SMV/Omron V1000/Emerson
81	Communication error Expansion unit 1	C	Communication problem with a controller connected to port2
82	Communication error Expansion unit 2	C	Communication problem with a controller connected to port2
83	Warning Frequency converter SAF	C	Alarm from frequency converter via Modbus communication
84	Warning Frequency converter EAF	C	Alarm from frequency converter via Modbus communication
85	Output in manual mode	C	Analogue or digital output in manual mode
86	Time for service	C	Time for service
87	Manual Y4-Extra Sequence control	C	Y4-Extra sequence in manual control
88	Restart blocked after power on	B	Restart blocked due to earlier power failure
89	Manual Y5-Extra Sequence control	C	Y5 Extra sequence in manual control

16.28 Communication

16.28.1 Modbus communication

Corrigo E can be connected to a network for Modbus communication. You do not need an activation code.

```
Modbus slave com-  
munication, Port 1  
Not Active
```

If Modbus communication is activated, you can set the address etc.

Modbus communication takes place using 1 stop bit.

```
Modbus Address: 1  
Speed: 9600 bps  
Two stop bits:Yes  
Parity:No
```

Note: Only one stop bit can be used.

16.28.2 Function port 2

Units connected to port two can be set to "Slave", "Master", "Expansion unit", "Modbus master" or both "Expansion unit and Modbus master". A 2-port Corrigo is required. Port two is then used for communication with the expansion units or frequency converters. This port is also used to connect an external display/room unit.

Slave

For connection to E tool[®] and a Modbus SCADA system.

```
Function Port 2  
Slave
```

Master

For future use.

```
Function Port 2  
Master
```

Modbus master

For control of up to two Vacon NXL/Lenze SMV/Omron V1000/Emerson Commander/ LS iG5a / LS iS7 / EBM-PABST frequency converters using Modbus communication. Miscellaneous alarms and indications can be read from the frequency converters. For a complete list of alarms, see the alarm list. For communication addresses, see the Corrigo variable list. Information is also available at the end of this manual.

The Corrigo Modbus settings are listed below. They are not adjustable and must also be set in the Vacon NXL/Lenze SMV/Omron V1000/Emerson Commander/ LS iG5a / LS iS7 / EBM-PABST frequency converters.

Modbus address: Supply air fan = 1, Extract air fan = 2
Speed: 9600 bps, 1 stop bit, no parity

For additional settings for every model, see appendix 1 at the end of this document.

```
Type of frequency
converter connected
via Modbus:
Vacon NXL
```

Expansion unit

In order to connect additional I/Os (in- and outputs) to the Corrigo, port two should be set as an expansion unit (only Corrigo E controllers can be connected). It is possible to connect two units, giving a maximum number of 28*3 = 84 inputs/outputs. The expansion units must have the addresses 241:1 and 241:2 respectively (ELA:PLA).

```
Expansion unit 1
None
Expansion unit 2
None
```

To initiate the expanded controllers, select "Expansion unit" at start-up (see below). If the controller does not contain program version 3.0 or later, the initiation must be made via E tool[®] (see the E tool[®] manual). However, this requires that the controller hardware is of a Corrigo generation 2 (-S). After initiating the expansion units and setting the master controller, all inputs and outputs are available for configuration in the master controller under "Configuration" / "Inputs/Outputs" (the expansion units' in-/outputs are named Exp1/Exp2).

```
Ventilation
Heating
Boiler
Expansion Unit 1
Expansion Unit 2
```

Expansion unit and Modbus master

Frequency converters can be used in combination with expansion units on the same port. The master controller will switch the port between Modbus and EXOline in order to communicate with the frequency converters via Modbus and with the expansion unit via EXOline.

```
Function Port 2
Exp. and Modbusmaster
```

Press RIGHT to select which expansion units are to be connected.

```
Expansion unit 1
None
Expansion unit 2
None
```

Then go a step down to select which frequency converters are to be connected. For additional settings for frequency converters, see appendix at the end of this document.

```
Type of frequency
converter connected
via Modbus:
None
```

16.28.3 Dial-up modem

With the help of a dial-up modem, Corrigo E can be connected to a supervisor EXO-system. We recommend the modem Modem56kINT485kit. The default password is exo.

```
DialUpModem: No
Number:
Password:
exo
```

16.28.4 Alarm forwarding via SMS

Via a connected GSM modem, Corrigo can send an A-alarm message to up to three different recipients. You do not need an activation code to use this function. The alarm message consists of an alarm text, the unit name (the same text that is shown in the first row of the start display) and the time when the alarm occurred. When there is an alarm, the message is sent to the first number on the list. If the recipient does not send an empty SMS within five minutes to confirm that the message has been received, Corrigo will send the message to the next number on the list.

```
SMS: Not Active
Nbr1:
Nbr2:
Nbr3:
```

16.29 Other parameters

16.29.1 Start and stop delays for the fans

Use start delay if you wish one of the fans to start before the other and for example if you wish to give the close-off dampers time to open before starting the fans. Use stop delay e.g. to create a cool-down period when using electric heating. In order to avoid letting in too cold air, e.g. in the winter, the heat exchanger will continue to run during the stop delay.

```
Delay SAF
Start: 60 sec
Stop: 30 sec
```

```
Delay EAF
Start: 0 sec
Stop: 30 sec
```

16.29.2 Retardation time

When switching two-speed fans from 1/1-speed to 1/2-speed there is a settable retardation time. The same time applies to both fans.

```
Retardation time
1/1-1/2speed: 10 sec
```

16.29.3 Heating at start-up and high speed blocking

At outdoor temperatures below the set value, the heating output will be forced to 100% before start-up.

Two speed fans and pressure controlled fans can be blocked from using high speed at outdoor temperatures lower than the set value. This function should not be combined with the function "Outdoor compensation of pressure setpoint". See the section Demand control.

Both functions need an outdoor temperature sensor.

```
Outd.temp for
heat start: 3.0°C
Blocking of
1/1-speed: -10°C
```

16.29.4 Start delay exchanger

```
Startdelay Exch.  
0 sec
```

16.29.5 Exchanger to 100% at start and alarm delay at start

To minimise the risk of freeze-up problems, the heat exchanger can be forced to maximum capacity for the set time at start-up.

To eliminate the risk of, for example, fan pressure alarms at start-up, all alarm functions can be suppressed for the set time.

```
Exch 100% at start  
2 sec  
Alarm delay at start  
60 sec
```

For the function "Slave control of the extract air fan", the fan will start directly at 50 % after the start delay, in order for the heating of the exchanger to work for this operating mode. When the supply air fan starts, the extract air fan will be slave controlled by the flow in the supply air duct.

16.29.6 Split controller signal

Splits the controller output (Heating Controller Output signal = HCO_{out}) between the analogue temperature control output signals Y1, Y2 and Y3 for "Heating", "Heat exchanger" and "Cooling".

To create a neutral zone, leave a percentage gap between sequences.

The set P-band for the supply air controller is for the whole controller signal. This means that the P-band for each sequence is proportionate to the split percentage values given to sequences.

Example:

P-band for the supply air controller is set to 33K. The HCO_{out} is set so that cooling gets 0...30 % = 30 %, the exchanger gets 32...50 % = 18 % and the heater gets 54...100 % = 46 %. The individual P-bands will then be:

Chiller: 30 % of 33°C = 10°C

Exchanger: 18 % of 33°C = 6°C

Heating: 46 % of 33°C = 15°C

The remaining 2°C are the neutral zone between cooling and exchanger.

```
Split settings  
Exchanger  
0% at HCOout= 32%  
100% at HCOout= 50%
```

```
Split settings  
Heating  
0% at HCOout= 54%  
100% at HCOout= 100%
```

```
Split settings  
Cooling  
0% at HCOout= 30%  
100% at HCOout= 0%
```

```

Split settings
Extra Sequence Y4
  0% at HCOut= 0%
 100% at HCOut= 0%

```

```

Split settings
Extra Sequence Y5
  0% at HCOut= 0%
 100% at HCOut= 0%

```

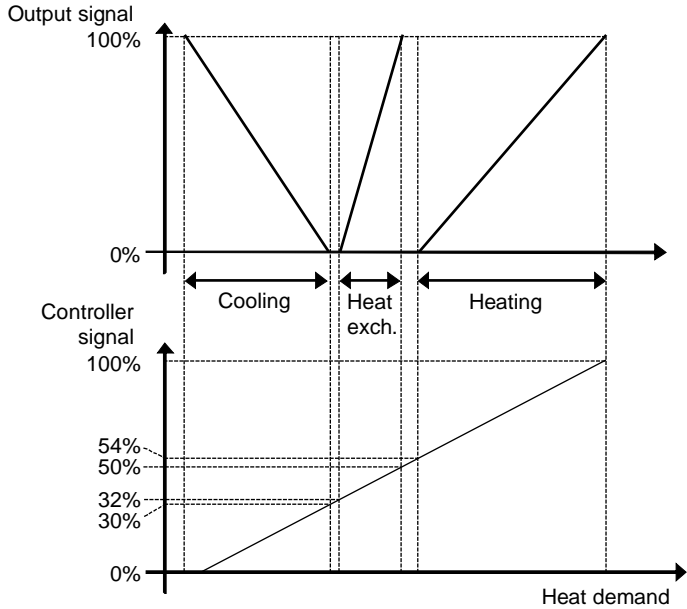

16.29.7 Outdoor temp. for control mode change

If the unit is configured for combined Supply air/Room control this menu permits the setting of the change-over outdoor temperature.

```

Outdoor temp for
control mode change
13.0°C

```

16.29.8 Split of optional temp. sequence

Any one of the analogue temperature control output sequences "Y1", "Y2" and "Y3", "Y1 Heating/Y3 Cooling", "Y4-extra sequence" or "Y5-extra sequence" can be split, for example to control two heating valves in sequence. The split is always even, 50/50, which means that each part of the split will have half the part of the P-band assigned to the output. An analogue output must be assigned to the output signal "Split". On increasing output demand, the regular output is always run first and then the output that has been configured as Split.

```

Split optional
temperature sequence
Y1 Y2 Y3
No split

```

16.29.9 Fast stop on overheating

If this function is active, the fans will be immediately stopped when there is an overheating alarm, regardless of the set cool-down time.

```
Fast stop on alarm
"Electric heating is
overheated": No
```

16.28.10 Automatic restart at power-up

The function "Automatic restart at power-up" makes it possible to block automatic restart of the unit at power-up. At power-up, the B-alarm "Restart blocked after power on" is generated. Once this alarm has been acknowledged, the unit will start.

```
Automatically
restart after
power on:
Yes
```

16.30 System

16.30.1 Change language

Use this menu to change the display language.

```
Choose language
English
```

Note, this menu is also directly accessible by holding the OK-button depressed during power-up or by pressing right arrow three times when the start display is shown.

The different language files are stored in the application memory and are downloaded to the work memory. If a Corrigo via E tool[®] has been reloaded with a newer program revision than the factory revision, the controller will not allow language files to be downloaded from the application memory. This is because there is a risk that the language files are not compatible with the new revision. Therefore, you are limited to the two languages you have downloaded using E tool[®].

16.30.2 Choose start display, the text normally shown on the display

There are five different to choose from.

Type 1

The text on the first line can be changed using E tool[®].

The second line shows the date and time.

The third line shows the present running status.

The fourth line shows the present temperature setpoint and actual values.

```
Vent unit 18 PX
2004-08-15 11:28
System: Running
Sp:22.0°C Act:21.8°C
```

Type 2

The first line shows the date and time.

The second line shows the present running status.

The third line shows the present temperature setpoint and actual values.

The fourth line shows the present temperature control output values.

```
2004-08-15 11:28
System: Running
Sp:22.0°C Act:21.8°C
Y1:0% Y2:93% Y3:0%
```

Type 3

The first line shows the date and time.

The second line shows the present running status.

The third line shows the present temperature setpoint and actual values.

The fourth line shows the present SAF and EAF pressures.

```
15/03/2004 11:28
System: Running
Sp:22.0°C Act:21.8°C
SAF:1100Pa EAF:1050Pa
```

Type 4

The text on the first line can be changed using E tool[®].

The second line shows the date and time.

The third line shows the present running status.

```
Vent unit 18 PX
2004-03-15 11:28
System: Running
```

Type 5

The text on the first line can be changed using E tool[®].

The second line shows the date and time.

```
Vent unit 18 PX
2004-03-15 11:28
```

16.30.3 Automatic summer-/wintertime change-over

When Corrigo is set on automatic summertime/wintertime change-over, the timer will automatically change between summertime and wintertime according to European standard.

```
Automatic summer/
winter time change
over
Yes
```

16.30.4 Address

Corrigo E uses the addresses below when connecting to Corrigo E tool[®], and when multiple controllers are connected in an EXO network. E tool[®] normally uses the addresses below, so if an address is changed, the new address must also be entered in E tool[®]. If several Corrigo are connected in a network, all the units must have the same ELA address, but each unit must have a unique PLA address.

```
Address
PLA: 254
ELA: 254
```

16.30.5 Display anywhere (Remote control)

If multiple Corrigo units are connected in a network, it is possible to remote control a unit in the network from a unit with display. You do this by entering the address of the unit you wish to remote control in the unit with display. The function is aborted by pressing the buttons UP, OK and DOWN simultaneously.

```
Address for remote
communication
(PLA:ELA) : 00:00
```

16.30.6 Automatic logoff

If the access level is Operator, Service or Admin, the user will automatically be logged off to Normal after a settable time of inactivity. The time is settable in units of 5 seconds. Standard 60 units = 5 minutes.

The automatic logoff can be removed, see 8.4.

```
Time before user
automatically
logged off:60
(Unit 5 sec)
```

16.30.7 Activation of start-up wizard

The start-up wizard is a special program which at the first start-up guides the operator through a number of start-up menus where you set certain operation parameters. For more information, see the section Start-up wizard.

```
Activate wizard
No
```

Chapter 17 Expansion model

There are eight different 2-port Corrigo models with 15/28 inputs/outputs, with or without display, and with or without TCP/IP port. For a list of the different models, see the Corrigo E model overview in chapter 2.

17.1 Port 1

On a 2-port Corrigo, port one is used for connection to E tool[®] and possibly a SCADA system. On an Exx2S-WEB model, port 1 is the TCP/IP output.

17.2 Port 2

Port 2 is used for expansion units, e.g. expansion units and the Vacon NXL/Lenze SMV/Omron/Emerson frequency converters. A maximum of two frequency converters and two expansion units can be connected. If set as slave, port 2 can also be used with E tool[®]. The controllers must be of the type Corrigo E. There is no point in utilising slave units with display since the display cannot be used or show anything. However, an external display is required when starting up slave controllers without display for the first time (if the configuration is not done via E tool[®]). All configuration takes place either via E tool[®] or via the display on the master controller. All inputs and outputs can be viewed in the master controller. For configuration of port 2, see section 16.27.2.

From version 3.1, frequency converters and expansion units can be used together, connected to port 2.

17.3 Wiring

17.3.1 Vacon/Lenze/Omron/Emerson/LS/EBM frequency converters

If the Corrigo is intended to control of one or two of the Vacon NXL/Lenze SMV/Omron V1000/Emerson frequency converters, Modbus communication via port two is utilised.

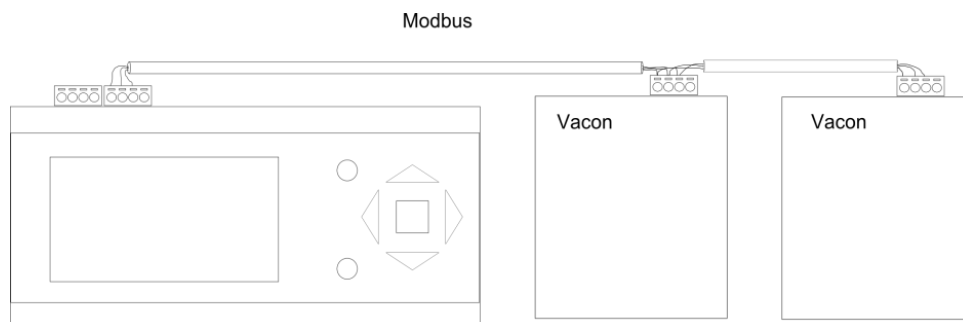

For additional settings for frequency converters, see appendix at the end of this document.

17.3.2 Expansion units EXOline

Communication between the master and expansion units takes place via EXOline. The slave controllers will be given the addresses 241:1 and 241:2 (ELA:PLA) respectively.

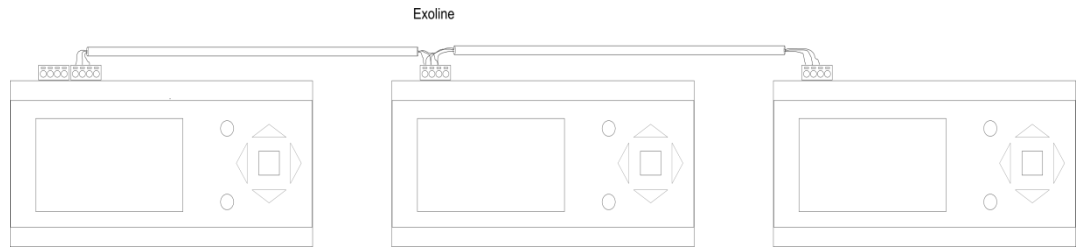

17.3.3 Expansion units LON

For a 2-port Corrigo to be able to communicate via LON, the first expansion unit must have a LON port. Communication between the master and expansion units takes place via EXOline.

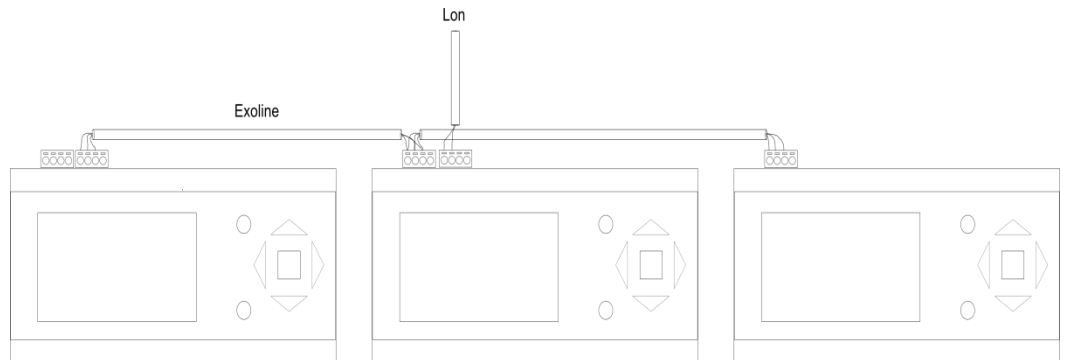

Chapter 18 Other functions

18.1 Alarm handling

If an alarm condition occurs, the red Alarm LED on the front panel of units with display or the Alarm LED on a connected display unit will start flashing. The LED will continue to flash as long as there are unacknowledged alarms.

Alarms are logged in the alarm list. The list shows type of alarm, date and time for the alarm and the alarm class (A, B or C alarm).

To access the alarm list, press the alarm button, the front panel button with the red button-top.

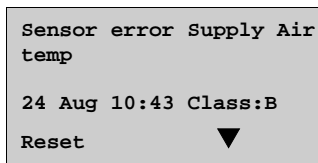

```
Sensor error Supply Air
temp
24 Aug 10:43 Class:B
Reset ▼
```

If there are multiple alarms, this is indicated by up/down arrow symbols at the right-hand edge of the display.

Use the UP and DOWN buttons to access the other alarms.

At the left end of the bottom display line the alarm status is shown. For active, unacknowledged alarms the space is blank. For alarms that have reset the text “Reset” is shown. Acknowledged, still active or blocked alarms are indicated by Acknowledged or Blocked.

Alarms are acknowledged by pressing the OK button. You are then given the choice of acknowledging the alarm or blocking the alarm.

Acknowledged alarms will remain on the alarm list until the alarm input signal resets. The LED is then lit.

Blocked alarms remain on the alarm list until the alarm has reset and the block has been removed. New alarms of the same type will not be activated as long as the block remains.

Since blocking alarms can be potentially hazardous, you need a high user access to block alarms.

Class A and B alarms will activate alarm output(s) if these have been configured.

Class C alarms do not activate the alarm output(s).

Class C alarms are removed from the alarm list when the alarm input resets even if the alarm has not been acknowledged.

18.2 Free text

If RIGHT is pressed once when the start-menu is shown, a menu showing text of your choice is displayed. The text can be used to show information concerning the commissioning company, name and phone number to service personnel etc. The easiest way to enter text is to use E tool[®], but the buttons can also be used. Four lines of 20 characters.

18.3 Revision number

If RIGHT is pressed twice when the start-menu is shown, a menu showing the program revision number, i.e. the date on which the program was created, and the Corrigo ID number (not to be confused with its serial number) is displayed.

18.4 Language



When the start menu is displayed, pressing the RIGHT button three times will display a menu in which the language can be changed.

The different language files are stored in the application memory and are downloaded to the work memory. If a Corrigo via E tool[®] has been reloaded with a newer program revision than the factory revision, the controller will not allow language files to be downloaded from the application memory. This is because there is a risk that the language files are not compatible with the new revision. Therefore, you are limited to the two languages you have downloaded using E tool[®].

18.5 Indication LEDs

Status indication can be found in the upper left corner of the master controller. For controllers with display, the alarm indication and change mode LEDs are located in the keypad area.

Status indication

Designation	Colour	Description
Tx	Green	Port 1, Transmitting
Rx	Green	Port 1, Receiving
Serv (-LON models)	Yellow	Service LED LON, commissioning
LAN (-WEB models)	Yellow/Green	Green: Connected to other network equipment Blinking green: Network traffic Blinking yellow: For identifying
P/B (Power/Battery)	Green/Red	Power on/Battery error
Controllers with built-in display:		
	Red	Alarm indication
	Yellow	Change mode

18.6 Changing the battery

This procedure requires knowledge of proper ESD protection; i.e. an earthed wristband must be used!

When the alarm "Internal Battery" is activated and the battery LED lights up red, the battery for backup of program memory and real-time clock has become too weak. The battery is replaced as described below. A backup capacitor saves the memory and keeps the clock running for at least 10 minutes after the power supply is removed. Therefore, if the battery replacement takes less than 10 minutes, there will be no need to reload the program, and the clock will continue to run normally.

The replacement battery must be of the type CR2032.

Remove the cover by pressing down the locking torques at the edge of the cover using a small screwdriver, and at the same time pulling the edges outwards.

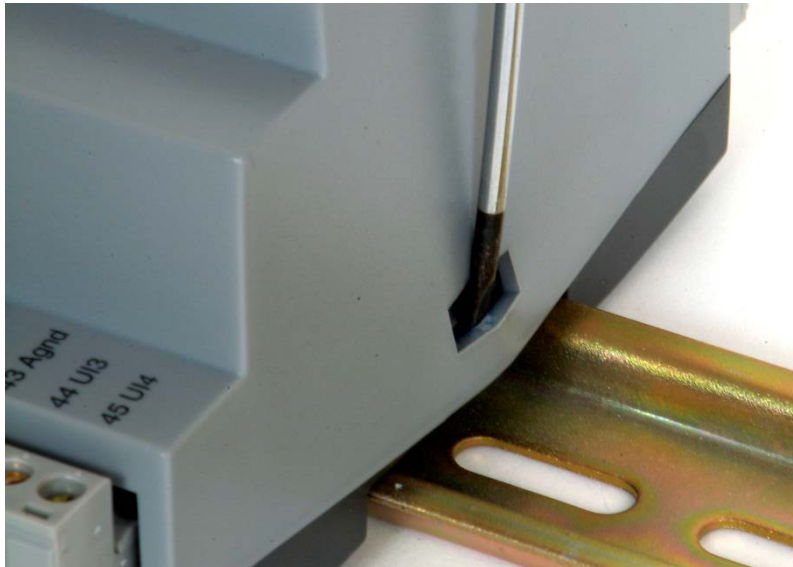

Battery location

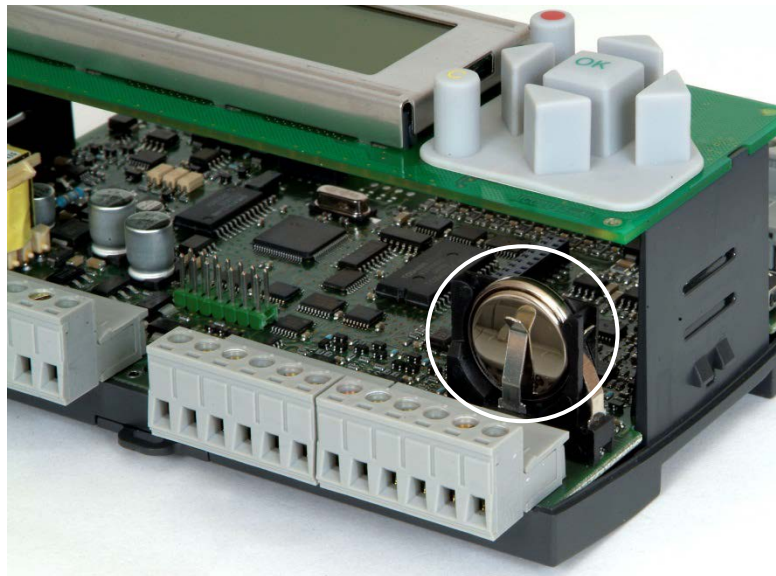

Grip the battery firmly with your fingers and lift it upwards until it rises from its holder.

Press the new battery firmly down into place. Note that to preserve correct polarity, the battery can only be inserted the “right way round”.

18.7 Start-up wizard

The start-up wizard is a function that can be activated in "Configuration"/"System". See the section Activation of start-up wizard.

If the wizard has been activated, the operator will access a number of menus at power-up. These menus contain certain operation parameters that should be set.

The wizard is useful when the controller is delivered pre-configured together with an air handling unit. After the controller has been configured, the manufacturer of the air handling unit will activate the start-up wizard, which will help the operator to set setpoint values, running times etc. without having to log on.

In the first menu, the language is chosen.

```
Choose language
English
```

In the second menu, the setpoint is set. The appearance of the menu depends on which control type has been configured.

```
Supply air temp
Setp.: 18°C
```

In the third menu, time and date are set.

```
Time: 14:27
Date: 2008-11-25
Weekday: Tuesday
```

In the fourth menu, the running time for normal speed Monday – Friday is set.

```
Normal speed
Monday → Friday
Per 1: 07:00 - 16:00
Per2: 00:00 - 00:00
```

In the fifth menu, the running time for normal speed Saturday, Sunday and holiday is set.

```
Normal speed
Saturday → Holiday
Per 1: 00:00 - 00:00
Per2: 00:00 - 00:00
```

If 2-speed fans or pressure/flow controlled fans have been configured, the corresponding times for reduced speed will be displayed in the sixth and seventh menus.

```
Reduced speed
Monday → Friday
Per 1: 07:00 - 16:00
Per2: 00:00 - 00:00
```

```
Reduced speed
Saturday → Holiday
Per 1: 00:00 - 00:00
Per2: 00:00 - 00:00
```

The last menu is used to turn off the wizard, and the Corrigo will switch to normal running mode. The selected values will be used.

The wizard will not be shown again during further use.

18.8 Energy calculation

The total energy consumption of the air handling unit can be obtained by internally calculating the various partial outputs of system components. By combining the various outputs of heaters/coolers, fans, etc., current power consumption is calculated based on their combined output.

18.9 SFP (Specific Fan Power)

If fans are used that are controlled by frequency converters connected via Modbus and which also supply information on motor output, the Corrigo is capable of calculating SFP using the following formula:

$$\text{SFP} = \text{Total effect from both fans} / \text{Supply air fan flow in kW} / (\text{m}^3/\text{s}).$$

“Extra pressure transmitter supply air” is always used to measure flow, if connected. Otherwise “SAF Pressure” will be used or, alternatively, “SAF Pressure 2” if fan control is “Frequency control SAF with EAF flow control”.

Power loss as a percentage of the frequency converter can be added for calculating the total output. If, for instance, power loss is 5 %, the total output will be as follows:

$$\text{Total output} = (\text{Supply air fan output} + \text{Extract air fan output}) \times 1.05.$$

A daily and a monthly average (always 30 days) are also computed and presented in the display and in E tool[®]. SFP for the average values is calculated only when the unit is running.

The display image can be located under the menu **Running mode**→**Running mode unit**:

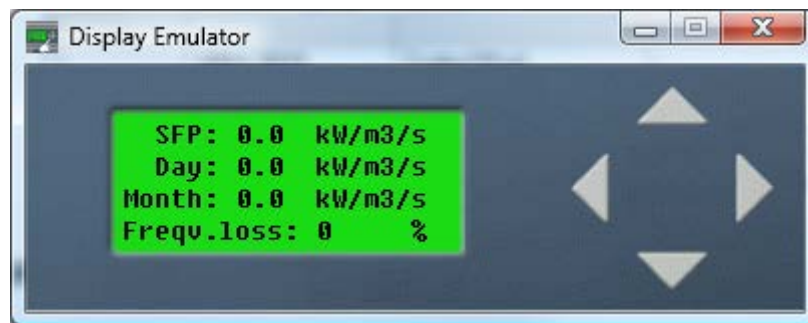

Index

A

- Access rights, 57
- Actuator type, 90
- Address, 104
- Air control, 65
- Alarm
 - Setting, 94
- Alarm events, 60
- Alarm forwarding, 100
- Alarm list, 94
- Alarm settings, 77
- Alarms, 51
 - Alarm delay at startup, 101
 - Alarm delays, 78
 - Alarm handling, 108
 - Alarm limits, 77
 - Alarm list, 94
- Analogue inputs, 15
- Analogue outputs, 15
- Automatic restart at power-up, 103

B

- Battery exchanger. See Liquid connected exchanger
- Blocking of automatic restart at power-up, 53
- Blocking of high speed, 100
- Buttons, 55

C

- Cascaded extract air temperature control, 31
- Cascaded room temperature control, 31
- Change language, 103, 109
- Change password, 58
- Change-over, 41
- Changing the battery, 109
- Close-off dampers, 50
- Communication, 98
- Configuration, 80
 - Actuator type, 90
 - Alarm setting, 94
 - Battery type, 84
 - Control function, 82
 - Cooling control, 85
 - Demand control, 88
 - Exchanger de-icing, 89
 - External setpoint, 89
 - Fan control, 83
 - Fire dampers, 88
 - Free cooling, 87
 - Heat exchangers, 85
 - Heater type, 84

- Humidity control, 89
- In- and outputs, 80
- Objects, 83
- Other parameters, 100
- Pump control, 86
- Run indication / Motor protection, 90
- Running time, 3-position actuators, 91
- Step controllers, 91
- Support control, 87
- System, 103
- Control function, 82
- Control pressure
 - Settings, 76
- Control signal, analogue outputs. See
- Cooling recovery, 39, 89
- Crosswise interlock, 84

D

- Damper control, 50
- Damper limit, 89
- De-icing Liquid connected exchanger. See Heat exchangers Liquid connected exchanger
- De-icing plate exchanger. See Heat exchangers Plate exchanger
- Demand control
 - Setpoint, 67
- Demand controlled ventilation, 47, 88
 - Mixing dampers, 35
- Dial-up modem, 99
- Digital inputs, 15
- Digital outputs, 15
- Display, 55
- DX cooling, 36, 91
 - Min limit lowering, 85
 - Setting, 91
- DX cooling, blocking, 86

E

- ELA, 104
- Electric heating, 33
- Energy calculation, 112
- Enthalpy control, 40, 89
- Exchanger de-icing, 34, 35, 89
 - Setpoint, 63
- Expansion model, 106
- Expansion unit and Modbus master, 99
- Extended running, 70
- External setpoint, 41, 89
- Extra control circuit, 42

- Extra flow sensors supply air and extract air, 42
- Extra sequence Y4, 84
- Extra sequence Y5, 84
- Extra temperature sensor, 42

F

- Fans
 - Control, 43
 - Delays, 100
 - Frequency control external control signal, 46
 - Frequency control flow, 45
 - Frequency control SAF with EAF slave, 46
 - Frequency control SAF with flow control EAF, 46, 47
 - Interlock, 84
 - Manual frequency control, 46
 - Pressure control, 44
 - Retardation time, 100
 - Timer output ½ speed, 70
 - Timer output 1/1 speed, 69
- Fire dampers, 50, 88
 - Exercising, 50
- Flow control
 - Extra compensation curve, 45
 - Outdoor compensation, 45
 - Setpoint, 45
 - Settings, 76
- Free cooling, 39, 87
- Free text, 108
- Frost protection, 32

H

- Hardware overview, 11
- Heat exchanger
 - Mixing dampers, 35
- Heat exchanger efficiency monitoring, 40, 64
- Heat exchangers, 34
 - Liquid connected exchanger, 35
 - De-icing, 35
 - Outdoor temp control of exchangers, 35
 - Plate exchanger, 34
 - De-icing, 34
 - Rotating exchanger, 35
 - Start condition, 101
- Holidays, 71
- Hot start, 100
- Humidity control, 42, 68, 89
 - Setpoint, 68
 - Settings, 77

I

- In-/Outputs, 60
- Indication LEDs, 109
- Information screen, 108
- Inputs and outputs, 15, 80
 - Analogue inputs, 15
 - Analogue outputs, 15

- Digital inputs, 15
- Digital outputs, 15
- Input and output lists, 17
- Universal inputs, 15
- Intermittent drift, 87

L

- Language, change, 103, 109
- LEDs, 55, 109
- Liquid connected exchanger, 35
- Log off, 57
- Log on, 57
- Logoff, 105

M

- Manual / Auto, 72
- Menus, 55
- Mixing dampers, 35
- Modbus, 98
- Model overview, 11
- Motor protection / Run indication, 90

N

- Navigating the menus, 55

O

- Objects, 83
- Other functions, 108
- Other parameters, 100
- Outdoor temp control of exchanger, 35
- Outdoor temp. for control mode change, 102
- Outdoor temperature compensated supply air control, 31
- Outdoor temperature dependent switching between supply air temperature control and extract air temperature control, 31
- Outdoor temperature dependent switching between supply air temperature control and room temperature control, 31
- Outputs. *See*
- Override of reduced speed for DX cooling, 86

P

- Password, 58
- PLA, 104
- Plate exchanger, 34
- Port 2, function, 98
- Pressure control, 44
 - Extra compensation curve, 44
 - Outdoor compensation, 44
 - Setpoint, 44
- Pretreatment, 93
- Pump control, 49, 86

R

- Recirculation, 41, 93
- Remote control, 105
- Restore alarm, 79
- Revision number, 108
- Rotating exchanger, 35
- Run indication / Motor protection, 90
- Running mode, 59
- Running mode, unit, 59
- Running time, 3-position actuators, 91

S

- Save and restore settings, 79
- Selected functions, 59
- Setpoint fan control, 65
- Setpoint humidity control, 68
- Setpoint, external, 41, 89
- Setpoints temperature, 61
- Settings, 75
- Shutdown mode, 33
- SMS, 100
- Specific Fan Power, 112
- Split of optional temp. sequence, 102
- Split settings, 101
- Start menu, 103
- Starting and stopping the unit, 53
- Start-up wizard, 105, 110
- Status indication, 109
- Step controllers, 36, 91
 - Setting, 91

- Summer time, 104
- Supply air control, 30
- Support control, 38, 87
 - Cooling, 38
 - Heating, 38

T

- Temperature, 61
- Temperature control, 29
 - Settings, 75
- Time settings, 69
- Time/Date, 69
- Timer output ½ speed, 70
- Timer output 1/1 speed, 69
- Timer outputs, 70
- Time-switch outputs, 51
- Types of chillers, 36

U

- Universal inputs, 15

V,W

- Vacon/Lenze/Omron/Emerson/LS/EBM frequency converters, 106
- Water heating, 32
- Wizard, 105, 110

Appendix

Appendix Frequency converters

When communicating via frequency converters through Modbus, it is sometimes necessary to change certain settings in the frequency converter. Below are described what settings are necessary in the various models:

Vacon NXL

No settings necessary.

Lenze

No settings necessary.

Omron V1000

Connected via RS485:

- R+ is connected to S+
- R- is connected to S-
- R+/S+ is connected to B on port 2
- R-/S- is connected to A on port 2

Parameters

The following parameters must be set from the display of the frequency converter:

- H5-01 (0x425): Slave address, set to = 1 for Supply air fan and = 2 for Exhaust air fan
- H5-07 (0x42B): RTS Control, set to = 1 (enabled) for activation of RS485
- o1-03 (0x502): Frequency reference units, set to = 1 for 0-100%.
- H5-03 (0x427): Parity, set to = 0 (no parity)

Default values should be used for remaining parameters. The following values may not be changed:

- H5-02 (0x426): Communication speed, default =3 (9600)
- H5-04 (0x428): Stopping method after communication error, default = 3 (no stop)
- H5-11 (0x43C): Communication Enter Function, default=1 (Enter command not necessary)
- H5-12 (0x43D): Run command, default=0 (bit 0=forward start/stop, bit 1= reverse start/stop)
- b1-01 (0x180): Frequency Reference selection 1, default = 2 (via Modbus)
- b2-01 (0x181): Run command selection 1, default = 2 (via Modbus)

Emerson Commander

Connections RS485-RJ45:

- RJ45:2 (orange) is connected to B on port 2
- RJ45:7 (white/brown) is connected to A on port 2
- Eventual termination resistor is connected between RJ45:1 (white/orange) and RJ45:8 (brown).

If Modbus communication is not initialised after powering up, disconnect the termination resistor and try again.

Terminals

- Connect terminal B4 (Drive enabled) to B2 (+24V)
- Connect terminal B5 (Forward) to B2 (+24V)

Parameters

The following parameters must be set from the display of the frequency converter:

- 44: Slave address, set to = 1 (default) for Supply air fan and = 2 for Exhaust air fan
- 43: Baud rate: 9.6 (default: 19.2)
- Default values should be used for remaining parameters.

Changing parameters

- Deactivate the unit. The display should read “iH 0.0”. This is performed by opening terminal B4.
- Set parameter 10 to ”L3”, i.e. all parameters up to and including 95 can then be altered.
- Set parameter 43 to 9.6 (9600 baud).

LS

LS frequency converters are controlled via Modbus. Communication, alarms and certain indications can be read:

Address	Modbus register	Name	Scaling	Type
27	30027,40027	FB Status word	-	Binary
511	30511,40511	Cumulative output	0.1	kWh
527	30527,40527	Motor frequency	0.1	+/- Hz
508	30508,40508	Motor current	0.1	A
510	30510,40510	Motor output	0.01	kW
505	30505,40505	DC voltage	1	V
30	30030,40030	Active error	-	Error code

The following parameters are used to control fan speed:

Address	Modbus register	Name	Scaling	Type
1	30001,30001	FB Status word	-	Binary
44	30044,40044	FB Setpoint speed	0.1	Hz
48	30048,40048	Password	-	Binary
49	30049,40049	Password	-	Binary

EBM

EBM frequency converters are controlled via Modbus. Communication, alarms and certain indications can be read.

The following signals can be read from the frequency converter:

Address	Modbus register	Name	Scaling	Type
27	30027,40027	FB Status word	-	Binary
511	30511,40511	Cumulative output	0.1	kWh
527	30527,40527	Motor frequency	0.1	+/- Hz
508	30508,40508	Motor current	0.1	A
510	30510,40510	Motor output	0.01	kW
505	30505,40505	DC voltage	1	V
30	30030,40030	Active error	-	Error code

The following signals can be used to control fan speed:

Address	Modbus register	Name	Scaling	Type
1	30001,30001	Control Word	-	Binary
44	30044,40044	FB Setpoint speed	0.1	Hz
48	30048,40048	Password	-	Binary
49	30049,40049	Password	-	Binary

REGIN - THE CHALLENGER IN BUILDING AUTOMATION

AB Regin

Head office

Box 116, S-428 22 Källered,
Sweden

Phone: +46 31 720 02 00

Fax: +46 31 720 02 50

info@regin.se

www.regincontrols.com



THE CHALLENGER IN BUILDING AUTOMATION